



Alfa *GT*

OWNER'S MANUAL



Dear Client,

Thank you for choosing Alfa Romeo.

*Your **Alfa GT** has been designed to guarantee the safety, comfort and driving pleasure typical of Alfa Romeo.*

This booklet will help you to get to know the characteristics and operation of your car.

*The following pages contain all the indications necessary for you to be able to maintain the high standards of performance, quality, safety and respect for the environment which characterise this **Alfa GT**.*

The enclosed Warranty Booklet also contains the regulations, the warranty certificate and a guide to the services offered by Alfa Romeo.

Services which are essential and precious because, when you purchase an Alfa Romeo, you are not only acquiring a car, but the tranquillity that comes from knowing that an efficient, willing and widespread organisation is at your service for any assistance problems you may have.

Nature benefits in two ways: there's no pollution from waste disposal and the demand for raw materials is reduced.

Enjoy the reading. And have a good trip.

This booklet describes all the versions of the Alfa GT, so you should only consider the information concerning the trim level, engine and version purchased by you.

VERY IMPORTANT!

FUEL CAPACITY



Petrol engines: only use unleaded petrol with no less than 95 R.O.N.



Diesel engines: only refuel with diesel fuel conforming to the European specification EN590. The use of other products or mixtures may irreparably damage the engine with invalidation of the warranty due to the damage caused.

STARTING THE ENGINE



Petrol engines with mechanical transmission: make sure that the handbrake is engaged; set the gearshift lever to neutral, fully depress the clutch without pressing the accelerator, then turn the ignition key to **AVV** and release it as soon as the engine has started.

Petrol engine with Selespeed transmission: keep the brake pedal fully depressed, turn the ignition key to **AVV** and release it as soon as the engine has started; the transmission sets to neutral automatically (the display shows position **N**).

JTD engines: turn the ignition key to **MAR** and wait for the  and  warning lights to go off; turn the ignition key to **AVV** and release it as soon as the engine has started.

PARKING ON FLAMMABLE MATERIAL



While working, the catalyst develops a very high temperature. Do not park the car over grass, dry leaves, pine needles or any other inflammable materials: risk of fire.

RESPECTING THE ENVIRONMENT



The car is fitted with a system that allows continuous diagnosis of the components correlated with emissions to ensure better respect for the environment.

ACCESSORY ELECTRICAL DEVICES



If after purchasing the car you wish to install accessories that need an electrical supply (with the risk of gradually draining the battery), contact Alfa Romeo Authorised Services who will assess the overall electrical absorption and check whether the car system is able to withstand the load required.

CODE CARD (for versions/markets where applicable)



Keep it in a safe place, not in the car. IT is advisable to always keep the electronic code on the CODE card with you in case emergency starting is necessary.

SCHEDULED SERVICING



Correct maintenance makes it possible to preserve car performance levels and safety, respect for the environment and low running costs unaltered over the course of time.

THE OWNER HANDBOOK...



... you will find important information, advice and warnings for correct use, driving safety and car maintenance over time. Pay particular attention to the symbols  (personal safety)  (protecting the environment)  (car safety).

Any queries concerning servicing should be forwarded to the showroom from which the car was purchased, the subsidiary company or to our branch offices or any point of the Alfa Romeo Network.

Warranty Booklet

The Warranty Booklet is delivered together with every new car and contains the regulations tied to the services given by Alfa Romeo Services and to the warranty conditions.

Correctly carrying out the scheduled services specified by the manufacturer is the best way to maintain the performance, safety characteristics and low running costs of your car. It is also necessary to maintain warranty cover.

“Service” guide

This contains Alfa Romeo Authorised Services. The Services can be recognised by the presence of the Alfa Romeo badge and logo.

The Alfa Romeo organisation in Italy can be found in the telephone directory under the letter “A” Alfa Romeo.

Not all of the models described in this booklet are available in all countries. Only some of the fittings described in this booklet are fitted as standard to the car. The list of available accessories should be requested from the Alfa Romeo Dealers.

THE SYMBOLS USED IN THIS BOOKLET

The symbols illustrated in these pages show the subjects which should, in particular, be closely studied.



PERSONAL SAFETY

Warning. Partially or fully ignoring these rules may lead to serious injury.



PROTECTING THE ENVIRONMENT

This indicates the correct procedures to be followed to prevent the car from damaging the environment.



CAR SAFETY

Warning. Partially or fully ignoring these rules may lead to serious damage being caused to the car which, in some circumstances, may cause forfeiture of the warranty cover.

*The texts, illustrations and specifications given in this booklet refer to the car at the time of going to press.
As part of our ongoing striving to improve our products, Alfa Romeo may introduce technical changes during production, therefore the specifications and fittings may be altered without prior notice.
For details on this subject, please apply to the manufacturer's sales network.*

GETTING TO KNOW YOUR CAR

SYMBOLS

On some of the components making up your **Alfa GT**, or near to them, special coloured labels have been attached. These labels bear symbols that remind you of the precautions to be taken as regards that particular component. A summary list of the symbols (**fig. 1**) is to be found under the bonnet.

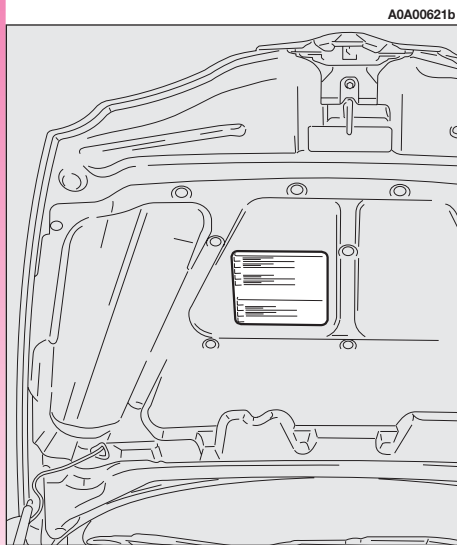

fig. 1

THE ALFA ROMEO CODE SYSTEM

To increase protection against attempted theft, the car is fitted with an electronic engine lock system (Alfa Romeo CODE) which is activated automatically when the key is removed from the ignition. In fact the grip of each key contains an electronic device which modulates the radio frequency signal transmitted when the engine is started by a special aerial incorporated in the ignition switch. This modulated signal is the "password" by which the control unit recognises the key and only in this condition can the engine be started.

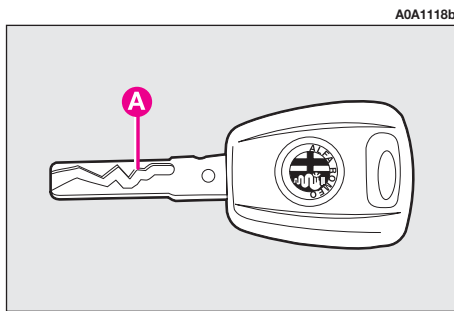

fig. 2

KEYS

The car is delivered with a key with metal insert (upon request for models/markets where required) and a key with remote control. For models/markets where required two keys with remote control can be provided.

KEY WITHOUT REMOTE CONTROL (for versions/markets where applicable)

The fixed metallic insert **A-fig. 2** operates:

- the ignition switch;
- the driver's door lock;
- the passenger's Air bag deactivation (upon request for versions/markets where applicable);
- the fuel filler cap lock.

IMPORTANT To guarantee the perfect efficiency of the electronic devices contained in keys, avoid letting them directly exposed to sunrays.

Together with the keys the CODE card is provided (for versions/ markets where applicable) (fig. 3), bearing in print the key codes (both mechanical and electronic for emergency start up).

The code numbers on the CODE card must be kept in a safe place , not in the car.

The driver should always keep the electronic CODE card with him/her in the event of having to carry out emergency starting.



If the car changes owner, the new owner must be given all the keys and the CODE card.

KEY WITH REMOTE CONTROL

The key with remote control (fig. 4) is fitted with:

- a metal insert (A) that can be enclosed in the key grip
- a button (B) for power-assisted opening of the metal insert
- a button (C) for remote door unlocking and at the same time switching off the electronic alarm
- a button (D) for remote door locking and at the same time switching on the electronic alarm
- a button (E) for remote boot unlocking
- removable hook ring (F).

A0A0003b

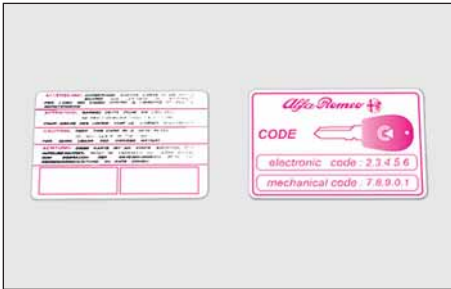

fig. 3

A0A0600b

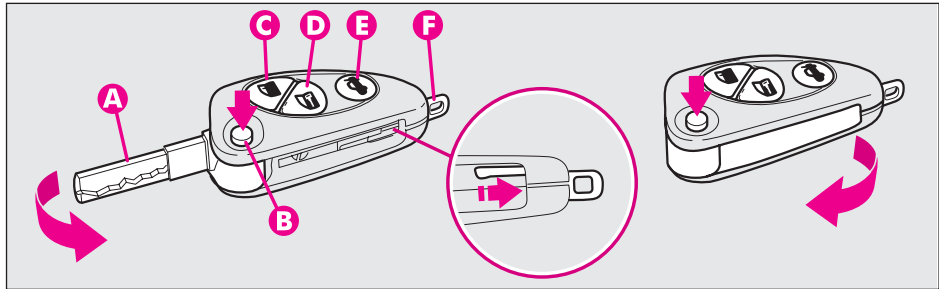



fig. 4

- The metal insert (**A**) of the key operates:
- the ignition switch
 - driver's door lock and, upon request for versions/markets where applicable, the passenger's door lock
 - the passenger's side Air bag deactivation switch
- To bring the metal insert out of the key grip, press the button (**B**).
- To pull out the hook ring (**F**) use a finely pointed object (e.g. pen) and work in the direction of the arrow.
-  **The button B should only be pressed when the key is away from the body, in particular from the eyes, and from objects that can be spoilt (clothes for instance). Make sure the key can never be touched by others, especially children, who may inadvertently press the button.**

- To insert the metal insert in the key grip:
- keep the button (**B**) pressed
 - move the metal insert (**A**)
 - release the button (**B**) and turn the metal insert (**A**) until hearing the click as it locks into place.

To unlock the doors by remote control press button (**C**), the doors unlock and the direction indicators flash twice. To lock the doors by remote control, press button (**D**), the doors lock and the direction indicators flash once. Pressing button (**C**) the doors are released, if within the next 60 seconds a door or the tailgate are not opened, the system automatically locks everything again.

On cars fitted with electronic alarm system, pressing button (**C**) turns it off, pressing button (**D**) turns it on.

OPENING THE TAILGATE

The tailgate can be opened from outside by remote control pressing button (**E**), even if the electronic alarm is on. Opening of the tailgate is accompanied by the direction indicators flashing twice; closing is accompanied by a single flash.

If the electronic alarm is fitted, when the tailgate is opened the alarm system switches off volumetric protection and the tailgate control sensor, the system (with the exception of versions for certain markets) “beeps” twice.

Closing the tailgate again, the control functions are restored, the system “beeps” twice (with the exception of certain markets).

OPERATION

Each time the ignition key is turned to the **STOP** position the Alfa Romeo CODE system deactivates the functions of the engine electronic control unit.

Each time the car is started turning the ignition key to **MAR**, the Alfa Romeo CODE control unit sends a recognition code to the engine control unit to deactivate the inhibitor. The code is crypted and variable between over four billion possible combinations, and it is sent only if the system control unit has recognised the code transmitted from the key which contains an electronic transmitter, through an aerial wound around the ignition switch.

If the code has not been recognised correctly, the Alfa Romeo CODE warning light (🚗) on the cluster turns on.

In this case, the key should be moved to the **STOP** position and then back to **MAR**; if the lock continues, possibly try again with the other key provided with the car. If it is still not possible to start the car, follow the instructions given in the "In an emergency" chapter and then contact Alfa Romeo Authorised Services.

IMPORTANT Every key has its own code, which must be memorised by the system control unit. To memorise new keys, up to a maximum of eight, apply solely to Alfa Romeo Authorised Services taking with you all the keys in your possession, the CODE card, a personal identity document and the car's ownership documents.



The codes of any keys not presented during the memorising procedure are erased. The reason for this is to ensure that any lost or stolen keys cannot be used to start the engine.

IMPORTANT Turning on of the Alfa Romeo CODE warning light (🚗) when travelling with the ignition key at **MAR**:

1) If the warning light turns on, this means that the system is running a self-test (for example for a voltage drop). At the first stop, it will be possible to test the system: switch off the engine turning the ignition key to **STOP**; then turn the ignition key to **MAR**: the warning light turns on and should go off in about one second. If the warning light stays on, repeat the procedure described previously leaving the key at **STOP** for over 30 seconds. Should the inconvenience persists, contact Alfa Romeo Authorised Services.

2) For versions without the reconfigurable multifunction display, the flashing of the warning light means that the car is not protected by the engine inhibitor device. This condition for cars with reconfigurable multifunction display is shown by the turning on of the warning light together with the display of the message: "CODE SYSTEM NOT PROGRAMMED". Contact Alfa Romeo Authorised Services immediately to have all the keys memorised.



If after about 2 seconds with the ignition key at MAR, for versions without reconfigurable multifunction display, the Alfa Romeo CODE warning light (🚗) turns on again flashing, or for versions with reconfigurable multifunction display, the warning light turns on again together with the message “CODE SYSTEM NOT PROGRAMMED”, this means that the code of the keys has not been stored, therefore the car is not protected by the Alfa Romeo CODE system against attempted theft. In this case contact Alfa Romeo Authorised Services to have the key codes stored.

KEY BATTERY REPLACEMENT

If when pressing button (B or C-fig. 6) on the remote control, nothing happens, the battery should be replaced by a new one of the same type to be found c/o normal retailers.



Used batteries are harmful to the environment. They should be disposed of as specified by law in the special containers provided. Avoid exposure to naked flames and high temperatures. Keep out of reach of children.

Battery replacement:

- press button (A-fig. 5) and move the metal insert (B) to the open position;
- using a finely-tipped screwdriver, turn the opening device (C) and pull out the battery holder (D);
- replace the battery (E) making sure that the bias is correct;
- re-insert the battery holder in the key and lock it, turning the device (C).

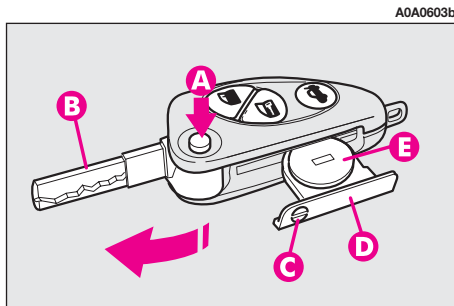

fig. 5

ELECTRONIC ALARM

DESCRIPTION

The system comprises: a transmitter, receiver, control unit with siren and volumetric sensors. The electronic alarm is controlled by the receiver incorporated in the instrument cluster and it is turned on and off by the remote control in the key which sends the crypted and variable code. The electronic alarm controls: the unlawful opening of doors, bonnet and boot (perimetral protection), operation of the ignition key, battery cable cutting, the presence of moving bodies in the passenger compartment (volumetric protection), any abnormal raising/sloping of the car (for versions/markets where applicable) and central door locking. It also makes it possible to cut off the volumetric protection.

IMPORTANT The engine inhibitor function is guaranteed by the Alfa Romeo CODE system which is activated automatically when the ignition key is removed.

The remote control is incorporated in the key and it is fitted with buttons (**B-C-D-fig. 6**) that activate the corresponding control sending the code to the receiver. This code (rolling code) changes at each transmission.

REQUEST FOR ADDITIONAL KEYS WITH REMOTE CONTROL

The receiver can recognise up to 5 keys with incorporated remote control. Should a new key with remote control be necessary for any reason during the life of the car, contact directly Alfa Romeo Authorised Services, taking with you the CODE card, a personal identity document and the car's ownership documents.

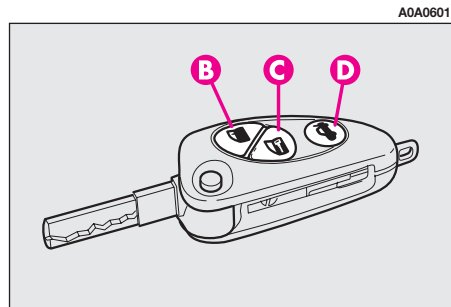

fig. 6

HOW TO ACTIVATE THE ALARM

With the doors, bonnet and boot shut and the ignition key in the **STOP** or **PARK** position (key removed), point the key with the remote control in the direction of the car, then press and release the button (**C-fig. 6**).

With the exception of certain markets, the system sounds a "beep" and the doors are locked.

Engagement of the alarm is preceded by a self-diagnostic test indicated by a different flashing frequency of the deterrent led (**A-fig. 7**) on the dashboard. If a fault is detected the system sounds a further warning "beep".

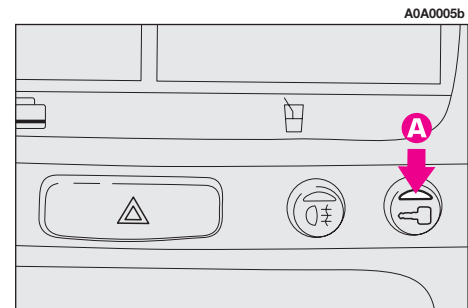

fig. 7

Surveillance

After switching on, the flashing of the deterrent led (**A-fig. 7**) on the dashboard indicates the system surveillance mode. The led flashes throughout this period.

IMPORTANT Operation of the electronic alarm is adapted at the origin to the rules of the different countries.

Self-diagnostic functions and door, bonnet, boot control

If, after engaging the alarm, a second “beep” is sounded, switch off the system pressing the button (**B-fig. 6**), check that the doors, bonnet and tailgate are properly shut, then switch the system on again pressing the button (**C**). Otherwise, the door, bonnet or tailgate that is not shut properly will be excluded from the alarm system control.

If the doors, bonnet and boot are shut correctly and the control signal is repeated, the system self-diagnostic has detected a system operating fault. It is therefore necessary to contact Alfa Romeo Authorised Services.

HOW TO DEACTIVATE THE ALARM

To deactivate the alarm press the button (**B-fig. 6**) of the key with remote control. The system will react as follows (with the exception of certain markets):

- two brief flashes of the direction indicators
- two brief “beeps” of the system
- door unlocking.

IMPORTANT If when the system is turned off the deterrent led (**A-fig. 7**) on the dashboard stays on (maximum 2 minutes or until the ignition key is set to **MAR**) the following should be borne in mind:

– if the led continues flashing, but at different intervals than normal, this means that different attempts to break in have occurred. Through the number of flashes it is possible to identify the type of attempt:

- 1 flash:** one or more doors
- 2 flashes:** tailgate
- 3 flashes:** bonnet
- 4 flashes:** ultrasounds
- 5 flashes:** abnormal car lifting/sloping (for versions/markets where applicable)
- 6 flashes:** tampering with car starting cables
- 7 flashes:** tampering with battery cables or cutting emergency key cables
- 8 flashes:** connection line to sensors and siren
- 9 flashes:** at least three causes of alarm.

WHEN THE ALARM IS TRIGGERED

When the system is on, the alarm comes into action in the following cases:

- opening of one of the doors, bonnet or tailgate;
- disconnection of the battery or sectioning of electric cables;
- intrusion in the passenger compartment, for example breakage of windows (volumetric protection);
- attempt to start the engine (key in **MAR** position);
- abnormal car lifting/sloping (for versions/markets where applicable).

Depending on the markets, the cutting in of the alarm causes operation of the siren and hazard warning lights (for about 26 seconds). The ways of operating and the number of cycles may vary depending on the markets.

A maximum number of cycles is however envisaged.

Once the alarm cycle has ended, the system resumes its normal control function.

VOLUMETRIC PROTECTION

To make sure that the protection system works correctly the side windows and sunroof (if fitted) must be properly shut.

The function can be cut off (if, for example, leaving animals in the car) carrying out the following operations in rapid succession: starting from the condition with the ignition key at **MAR**, move the key to **STOP**, then immediately back to **MAR** and then to **STOP** again, then remove the ignition key.

The deterrent led (**A-fig. 7**) on the dashboard lights up for about 2 seconds to confirm that the function has been cut off.

To restore volumetric protection, move the and keep the ignition key at **MAR** for over 30 seconds.

If, with the volumetric protection function deactivated, an electric control controlled by the ignition key at **MAR** (e.g. power windows) turn the ignition key to **MAR**, operate the control and move the key to **STOP** in a maximum time of 30 seconds. This way volumetric protection is not restored.

HOW TO CUT OFF THE ALARM SYSTEM

To deactivate the alarm system completely (for instance during prolonged inactivity of the car) simply lock the car turning the key in the lock.

MINISTERIAL CERTIFICATION

In accordance with the law in force in each country, on the subject of radio frequency, we wish to point out that for the markets in which the transmitter needs to be marked, the certification number is given on the component.

Depending on the versions/markets, the code may also be given on the transmitter and/or on the receiver.

IGNITION DEVICE

SWITCH (fig. 8)

The key can be turned to one of four positions:

– **STOP**: engine switched off, key can be removed, engine inhibitor engaged, steering lock engaged, services excluded apart from those supplied directly (e.g. hazard warning lights).

– **MAR**: drive position. The engine lock is deactivated and all electrical devices are powered.

IMPORTANT Do not leave the key in this position when the engine is stopped.

– **AVV**: unstable position for starting the engine.

IMPORTANT If the engine fails to start move the key back to **STOP** and repeat.

The ignition switch has a safety device which prevents passage to **AVV** when the engine is running.

– **PARK**: engine switched off, key can be removed, engine lock engaged, steering lock engaged, sidelights switched on automatically.

IMPORTANT To turn the key to the **PARK** position, button **(A)** on the switch must be pressed first.



When leaving the car always remove the key from the ignition to prevent any occupants of the car from accidentally activating the controls. Never leave children in the car unaccompanied. Remember to engage the handbrake and, if the car is parked on an uphill slope, to engage the first gear. If the car is facing downhill, engage reverse gear.



If the ignition device is tampered with (for example an attempted theft) have it checked over by Alfa Romeo Authorised Services before travelling again.

A0A0016b

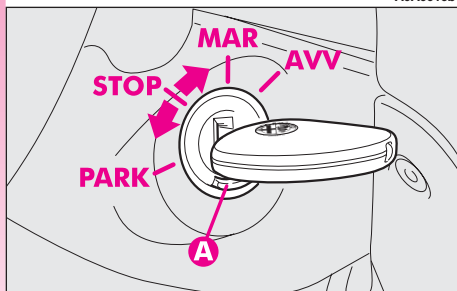

fig. 8

STEERING LOCK

Engaging:

— move the key to **STOP** or **PARK**, then remove the key and turn the steering wheel slightly to facilitate the locking action.

Disengaging:

— turn the key to **MAR** gently rocking the steering wheel from side to side.



Never remove the ignition key with the car on the move. The steering wheel would lock automatically the first time the steering wheel is turned. This also occurs if the car is towed.



It is absolutely forbidden to carry out whatever after-market operation involving steering system or steering column modifications (e.g.: installation of anti-theft device) that could badly affect performance and safety, cause the lapse of warranty and also result in non-compliance of the car with homologation requirements.

DOORS



Before opening a door, always make sure that it can be done safely.

OPENING/CLOSING FROM OUTSIDE

Front doors

— To open the door, turn the key (clockwise for the driver's door and, upon request for versions/markets where applicable, counterclockwise for the passenger's door), then remove the key and pull the lever (**A-fig. 9**).

— To close the door, turn the key in the lock in the opposite direction to the one for opening.

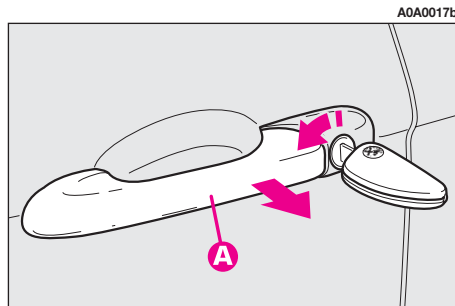

fig. 9

OPENING/CLOSING FROM INSIDE

Front doors

— To open the door, pull the handle (**A-fig. 10**).

— To close the door, pull it; then to prevent opening from the outside, press the button (**A-fig. 11**) on the dashboard, the deterrent led (**B**) on the button lights up with a yellow light to confirm that locking has taken place.

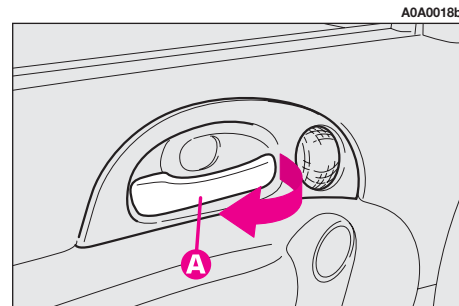

fig. 10

CENTRAL LOCKING

This allows central locking of the door locks.

To engage central locking, the doors must be perfectly shut, otherwise locking is denied.

IMPORTANT With central locking engaged, pulling the inside lever for opening one of the front doors causes the unlocking of all the doors.

In the event of a power cut off (blown fuse, battery disconnected, etc.) it is still possible to work the lock by hand.

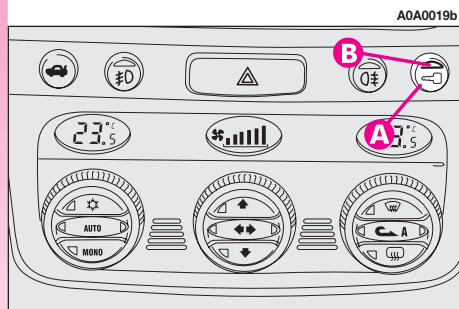

fig. 11

FRONT SEATS



Only make adjustments when the car is stationary.

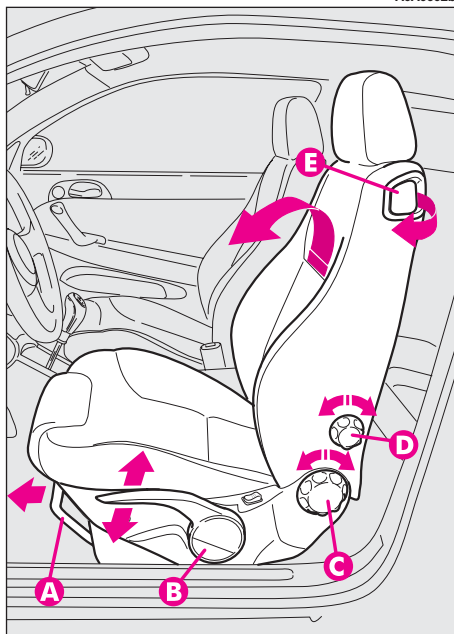

fig. 12



Fabric upholstery of your car is purpose-made to withstand common wear resulting from normal use of the car. It is however absolutely necessary to prevent hard and/or prolonged scratching/scraping caused by clothing accessories like metallic buckles, studs, "Velcro" fixings, etc. that stressing locally the fabric could break yarns and damage the upholstery as a consequence.

LENGTHWISE ADJUSTMENT (fig. 12)

Raise the lever (A) and push the seat backwards or forwards; in the driving position the arms should be slightly flexed and the hands should rest on the rim of the steering wheel.



After releasing the adjustment lever, always check that the seat is locked on the runners, trying to move it to and fro. The lack of this clamping action could cause the seat to move unexpectedly and cause loss of car control.

DRIVER'S SEAT LUMBAR ADJUSTMENT (fig. 12)

Turn the knob **(D)** until obtaining the most comfortable position.

DRIVER'S SEAT HEIGHT ADJUSTMENT (fig. 12)

To raise the seat, pull the lever **(B)** upwards, then work the lever (up and down) until reaching the required height, then release it. To lower the seat, push the lever **(B)** downwards, then work the lever (up and down) until reaching the required height.

IMPORTANT Adjustment must be carried out only seated in the driver's seat.

TILTING THE BACK REST (fig. 12)

To gain access to the rear seats, pull the handle **(E)**, the back rest folds and the seat is free to run forwards.

A recovery mechanism with memory makes it possible to take the seat back to its previous position.

Once the seat back has been returned to the travelling condition, make sure that it is correctly clamped, checking that the "red band" on the upper part of the handle **(E)** is concealed. In fact, this "red band" indicates that the seat back is not clamped.

Also check that the seat is firmly locked on the runners, trying to move it to and fro.

BACK REST ANGLE ADJUSTMENT (fig. 12)

Turn the knob **(C)** until reaching the position required.

CENTRAL ARMREST (fig. 13)

The armrest, fitted on some versions, is adjustable and can be raised and lowered to the required position.

To adjust, slightly raise the armrest, then press the the release device **(A)**.

Inside the armrest there is an oddments compartment, to use it, raise the cover, pressing the device **(B)**.

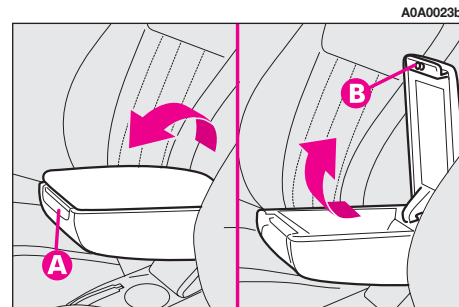

fig. 13

SEAT WARMING (fig. 14)

Seat warming, fitted on certain versions, is turned on and off through the switch (A) on the outer side of the seat.

Switching on is shown by the lighting up of the led (B) on the switch itself.

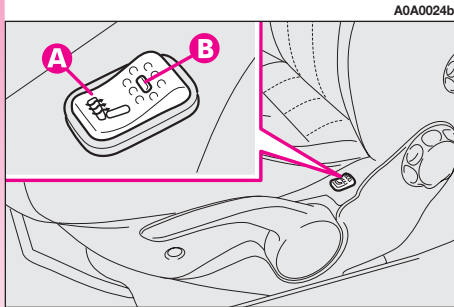

fig. 14

HEADREST ADJUSTMENT (fig. 15)

To increase passengers' safety, the headrests are adjustable in height.

To adjust, press the button (A) and move the headrest up or down until it clicks into place.

IMPORTANT The configuration of the headrest cushion may vary depending on the versions and markets. The purpose of the illustration is only to show how it is adjusted.

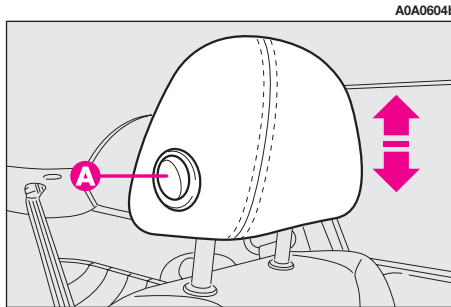

fig. 15



Remember that headrests should be adjusted so that the nape, and not the neck, rests on them. Only in this position do they exert their protective action in the event of a crash from behind.

REAR POCKETS (fig. 16) (for versions/markets where applicable)

The front seats are fitted with a pocket in the rear of the back rest.

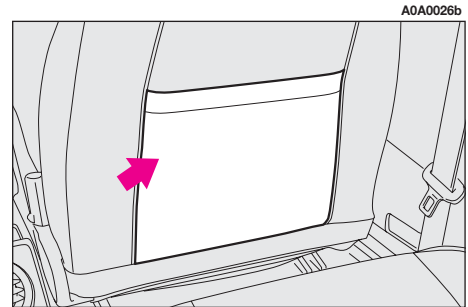

fig. 16

REAR SEATS



Fabric upholstery of your car is purpose-made to withstand common wear resulting from normal use of the car. It is however absolutely necessary to prevent hard and/or prolonged scratching/scraping caused by clothing accessories like metallic buckles, studs, "Velcro" fixings, etc. that stressing locally the fabric could break yarns and damage the upholstery as a consequence.

EXTENDING THE LUGGAGE COMPARTMENT

The split of rear seat makes it possible to extend the luggage compartment totally or partially, acting separately on one of the two parts, thereby offering different possibilities of load depending on the number of rear passengers.



If a particularly heavy load is placed in the boot, when travelling at night, it is wise to check the height of the high beams (see "Headlamps" paragraph).

Removing the rear parcel shelf

Proceed as follows:

- free the ends of the two rods (**A**-fig. 18) supporting the parcel shelf (**B**) pulling the eyelets (**C**) off the pins (**D**);
- release the pins (**A**-fig. 19) at the outside of the shelf from their housings (**B**) obtained in the side supports, then remove the shelf pulling it outwards.

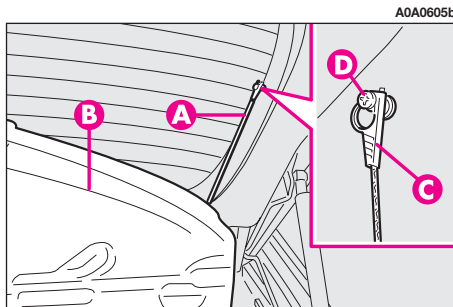

fig. 18

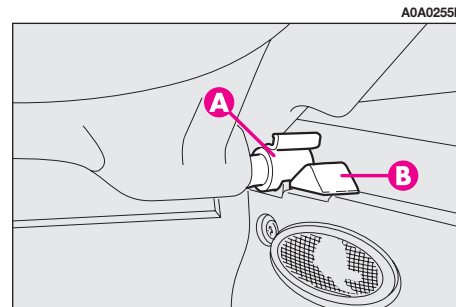

fig. 19

Total extension

Proceed as follows:

– check that seat buckles of the side belts are fitted in the respective pockets on the back rest (**A-fig. 20**) and the tab (**B**) of the centre abdominal belt is inserted in the support (**C**).

– pull the handles in the centre of the cushions, then tilt them forwards;

– raise the headrest to the highest position, press both buttons (**A-fig. 21**) at the side of the two supports, then remove the headrest pulling them upwards;

– move the seat belts to the side extending them correctly without twisting;

– raise the levers (**A-fig. 22**) retaining the back rests and tilt them forwards to obtain a single loading surface (**fig. 23**).

IMPORTANT For versions/markets where applicable, the retainer levers are replaced by buttons (one for each side). To release the back rests and tilt them, use the buttons themselves.

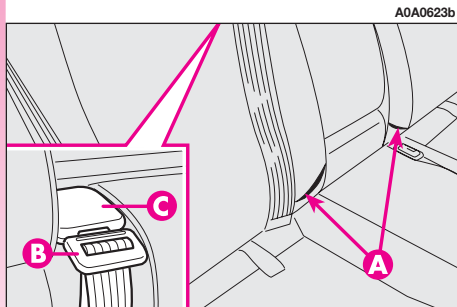

fig. 20

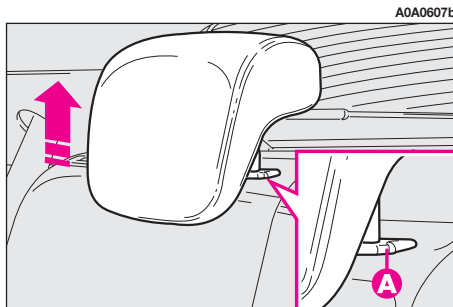

fig. 21

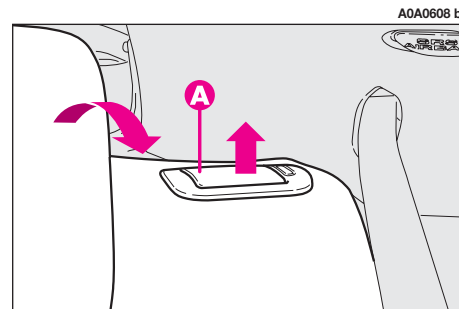

fig. 22

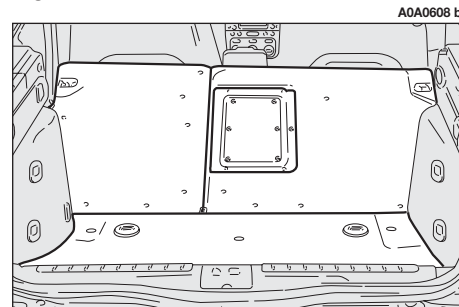

fig. 23

Partial extension

For partial extension, proceed as follows:

- tilt the cushion required pulling the handle at the centre of the cushion, then tilting the actual cushion;
- move the seat belt to one side extending it correctly without twisting;
- raise the lever retaining the back rest and tilt it forwards.

To bring the seat back to its normal position

Proceed as follows:

- move the seat belts to one side extending them correctly without twisting;
- raise the seat backs, pushing them backwards until hearing both clamping devices click into place;
- set the cushions to the horizontal position keeping the centre seat belt raised.

HEADREST ADJUSTMENT (fig. 24)

The car may be fitted with two headrests for the side seats and, depending on the trim level, it may also have a third headrest in the centre.

To use the headrest, raise it from the (2) “non use position” and reach the (1) “all removed” position. To restore the “non use position”, press button (A-fig. 21) and push the headrest downwards.

All rear headrests can be removed.

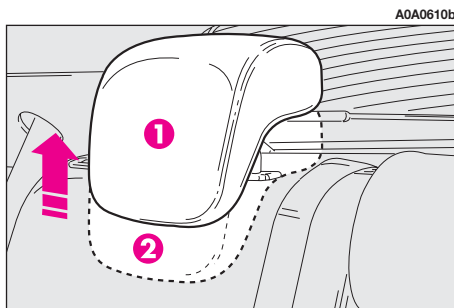



fig. 24

The particular headrest shape interferes intentionally with the rear passenger’s correct position on the back rest; this forces the passenger to raise the headrest to use it correctly.

IMPORTANT When using rear seats, the headrests shall be kept in the “all removed” position.

 Remember that headrests should be adjusted so that the nape, and not the neck, rests on them. Only in this position do they exert their protective action in the event of a crash from behind.

CENTRAL ARMREST (fig. 25)

To use the armrest (A), present only on certain versions, lower it as illustrated.

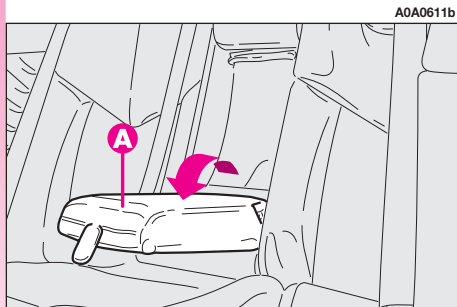

fig. 25

LUGGAGE RETAINER NET (where provided)

Present only on certain versions, the retainer net (fig. 26) is helpful in correctly arranging the load and/or suitable for transporting light materials.

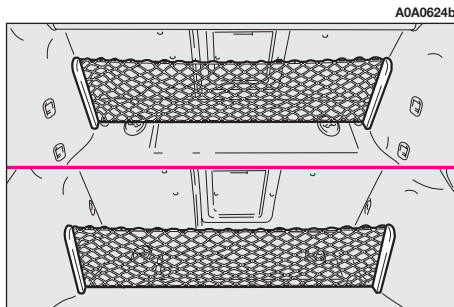



fig. 26

STEERING WHEEL

The driver can adjust the steering wheel position in rake and height.

To do this, release the lever (A-fig. 27) pulling it towards the steering wheel.

After moving the steering wheel to the most suitable position, lock it pushing the lever fully forwards.

 Any adjustment of the steering wheel position must be carried out only with the car stationary.

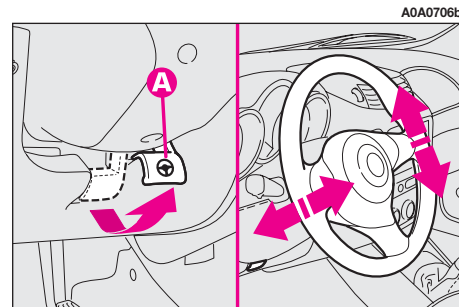

fig. 27

REAR-VIEW MIRROR ADJUSTMENT

INNER

The mirror, fitted with a safety device that causes it to be released in the event of a violent crash, can be moved using the lever (**A**-fig. 28) to two different positions, normal or antiglare.

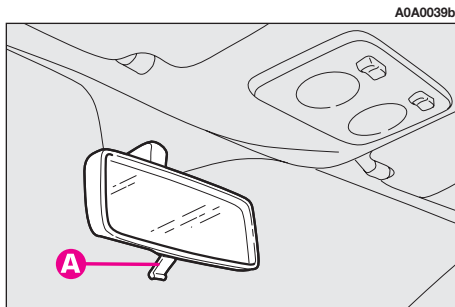

fig. 28

OUTER

Electric adjustment (fig. 29)

— use the switch (**A**) to select the mirror required (right or left);

— pressing the button (**B**) in one of the four directions, move the mirror selected previously;

— position the switch (**A**) in the intermediate locking position.

IMPORTANT Adjustment is possible only with the ignition key at **MAR**.

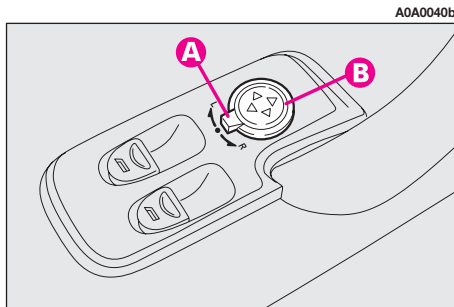

fig. 29

Folding (fig. 30)

— In the event of need (for example when the mirror causes difficulty in narrow spaces) it is possible to fold the mirror moving it from position (**A**) to position (**B**).



When driving the mirrors should always be in position (A).



As the driver's wing mirror is curved, it may slightly alter the perception of distance.

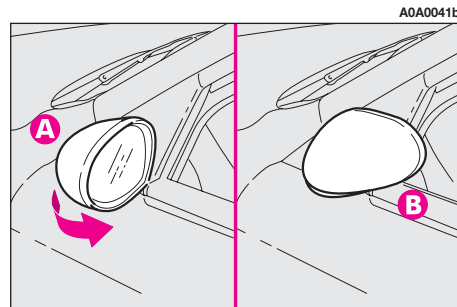

fig. 30

Defrosting/demisting (fig. 31-32)

The electric mirrors are fitted with heating coils which come into operation with rearscreen heating pressing the button **(A)** thereby defrosting and/or demisting the mirrors.

IMPORTANT The function is timed and automatically switched off after a few minutes.

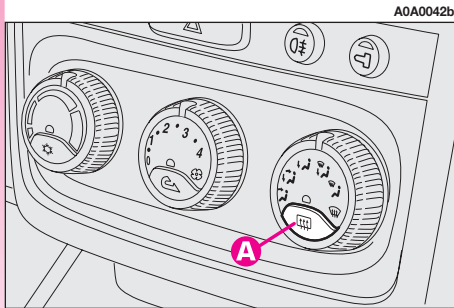

fig. 31

POWER WINDOWS

IMPORTANT With the ignition key at **STOP** or removed, the power windows remain activated for about 3 minutes and are deactivated immediately the moment a door is opened.

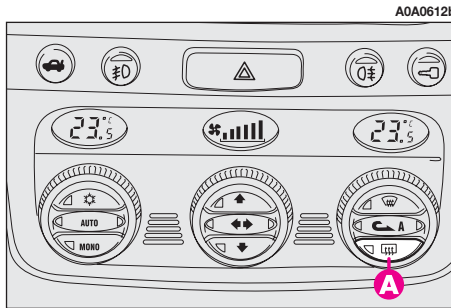

fig. 32

Driver' side (fig. 33)

The driver's door panel contains the buttons that control the following windows, with the ignition key at **MAR**:

- A** - left front window
- B** - right front window.

Press the button to lower the window. Pull to raise it.

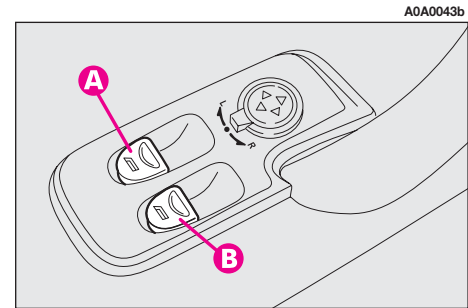

fig. 33

IMPORTANT The driver's power window is fitted with the "continuous automatic operation" device for both lowering and raising the window. A brief press on the upper or lower part of the button will cause it to move and continue automatically: the window stops in the required position by pressing either the upper or lower part of the button again. The passenger window is fitted with "automatic continuous operation" device just for window opening.

Passenger's side (fig. 34)

The button **(A)** controls the passenger's side window.

Button and window operation is the same as that described for driver's side.



Improper use of the power windows can be dangerous. Before and during its operation, always make sure that passengers are not exposed to the risk of harm either directly by the moving windows or by personal objects drawn or knocked by them.



Always remove the ignition key when getting out of the car to prevent the power windows being operated accidentally and constituting a danger to the passengers in the car.



Do not keep the button pressed when the window is completely raised or lowered.

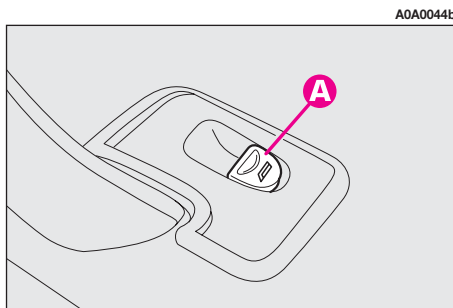

fig. 34

For all versions, after unlocking the doors, keeping the remote control button pressed for about 2 seconds will obtain window opening.

IMPORTANT For versions/markets where applicable, after turning off control unit power (replacing or disconnecting the battery or replacing the power window control unit protection fuses), window automatism shall be restored.

Proceed as follows with **doors closed**:

1. open completely the driver's window keeping the **button pressed** for at least 3 seconds after full opening;
2. close completely the driver's window keeping the **button pressed** for at least 3 seconds after full closing;
3. proceed as described in points 1 and 2 also for the passenger's side;
4. check for proper initialisation by operating the windows in automatic.

SEAT BELTS

USING THE SEAT BELTS

The belt should be worn keeping the chest straight and rested against the seat back.

To fasten the seat belts: hold the tongue (**A-fig. 35**) and insert it into the buckle (**B**), until hearing the locking click. At removal, if it jams, let it rewind for a short stretch, then pull it out again without jerking.

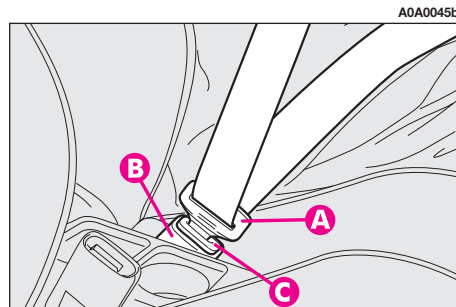

fig. 35

To unfasten the seat belts: press button (C-fig. 35). Guide the seat belt with your hand while it is rewinding, to prevent it from twisting. Through the reel, the belt automatically adapts to the body of the passenger wearing it, allowing freedom of movement.

When the car is parked on a steep slope the reel mechanism may block; this is normal. The reel mechanism prevents the webbing coming out when it is jerked or if the car brakes sharply, in a collision or when cornering at high speed.

 **Never press button (C) when travelling.**

FRONT SEAT BELT HEIGHT ADJUSTMENT

Always adjust the height of the belts adapting it to the person who is wearing it. This precaution improves their effectiveness substantially reducing the risk of injury in the event of a crash.

Correct adjustment is obtained when the belt passes half way between the end of the shoulder and the neck.

The front seat belt ring can take 4 different positions which make it possible to adjust the height of the belts.

To adjust, press button (A-fig. 36) and lower or raise the grip (B).



Always adjust the seat belt height when the car is stationary.



After adjustment, always check that the slider is anchored in one of the positions provided. To do this, with the button (A) released, exert a further pressure to allow the anchor device to catch if release did not take place at one of the preset positions.

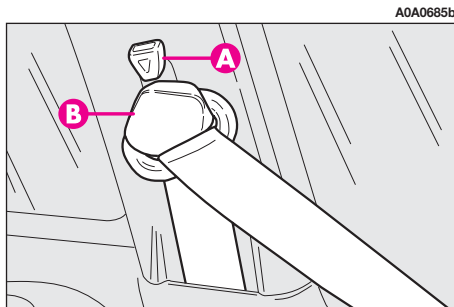

fig. 36

REAR BELTS

To fasten the belt: gently pull the belt from its reel and guide the tape to prevent it from twisting, then insert the tongue (A-fig. 37) into the buckle housing (B).

To unfasten the seat belts, press button (E).

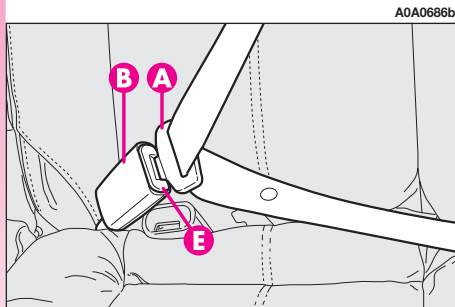

fig. 37

Rear seat belts shall be worn as shown in **fig. 38**. **Fig. 39** shows improper belt fastening. To tilt the back rest see paragraph "Boot extension".

IMPORTANT The centre rear seatbelt is installed on request only for versions/markets on which it is required.

IMPORTANT Remember that, in the event of an accident, any passengers occupying the rear seats who are not wearing a seat belt not only subject themselves to great personal risk, but constitute a danger to the occupants of the front seats.

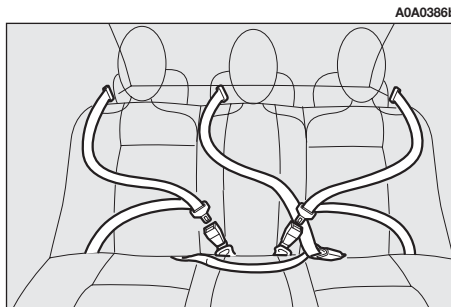

fig. 38

PRE-TENSIONING DEVICES

To increase the efficiency of the front seat belts, the car is fitted with pre-tensioning devices. These devices "feel" that the car is being subject to a violent impact by way of a sensor and rewind the seat belts a few centimetres. In this way they ensure that the seat belt adheres to the wearer before the restraining action begins.

The seat belt locks to indicate that the device has intervened; the seat belt cannot be drawn back up even when guiding it manually.

IMPORTANT The pretensioner will give maximum protection when the seat belt adheres snugly to wearer's chest and hips.

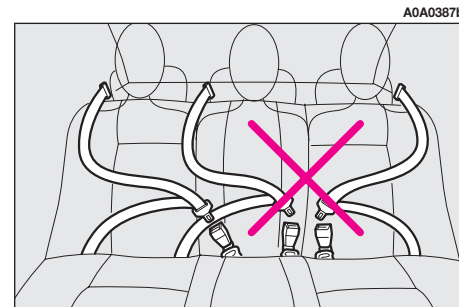

fig. 39

Pretensioner activation may produce a small amount of smoke. This smoke is in no way toxic and presents no fire hazard.

The emergency tensioning retractor needs no maintenance or lubrication. Any modification to its original features will nullify the retractor effectiveness. If, due to unusual natural events (floods, high waves, etc.), the device has been affected by water and mud, it must be replaced.



Pre-tensioning devices can only be used once. After they have been triggered contact Alfa Romeo Authorised Services to have them replaced. The validity of the device is 10 years from the date of production on the sticker; the pretensioners should be changed at an Alfa Romeo Authorised Service as this date approaches.



Operations involving banging, vibrations or heating (above 100°C for a maximum of 6 hours) in the area of the pretensioners may damage or trigger off the device. Vibrations from rough road surfaces or accidental jolting caused by mounting pavements etc. do not have any effect on the pretensioner. If, however, you need assistance, go to Alfa Romeo Authorised Services.

LOAD LIMITERS

To increase passengers' protection in the event of an accident, the front and rear (where provided) seat belt reels contain a load limiter which allows controlled sag in such a way as to dose the force acting on the shoulders and chest during the belt restraining action in case of a crash.

GENERAL INSTRUCTIONS FOR THE USE OF THE SEAT BELTS

All the occupants of the car are obliged to respect the local traffic laws regarding the wearing of seat belts.

Always fasten the seat belts before starting.

Seat belts are also to be worn by expectant mothers: the risk of injury in the case of accident is greatly reduced for them and the unborn child if they are wearing a seat belt. Pregnant women must of course position the lower part of the belt very low down so that it passes under the abdomen (as illustrated in **fig. 40**).

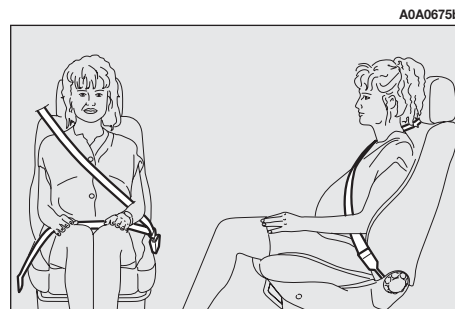

fig. 40

IMPORTANT The seat belt must not be twisted. The upper part must pass over the shoulder and diagonally across the chest. The lower part must rest across the pelvis and not across the (fig. 41) stomach. Do not use devices (clips, stoppers, etc.) which keep the belts away from the body.

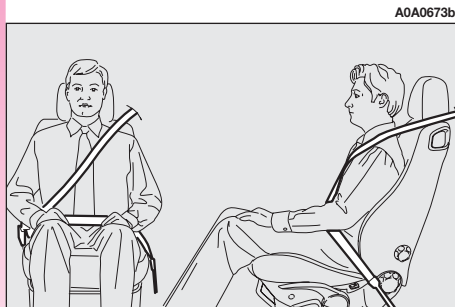



fig. 41

 **To ensure the highest degree of protection, you are recommended to keep the seat backrest in the straightest position possible, and the belt adhering well to the chest and pelvis. Seat belts should always be worn in both the front and rear positions! Travelling without seat belt increases the risk of serious injury or death in the case of accident.**

IMPORTANT Each seat belt shall be worn only by one person: do not carry children on your knee using a single seat belt for both (fig. 42). Do not fasten other objects to the body.

 **Under no circumstances should the components of the seat belt and pretensioner be tampered with or removed. Any operation should be carried out by qualified and authorised personnel. Always contact an Alfa Romeo Authorised Service.**



fig. 42



If the seat belt has been subjected to shock, for example during an accident, it must be completely replaced together with the attachments and their screws, and the pretensioning devices, even if visible defects are not detected, as the belt may have lost its resilience.

HOW TO KEEP THE SEAT BELTS ALWAYS IN EFFICIENT CONDITIONS

To keep the seat belts always in efficient conditions, observe the following:

- always use the belts with the tape well taut and never twisted; make sure that it is free to run without impediments;
- after a serious accident, replace the belt being worn at that time, even if it does not appear damaged. Always replace the seat belts if pretensioners have been activated;
- to clean the belts, wash by hand with neutral soap, rinse and leave to dry in the shade. Never use string detergents, bleach or dyes or any other chemical substance that might weaken the fibres;

— prevent the reels from getting wet: their correct operation is only guaranteed if water does not get inside;

— replace the seat belt if it shows significant wear or cut signs.

CARRYING CHILDREN SAFELY

For optimal protection in the event of a crash, all passengers must be seated and wearing adequate restraint systems. This is even more important for children.

This prescription is compulsory in all EC countries according to EC Directive 2003/20/EC.

Compared with adults, their head is proportionally larger and heavier than the rest of the body, while the muscles and bone structure are not completely developed. Therefore, correct restraint systems are necessary, other than adult seat belts.

The results of research on the best protection for a child are summarised in European Standard ECE- R44, which in addition to making them compulsory, subdivides restraint systems into five groups:

Group 0	0 - 10 kg in weight
Group 0+	0 - 13 kg in weight
Group 1	9 - 18 kg in weight
Group 2	15 - 25 kg in weight
Group 3	22 - 36 kg in weight

As it may be noted, the groups overlap partly and in fact, in commerce it is possible to find devices that cover more than one weight group. All restraint devices must bear the certification data, together with the control brand, on a solidly fixed label which must absolutely never be removed.

Over 1.50 m in height, from the point of view of restraint systems, children are considered as adults and wear the seat belts normally. Lineaccessori Alfa Romeo offers seats for each weight group, which are the recommended choice, as they have been designed and experimented specifically for Alfa Romeo cars.



Never place cradle child's seats facing backwards on the front passenger seat of cars fitted with passenger's air bag since the air bag activation could cause serious injuries, even mortal. You are advised to carry children always on the rear seat, as this is the most protected position in the case of a crash.



SERIOUS DANGER
Children may placed on the front seat of cars fitted with passenger's air bag deactivation. In this case, it is absolutely necessary to check the warning light  on the instrument panel to make sure that deactivation has actually took place (see paragraph "Front passenger air bag"). The front passenger's seat shall be adjusted in the most backward position to prevent any contact between child's seat and dashboard.

GROUP 0 AND 0+ (fig. 43)

Babies up to 13 kg must be carried facing behind on a cradle seat which, supporting the head, does not induce strain on the neck in the event of a sharp deceleration.

The cradle is restrained by the car safety belts, as illustrated, and it should in turn restrain the child with the belts incorporated on it.

A0A0659b



fig. 43

GROUP 1 (fig. 44)

Starting from 9 to 18 kg in weight, children may be carried facing forwards with seats fitted with front cushion, through which the car seat belt restrains both child and seat.

A0A0660b



fig. 44



The illustration is indicative only for assembly. Assemble the seat according to the compulsory instructions provided with it.



Seats exist which are suitable for covering weight groups 0 and 1 with a rear connection to the car belts and its own belts to restrain the child. Because of their mass, they can be dangerous if installed incorrectly fastened to the car belts with a cushion. Strictly adhere to the assembly instructions provided.

GROUP 2 (fig. 45)

Starting from 15 to 25 kg in weight, children may be restrained directly by the car seat belts.

Child seats only have the function of positioning the child correctly in relation to the belts, so that the diagonal part adheres to the chest and never to the neck and that the horizontal part adheres to the child's pelvis and not to the abdomen.

A0A0661b

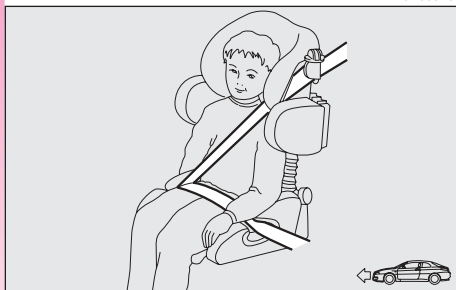

fig. 45

GROUP 3 (fig. 46)

For children from 22 up to 36 kg the child's chest is thick enough not to need the spacer back rest anymore.

The figure shows proper child seat positioning on the rear seat.

Over 1.50 m in height, children may wear seat belts like adults.

A0A0662b



fig. 46



The illustration is indicative only for assembly. Assemble the seat according to the compulsory instructions provided with it.

PASSENGER SEAT COMPLIANCE WITH REGULATIONS ON CHILD'S SEAT USE

Your car complies with the new European Directive 2000/3/EC regulating child's seat assembling on the different car seats according to the following table:

Group	Range of weight	Front passenger	Rear passengers	Central passenger
Group 0, 0+	up to 13 kg	U	U	U
Group 1	9-18 kg	U	U	U
Group 2	15-25 kg	U	U	U
Group 3	22-36 kg	U	U	U

Key:

U = suitable for child restraint systems of the "Universal" category, according to European Standard EEC-R44 for the specified "Groups".

Below is a summary of the rules of safety to be followed for carrying children:

– The recommended position for installing a child's seat is on the rear seat, as it is the most protected in the event of a crash.

– If the passenger's air bag is deactivated **always** check warning light  on the cluster to make sure that it has actually been deactivated.

– Carefully follow the instructions provided with the child's seat, which the supplier is obliged to attach. Keep them in the car together with the documents and this booklet. Do not use used seats without the instructions for use.

– Always pull the tape to check that belts are buckled.

– All restraint systems are strictly for one child only: never use for two children at the same time.

– Always make sure that the belts do not rest on the child's neck.

– During the journey, do not allow the child to stay in abnormal positions or release the belts.

– Do not carry children in your arms, not even small babies. No-one, however strong, can keep hold of them in a crash.

– In the case of accidents, replace the child's seat with a new one.



Never place cradle child's seats facing backwards on the front passenger seat of cars fitted with passenger's air bag since the air bag activation could cause serious injuries, even mortal. You are advised to carry children always on the rear seat, as this is the most protected position in the case of a crash.

PRESETTING FOR MOUNTING "ISOFIX TYPE" CHILD RESTRAINT SYSTEM

The rear seat of your car is preset for mounting the Isofix type child restraint system, a new European standardised system for carrying children safely. Isofix type child restraint system is an additional option that does not prevent from using traditional child restraint systems. Isofix type child restraint system covers three weight groups: 0, 0+ and 1.

Due to its different anchoring system, the Isofix child' seat shall be anchored just using the metal brackets (**A-fig. 47**) set between rear seat back and cushion.

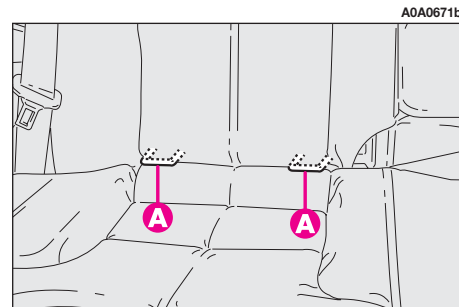

fig. 47

It is actually possible to mount both the traditional restraint system and the Isofix one, e.g. the traditional one on the left and the Isofix type seat on the right.

Since sizes are different, on the rear seats it is possible to install just two traditional child's seats, or two Isofix type seats. On the front passenger seat it is only possible to mount traditional child's seats.

Only Isofix type child restraint systems designed and tested for this car must be used.



Mount the child restraint system only with the car stationary. The Isofix child restraint system is properly anchored to the mounting brackets when clicks are heard. In any case, keep to the installation instructions that must be provided by the child restraint system Manufacturer.

MOUNTING THE ISOFIX TYPE CHILD'S SEAT

Groups 0 and 0+

For children of the 0 and 0+ group (babies up to 13 Kg), the child's seat is facing backwards and the child is restrained by the child's seat belts (**D-fig. 48**).

As the child grows, passing to weight group 1, the child's seat shall be fitted facing forwards.

For proper mounting proceed as follows:

- check whether the release lever (**B**) is at rest position (inward);
- find the presetting brackets (**A**), then position the child restraint system with the fastening devices (**C**) aligned with the brackets;

– push the child restraint system until hearing the locking clicks;

– check proper locking by moving the child's seat with force: the built-in safety mechanism actually inhibits proper coupling with only one coupling locked.

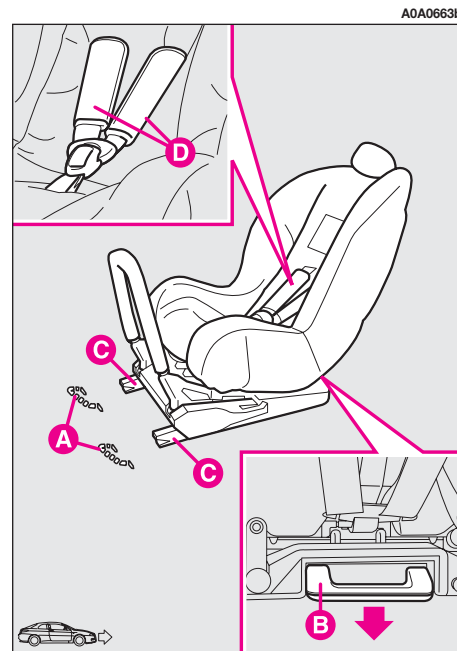

fig. 48

Group 1

For proper mounting proceed as follows:

- check whether the release lever (**B**-fig. 49) is at rest position (inward);
- find the presetting brackets (**A**), then position the child restraint system with fastening devices (**C**) aligned with the brackets;
- push the child restraint system until hearing the locking clicks;
- check proper locking by moving the child's seat with force: the built-in safety mechanism actually inhibits improper coupling with only one coupling locked.

With this configuration, the child is secured also by the car seat belts and by the upper belts. To apply car seat belts to child's seat refer to the child's seat handbook.

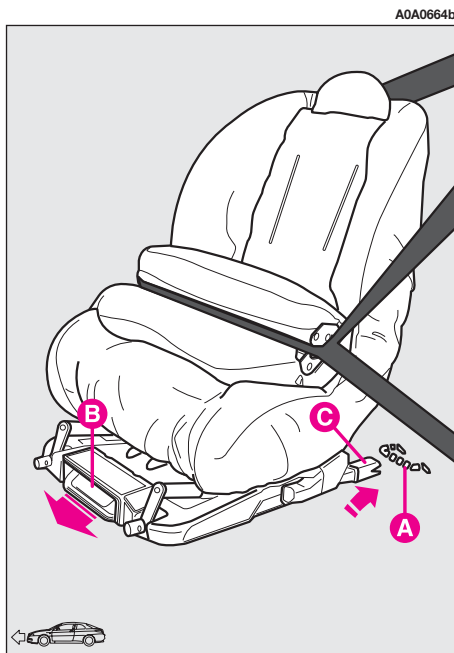

fig. 49

AIR BAG

The car is fitted with front air bags for the driver and for the passenger (side bags - window bags).

FRONT AIR BAGS

The front air bag (driver's and passenger's) has been designed to protect the occupants in the event of head-on crashes of medium-high severity by placing the cushion between the occupant and the steering wheel or dashboard.

Front air bags are designed to protect the car occupants in front crashes and therefore non-activation in other types of collisions (side collisions, rear-end shunts, roll-overs, etc...) is not a system malfunction.

In the case of a crash, an electronic control unit, when necessary, triggers inflation of the cushion.

The cushion inflates instantaneously, setting itself between the body of the front occupants and the structures that could cause injury. The cushion then deflates immediately afterwards.

The front air bag (driver's and passenger's) does not replace but is complementary to the use of belts, which should always be worn, as specified by law in Europe and most non-European countries.

In the event of a crash a person that is not wearing the seat belt moves forwards and may come into contact with the cushion while it is still opening. Under these circumstances the protection offered by the cushion is reduced.

Front air bags may not be triggered in the following conditions:

- collisions against highly deformable objects which do not concern the car front surface (for example the bumper crashing against the guard rail);

- wedging under other cars or protective barriers (for example under a lorry or guard rail);

as they do not offer any more protection than the seat belts and therefore activation would be inappropriate. Therefore the failure to be triggered does not mean that the system is not working properly.



Do not apply stickers or other objects on the steering wheel and on the passenger's air bag cover. Do not put objects on the dashboard on the passenger's side (e.g. cell phones) because they may interfere with the correct passenger's air bag opening and seriously injure the occupants of the car.

The driver's and passenger's front air bag has been designed to improve the protection of a person wearing a seat belt.

Its volume at maximum inflation fills most of the space between the steering wheel and the driver and between the dashboard and the passenger.

In the event of minor side crashes (for which the restraining action of the seat belts is sufficient), the air bags are not deployed. Also in this case it is of vital importance to wear the seat belts since in case of side crash they guarantee proper positioning of the occupant.

DRIVER'S FRONT AIR BAG

It consists of an instant-inflating cushion contained in a special recess in the centre of the steering wheel (**fig. 50**).

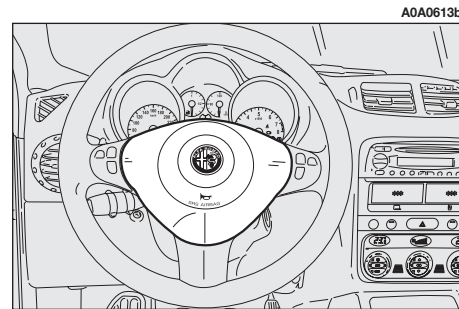

fig. 50

PASSENGER'S FRONT AIRBAG

It consists of an instant-inflating cushion contained in a special recess in the dashboard; its volume is bigger than the driver's one (fig. 51).



Never place cradle child's seats facing backwards on the front passenger seat of cars fitted with passenger's air bag since the air bag activation could cause serious injuries, even mortal. You are advised to carry children always on the rear seat, as this is the most protected position in the case of a crash.



fig. 51



SERIOUS DANGER
Children may placed on the front seat of cars fitted with passenger's air bag deactivation. In this case, it is absolutely necessary to check the warning light  on the instrument panel to make sure that deactivation has actually took place (see paragraph "Front passenger air bag"). The front passenger's seat shall be adjusted in the most backward position to prevent any contact between child's seat and dashboard.

MANUAL DEACTIVATION OF PASSENGER'S FRONT AIRBAG (fig. 52) (upon request for versions / markets where applicable)

Should it be absolutely necessary to carry a child on the front seat, the passenger's front air bag can be deactivated.

Deactivation/reactivation takes place with ignition key at **STOP**, and operating it in the special key switch set in the glovebox.

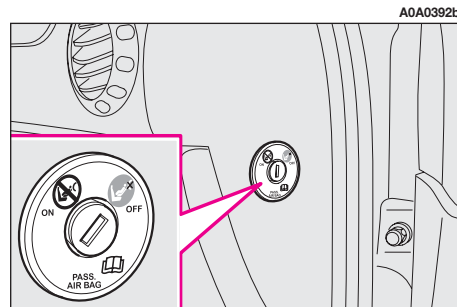





fig. 52

The key can be inserted and removed in both positions.

IMPORTANT Operate the switch only when the engine is not running and the ignition key is removed.

The key-operated switch has two positions:

– passenger’s front airbag activated (**ON** position ): warning light  on instrument cluster off; it is absolutely prohibited to carry a child on the front seat.

– passenger’s front airbag deactivated (**OFF** position ): warning light  on instrument cluster on; it is possible to carry a child protected by special restraint system on the front seat.

The warning light  on the cluster stays on permanently until the passenger’s air bag is reactivated.

Deactivation of the passenger’s front air bag does not inhibit operation of the side air bag.

SIDE AIR BAGS (SIDE BAG - WINDOW BAG)

SIDE BAG (fig. 53)

The side bag is formed of an instantaneously-inflating cushion housed in the back rest of the front seat and protects the chest of occupants in case of a side crash of medium-high severity.

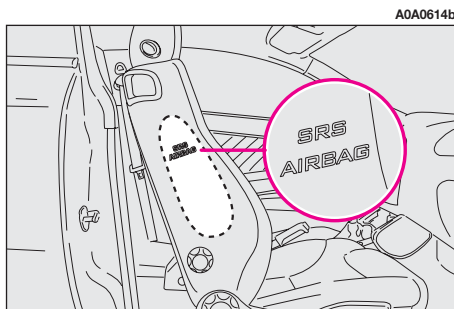

fig. 53

WINDOW BAG (fig. 54)

The window bag is formed of two “curtain” cushions housed in the side roof lining covered by a special trim, which protects the head of front and rear occupants in the event of a side crash thanks to the wide cushion inflation surface.

IMPORTANT In the event of side crash, you can obtain the best protection by the system keeping a correct position on the seat, thus allowing correct window bag unfolding.

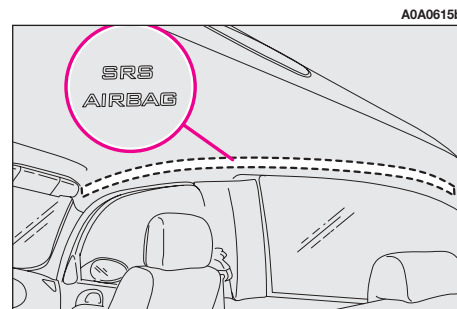

fig. 54

IMPORTANT The front and/or side air bags may be activated if the car is subjected to heavy shocks or accidents that involve the underbody area, such as for example violent bumps against steps, pavements or fixed obstacles on the ground, falling into big holes or bumpy roads.

IMPORTANT The triggering of air bags releases a small amount of powder. This powder is not harmful and does not indicate a start of fire; also the surfaces of the deployed bag and the car interior may be covered with dusty residue: this may irritate the skin and eyes. In the event of exposure, wash with neutral soap and water.

Life and validity of pyrotechnic charge and coil contact are indicated on the label set near the lock of the left front door. As this date approaches, contact Alfa Romeo Authorized Services to have the device replaced.

IMPORTANT Should an accident occur in which any of the safety devices is activated, take the car to Alfa Romeo Authorized Services to have the devices activated replaced and to have the system checked.

All operations involving checking, repairing and replacing components concerning the air bag must be carried out by Alfa Romeo Authorised Services

If the car is to be demolished, Alfa Romeo Authorised Services should be contacted beforehand to have the system deactivated. If the car changes ownership, the new owner must be informed of the instructions for use and of the above warnings and be given this "Owner's Manual".

IMPORTANT The triggering of the pretensioners, front air bags and side bags is decided in a differentiated manner depending on the type of crash. The failure to trigger one or more of them does not necessarily indicate a system malfunction.



Never rest head, arms and elbows on the door, on the windows and in the window bag area to prevent possible injuries during the inflation phase.



Never lean head, arms and elbows out of the window.

GENERAL CAUTIONS



If when turning the ignition key to MAR, the warning light  does not turn on or if it stays on when travelling there could be a failure in safety systems; in this event air bags or pretensioners could not trigger in case of impact or, in a minor number of cases, they could trigger accidentally. Contact Alfa Romeo Authorized Services immediately to have the system checked.



Do not cover the backrest of front seats with trims or covers that are not suitable to be used with side bags.



Never travel with objects on your lap, in front of your chest or with a pipe, pencil, etc. between your lips; injury may result in the event of the air bag being triggered.



Always keep your hands on the steering wheel rim when driving, so that if the air bag is triggered, it can inflate without meeting any obstacles which could cause serious harm to you. Do not drive with the body bent forwards, keep the seat back rest in the erect position and lean your back well against it.



If the car has been stolen or an attempt to steal it has been made, if it has been subjected to vandals or floods, have the air bag system checked by Alfa Romeo Authorized Services.



Remember that with the key engaged and at MAR, even if the engine is not running, the air bags may be triggered on a stationary car if it is bumped by another moving car. Therefore, never seat children on the front seat even when the car is stationary. On the other hand remember that if the key is at STOP, no safety system (air bags or pretensioners) is triggered in the event of an impact; in this case, failure to come into action cannot be considered as a sign that the system is not working properly.



When the ignition key is turned to **MAR**, the warning light  (with passenger's front air bag deactivation switch at **ON**) turns on and flashes for few seconds to remind that passenger's air bag will be deployed in a crash, after which it should go off.



Never wash seat backrests with pressurised water or steam (by hand or at automatic seat washing stations).



The front air bag is triggered for shocks greater in magnitude than the pretensioners. For impacts between these two thresholds, it is therefore normal that only the pretensioners are triggered.



Do not hook rigid objects to the coat hooks and to the support handles.



The air bag does not substitute the seat belts, but only increases their effectiveness. Moreover, since the front air bags do not come into operation in the event of front impact at low speed, side collisions, bumps from behind or overturning, in these circumstances the occupants would only be protected by the seat belts which must therefore always be fastened.

STEERING WHEEL LEVERS

The devices and services controlled by the levers on the steering wheel can only be activated with the ignition key at **MAR**.

LEFT-HAND LEVER

The left-hand lever controls the outer lights except for the fog lamps and rear fog guards.

When the outer lights are switched on, the various controls on the dashboard are illuminated.

Only with the ignition key at **PARK**, regardless of the position of the knurled ring, the sidelights and number plate lights stay on.

Position (**1** or **2**-fig. 60) of the lever causes the turning on only of the sidelights (front and rear), on the right or left respectively.

Lights switched off (fig. 55)

When the pointer in the knurled ring is opposite the symbol **O**, the outer lights are switched off.

Sidelights (fig. 56)

The sidelights are switched on by turning the knurled ring from **O** to .

The  warning light on the instrument cluster will come on at the same time.

Dipped-beam headlights (fig. 57)

These are switched on by turning the knurled ring from  to .

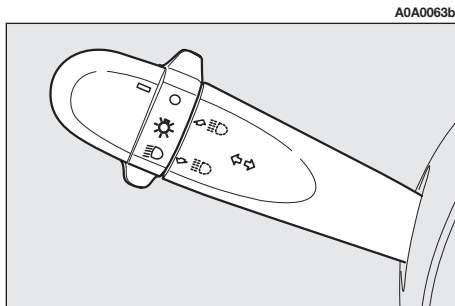

fig. 55

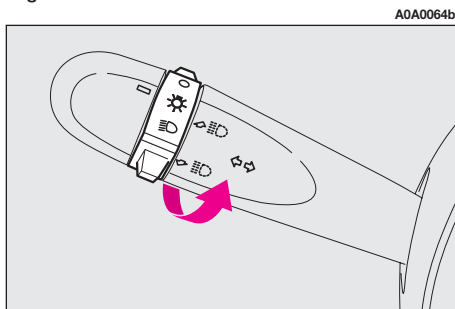



fig. 56

Main beams (fig. 58)

To turn the main beams on, set the knurled ring to position  and push the lever towards the dashboard (stable position); warning light  on the instrument panel will turn on.

To set dipped-beams back pull the lever towards the steering wheel.

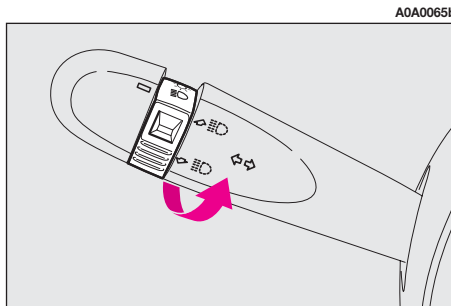

fig. 57

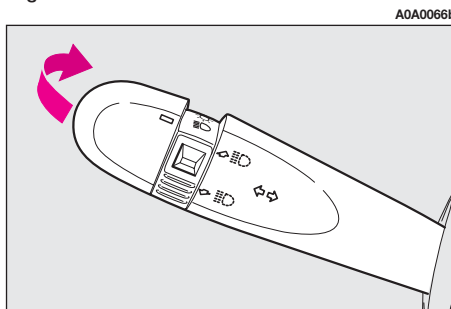

fig. 58

When the dipped beam headlights and the fog lamps are switched on, the outer light control unit (integrated in the Body Computer) works according to the following logics:

- turning on the main beams, the dipped beams turn off while the fog lamps stay on, when restoring the starting condition at dipped beam setting;

or

- turning on the main beams, the fog lamps turn off and then turn on again automatically as the main beams are switched off.

Therefore, in the event of Body Computer replacement, the outer light operating logic may be different.

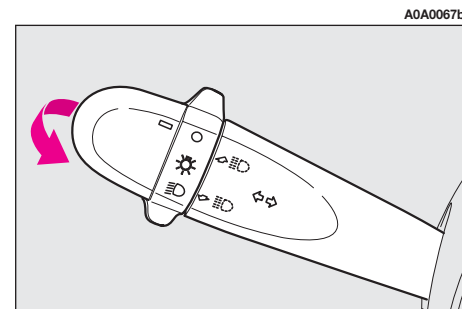



fig. 59

Flashing (fig. 59)

The headlights are flashed pulling the lever towards the steering wheel (instable position) regardless of the position of the knurled ring. The  warning light on the cluster will come on at the same time.

IMPORTANT Only the main-beam lights are flashed. To avoid penalties follow local regulations.

Direction indicators (fig. 60)

Regardless of the position of the knurled ring, moving the lever to the stable position will:

up, position **(1)** - engage the right-hand direction indicators.

down, position **(2)** - engage the left-hand direction indicators.

A0A0068b

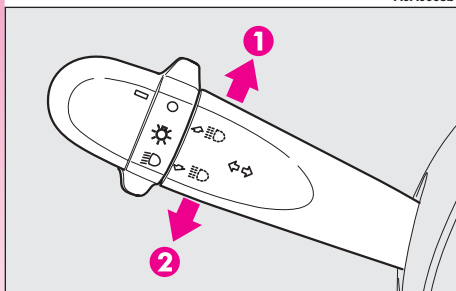



fig. 60

One of the warning lights ( or ) will come on on the instrument cluster at the same time.

The lever is returned to its position automatically and the indicators are switched off when the steering wheel is straightened.

IMPORTANT If you wish to signal a rapid change of direction involving only a minimal movement of the steering wheel, the lever can be removed up or down without it clicking (unstable position). When released, the lever will return to its home position.

“Follow me home” device (fig. 61)

This function allows the illumination of the space in front of the car for the length of time set, and is activated with the ignition key at **STOP** or removed, pulling the left-hand lever towards the steering wheel.

This function is activated pulling the lever within 2 minutes from when the engine is turned off. At each single movement of the lever, the staying on of the dipped beams and sidelights is extended by 30 seconds up to a maximum of 3.5 minutes; the lights switch off automatically after the time set.

Each time the lever is operated, the  warning light on the cluster turns on.

A0A0067b

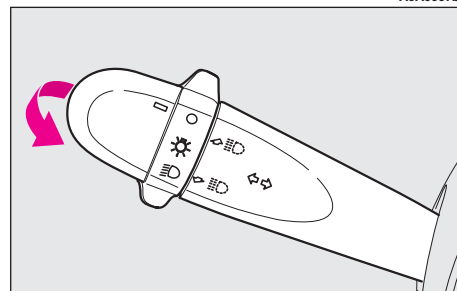

fig. 61

This function can be interrupted by keeping the lever pulled towards the steering wheel for more than 2 seconds.

RIGHT-HAND LEVER

The right-hand lever is used to operate the windscreen wiper-washer and rear screen wiper-washer. The windscreen washer also activates the headlamp washers, if fitted.

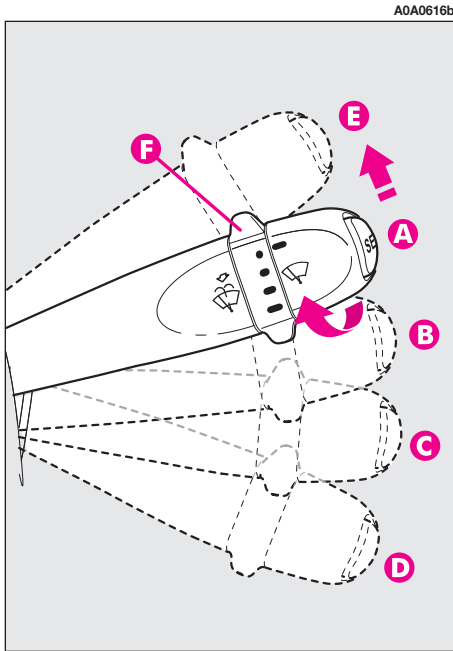

fig. 62

Windscreen wiper-washer (fig. 62-63)

The lever can be moved to five different positions, corresponding to:

A - Windscreen wiper off.

B - Intermittent.

With the lever in position (**B**), turning the ring (**F**), four possible intermittent speeds are obtained:

■ = intermittent slow.

■ ■ = intermittent medium.

■ ■ ■ = intermittent medium-fast.

■ ■ ■ ■ = intermittent fast.

C - Continuous, slow.

D - Continuous, fast.

E - Fast, temporary (unstable position).

Operation in position (**E**) is limited to the time the lever is held in this position. When the lever is released, it returns to position (**A**) automatically stopping the wiper.

“Intelligent washing” function

Pulling the lever towards the steering wheel (unstable position) operates the windscreen washer.

Keeping the lever pulled, with only one movement it is possible to operate the washer jet and the wiper at the same time; indeed, the latter comes into action automatically if the lever is pulled for more than half a second.

The wiper stops working a few strokes after releasing the lever; a further “cleaning stroke” after a few seconds completes the wiping operation.

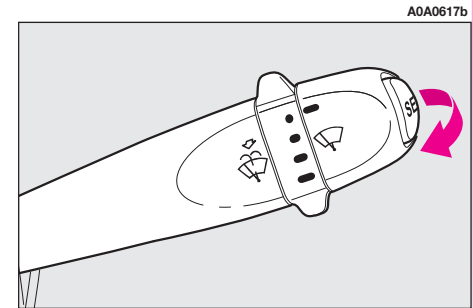

fig. 63

Rain sensor (fig. 64)

The rain sensor (**A**), fitted only on certain versions, is an electronic device combined with the windscreen wiper which has the purpose of automatically adjusting the number of wipes during intermittent operation to the intensity of the rain.

All the other functions controlled by the right-hand lever remain unchanged.

The rain sensor is activated automatically moving the right-hand lever to position (**B**-fig. 62) and it has a range of adjustment that gradually varies between wiper stationary (no wiping) when the windscreen is dry, to wiper at first continuous speed (continuous, slow) with heavy rain.

Turning the knurled ring (**F**-fig. 62) it is possible to increase the sensitivity of the rain sensor, obtaining a quicker change from stationary, when the windscreen is dry, to first continuous speed (continuous, slow).

Operating the windscreen washer with the rain sensor activated (lever at position **B**) the normal washing cycle is performed at the end of which the rain sensor resumes its normal automatic function.

Turning the ignition key to **STOP** the rain sensor is deactivated and the next time the engine is started (**MAR** position) it will not be reactivated even if the lever has remained in position (**B**). In this case to activate the rain sensor, simply move the lever to (**A**) or (**C**) and then back to (**B**).

When the rain sensor is reactivated in this way, the wiper performs at least one stroke, even if the windscreen is dry, to indicate that reactivation has occurred.

The rain sensor is located behind the inner rear-view mirror in contact with the windscreen and inside the area cleaned by the wiper and it controls an electronic control unit which in turn controls the wiper motor.

At each start, the rain sensor automatically stabilises at a temperature of about 40°C to eliminate any condensation from the control surface and prevent the formation of ice.

The rain sensor is able to detect and automatically adapt to the presence of the following particular conditions which require different sensitivity:

- impurities on the control surface (salt, dirt, etc.);
- streaks of water caused by worn wiper blades;
- difference between day and night (the human eye is more disturbed during the night by the wet glass surface).

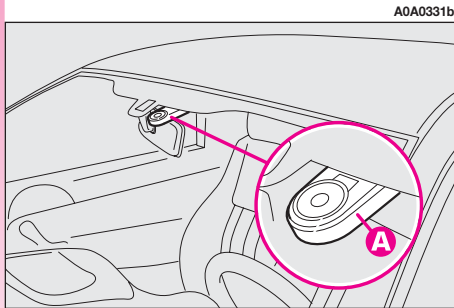

fig. 64

Headlamp washers (fig. 65)

These come into operation when the wind-screen washer is turned on with the dipped/main beam headlights on.

IMPORTANT On certain versions when the headlamp washer is operating, the climate control system automatically engages inside air re-circulation, to prevent the smell of liquid detergent from entering the passenger compartment.

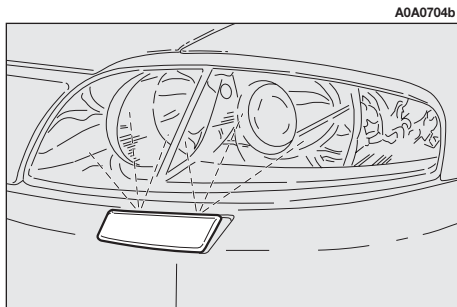



fig. 65

CRUISE CONTROL

GENERAL

The speed regulator (**CRUISE CONTROL**), with electronic control, makes it possible to drive the car at the required speed without pressing the accelerator pedal. This reduces driving fatigue during long journeys because the speed memorised is automatically maintained.

IMPORTANT The device can only be engaged at speeds between 30 and 190 km/h.

 **Cruise Control must be activated only when the route and traffic allow a constant speed for a sufficiently long distance completely safely.**

The device is disengaged automatically in any of the following cases:

- pressing the brake pedal;
- pressing the clutch pedal;
- if the ASR, MSR or ESP system cuts in;
- with Selespeed transmission if a gear is changed;
- inadvertently moving the Selespeed gear control lever to **N**.

CONTROLS (fig. 66)

Cruise Control is controlled by the **ON/OFF** knurled ring (**A**), by the **+/-** ring (**B**) and by the **RES** button (**C**).

Ring (**A**) has two positions:

- **OFF** in this position the device is deactivated;

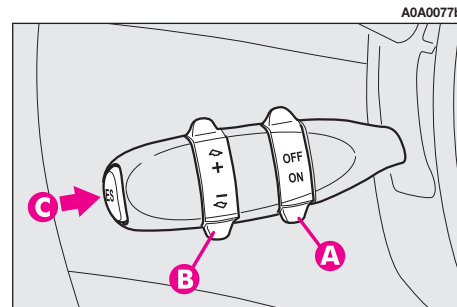



fig. 66

— **ON** is the normal operating position of the device. When the ring (**A**) is in this position, the warning light  on the instrument cluster turns on.

Ring (**B**) serves for memorising and maintaining the car speed or for increasing or lowering the speed memorised.

Turn the ring (**B**) to **(+)** to memorise the speed reached or increase the speed memorised.

Turn the ring (**B**) to **(-)** to lower the speed memorised.

Each time the ring is actuated (**B**) the speed increases or lowers by about 1.5 km/h.

Keeping the ring turned the speed changes continuously. The new speed reached will be maintained automatically.

The **RES** button (**C**) resets the memorised speed.

IMPORTANT Turning the ignition key to **STOP** or the ring (**A**) to **OFF**, the speed memorised is cleared and the system is switched off.

TO MEMORISE THE SPEED

Move the ring (**A**) to **ON** and take the car to the required speed normally. Turn the ring (**B**) to **(+)** for at least three seconds, then release it. The car speed is memorised and it is therefore possible to release the accelerator pedal.

The car will continue to travel at the memorised constant speed until one of the following conditions takes place:

- pressing the brake pedal;
- pressing the clutch pedal;
- if the ASR, MSR or ESP system cuts in;
- with Selespeed transmission if a gear is changed;
- inadvertent movement of the Selespeed gear control lever to position **N**.

IMPORTANT In the case of need (when overtaking for instance) acceleration is possible simply pressing the accelerator pedal; later, releasing the accelerator pedal, the car will return to the speed memorised previously.

TO RESET THE MEMORISED SPEED

If the device has been disengaged for example pressing the brake or clutch pedal, the memorised speed can be reset as follows:

- accelerate gradually until reaching a speed approaching the one memorised;
- engage the gear selected at the time of speed memorising (4th, 5th or 6th speed);
- press the **RES** button (**C**).

TO INCREASE THE MEMORISED SPEED

The speed memorised can be increased in two ways:

1) pressing the accelerator and then memorising the new speed reached (turning the ring to **(B)** for more than three seconds);

or

2) momentarily turning the ring (**B**) to **(+)**: each pulse of the ring will correspond to a slight increase in speed (about 1.5 km/h) while pressing continuously will correspond to a continuous speed increase. Releasing the ring (**B**) the new speed will be memorised automatically.

TO REDUCE THE MEMORISED SPEED

The speed memorised can be reduced in two ways:

1) disengaging the device (for instance pressing the brake pedal) and then memorising the new speed (turning the ring **(B)** to **(+)** for at least three seconds);

2) keeping the ring pressed **(B)** at **(-)** until reaching the new speed which will be memorised automatically.

TO RESET THE MEMORISED SPEED

The memorised speed is automatically reset turning off the engine or moving the ring **(A)** to **OFF**.



When travelling with the cruise control on, do not move the gearshift lever to neutral and do not move the Select-speed selector to N.

It is advisable to engage the cruise control only when the conditions of the traffic or roads so permit under completely safe conditions, i.e.: straight and dry roads, dual carriage ways or motorways, flowing traffic and smooth road surface. Do not engage the device in town or in heavy traffic conditions.



Cruise control may only be engaged at speeds between 30 and 190 km/h.

The device may only be engaged in in 4th, 5th or 6th gear, depending on the speed of the car. Travelling downhill with the device engaged the car speed may increase more than the memorised one, due to the change in the engine load.



If the device is faulty or not working, turn the ring (A) to OFF and contact Alfa Romeo Authorised Services after checking that the protection fuse is intact.

The ring **(A)** may be left constantly at **ON** without damaging the device. You are, however, advised to switch the device off when not in use, turning the ring to **OFF**, to avoid memorising speeds by accident.

DASHBOARD

(For right-hand drive versions see dashboard and instruments in the dedicated paragraph at the end of the manual)

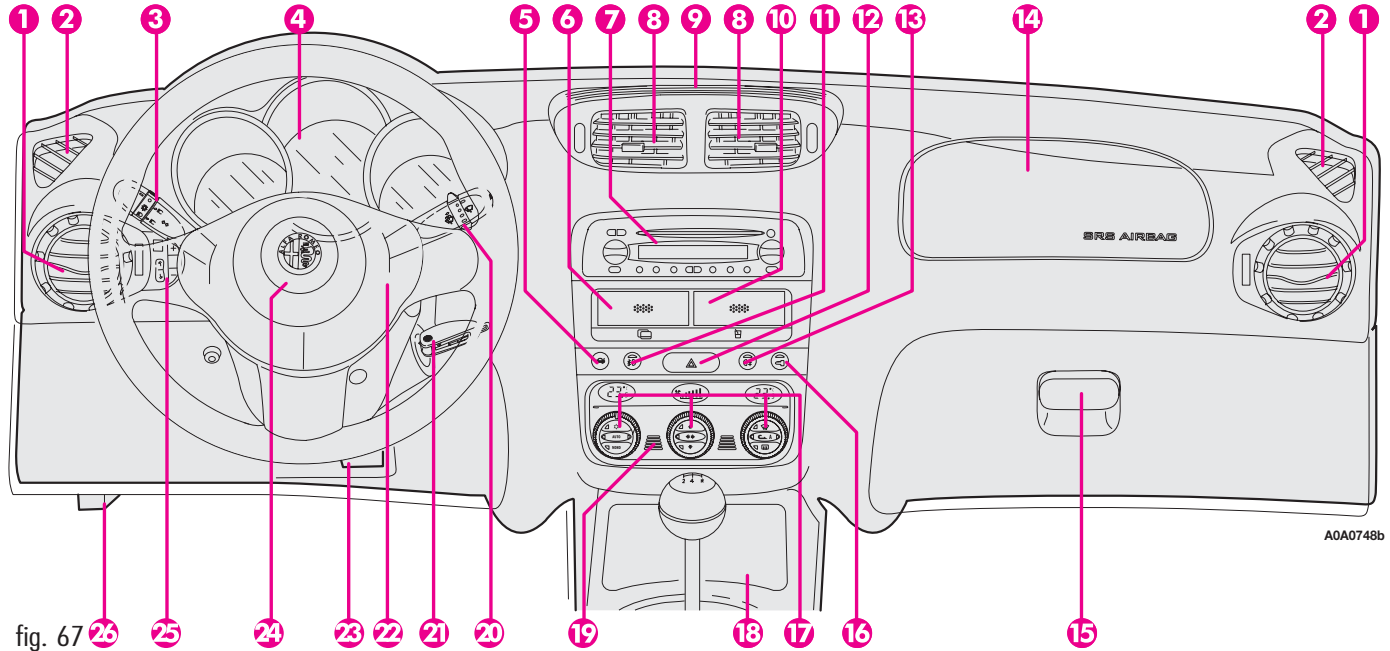

A0A0748b

fig. 67

1. Adjustable side air vents - **2.** Fixed side window air vents - **3.** External lights control lever - **4.** Instrument panel - **5.** Tailgate release button - **6.** Cards holder (for versions/markets where applicable) - **7.** Sound system (for versions/markets where applicable) - **8.** Adjustable central air vents - **9.** Upper fixed vent - **10.** Glass/can holder (for versions/markets where applicable) - **11.** Front fog light button - **12.** Hazard light switch - **13.** Rear fog light button - **14.** front passenger's air bag - **15.** Glovebox - **16.** Door locking button - **17.** Heating, ventilation/climate controls - **18.** Cigar lighter/ashtray housing lid - **19.** Temperature sensor - **20.** Windscreen wiper stalk - **21.** Ignition key and ignition switch - **22.** Horn - **23.** Steering wheel locking/release lever - **24.** Driver's air bag - **25.** Set of controls - **26.** Bonnet opening lever.

INSTRUMENT PANEL

A. Fuel level gauge with reserve warning light - **B.** Engine coolant fluid temperature gauge with maximum temperature warning light - **C.** Speedometer - **D.** Odometer display (mileage recorder, trip meter with headlamp position display) - **E.** Reconfigurable multifunction display - **F.** Rev counter

NOTE On JTDM versions the scale bottom is at 6000 revs.

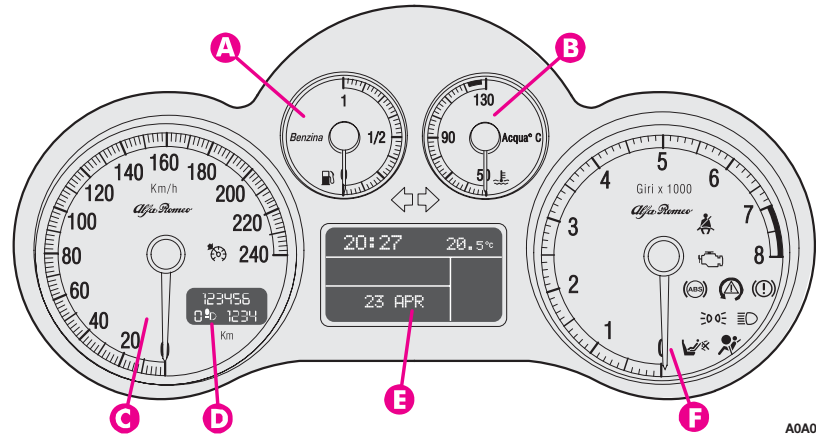

A0A0760B

fig. 68 - petrol versions

A. Fuel level gauge with reserve warning light - **B.** Engine coolant fluid temperature gauge with maximum temperature warning light - **C.** Speedometer - **D.** Odometer display (mileage recorder, trip meter with headlamp position display) - **E.** Reconfigurable multifunction display - **F.** Rev counter

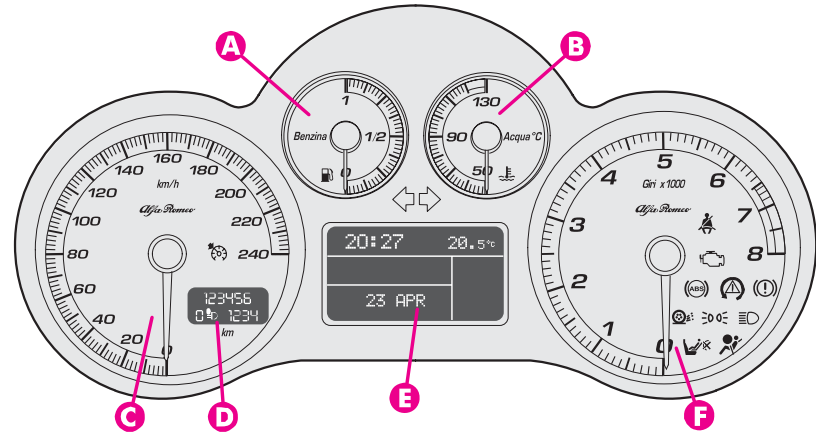

A0A0749B

fig. 69 - Black Line petrol versions

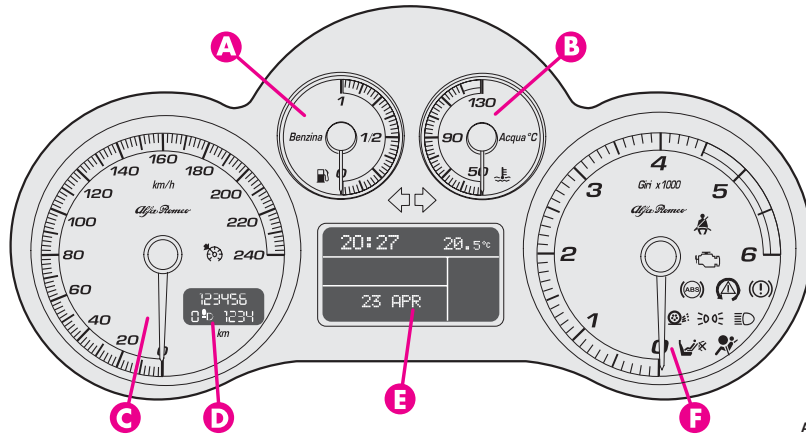

A0A0759b

fig. 70 - Q2 diesel version

A. Fuel level gauge with reserve warning light - **B.** Engine coolant fluid temperature gauge with maximum temperature warning light - **C.** Speedometer - **D.** Odometer display (mileage recorder, trip meter with headlamp position display) - **E.** Reconfigurable multifunction display - **F.** Rev counter

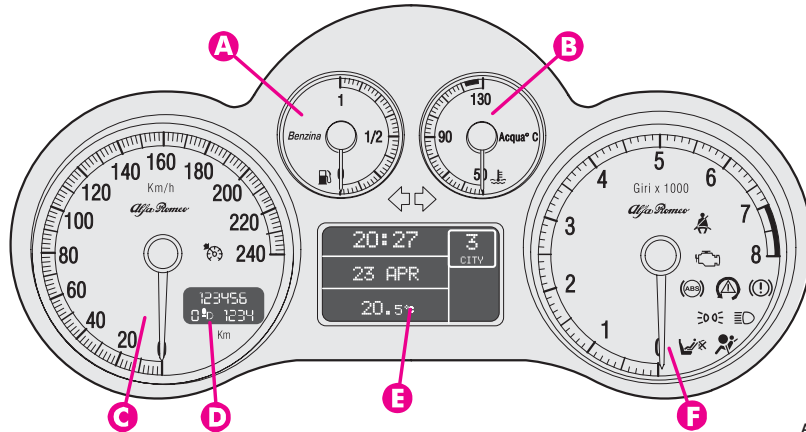

A0A0761b

fig. 71 - 2.0 JTS Selespeed versions

A. Fuel level gauge with reserve warning light - **B.** Engine coolant fluid temperature gauge with maximum temperature warning light - **C.** Speedometer - **D.** Odometer display (mileage recorder, trip meter with headlamp position display) - **E.** Reconfigurable multifunction display - **F.** Rev counter

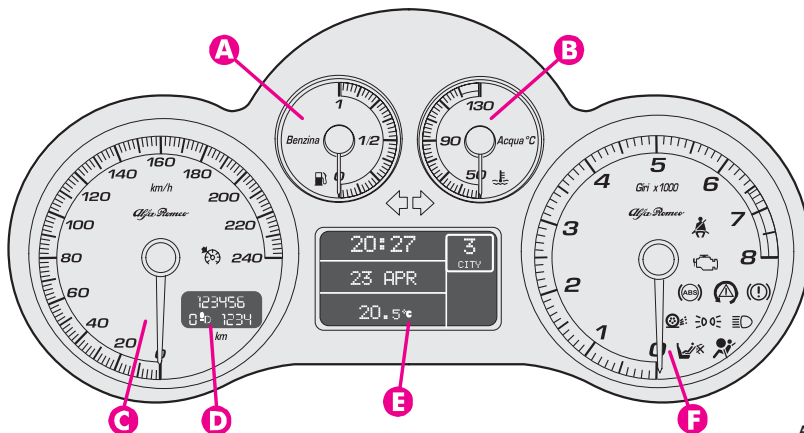

A. Fuel level gauge with reserve warning light - **B.** Engine coolant fluid temperature gauge with maximum temperature warning light - **C.** Speedometer - **D.** Odometer display (mileage recorder, trip meter with headlamp position display) - **E.** Reconfigurable multifunction display - **F.** Rev counter

fig. 71a - 2.0 JTS Selespeed Black Line version

A0A0752b

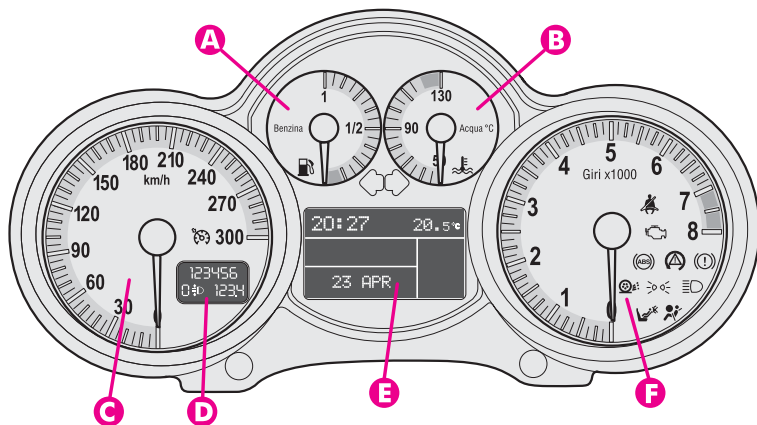

A. Fuel level gauge with reserve warning light - **B.** Engine coolant fluid temperature gauge with maximum temperature warning light - **C.** Speedometer - **D.** Odometer display (mileage recorder, trip meter with headlamp position display) - **E.** Reconfigurable multifunction display - **F.** Rev counter

fig. 71b - 3.2 V6 version

A0A0746b

SPEEDOMETER (SPEED INDICATOR)

The gauge (A-fig. 72) indicates the car speed.

ODOMETER

Odometer display (B-fig. 72) with double meter (total and trip) and headlamp position display.

The display shows:

- the mileage on the first line (6 figures)
- the trip meter on the second line (4 figures)
- aside the position of the headlight aiming device.

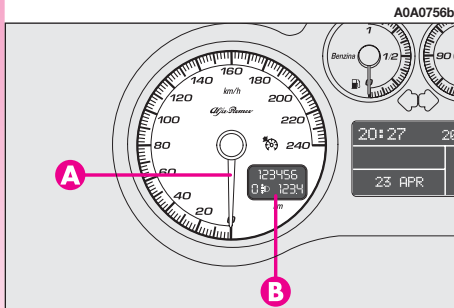

fig. 72

To reset the trip meter, keep button (A-fig. 73) on the plate at the side of the steering column pressed for a few seconds.

IMPORTANT If the battery is disconnected the trip meter reading is not stored.

REV COUNTER (fig. 74)

The danger zone (red, or white on certain versions) indicates excessive high engine speed. Do not drive for long periods with the pointer in this area.

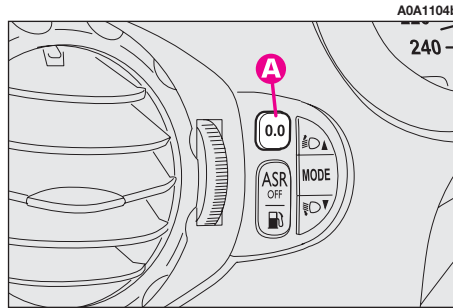

fig. 73

IMPORTANT The electronic injection control system gradually shuts off the flow of fuel when the engine is “over-revving” resulting in a gradual loss of engine power.

When the engine is idling, the rev counter may indicate a gradual or sudden highering of the speed, this is normal as it takes place during normal operation, for example when engaging the climate control system or the fan. In particular a slow change in the speed preserves the battery charge.

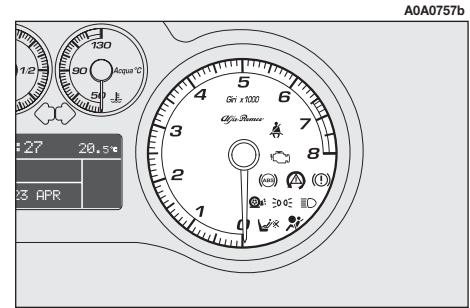

fig. 74

FUEL LEVEL GAUGE WITH RESERVE INDICATOR

This shows the amount of fuel left in the fuel tank.

0 - tank empty.

1 - tank full (see the indications given in paragraph "At the filling station").

The warning light  (**A-fig. 76**) turns on to indicate that approx. 7 litres of fuel are left in the tank.

IMPORTANT The pointer can reach the red area also for a sum of unfavourable conditions, i.e.: slow speed, uphill, fully laden or towing a trailer with hot outside temperature.

IMPORTANT Refuelling shall always be performed with engine off and ignition key at **STOP**. If the engine is off but the key is at **MAR**, a wrong fuel level could temporarily be indicated. This is due to the internal system control logic and cannot be considered as a system malfunctioning.

ENGINE COOLANT FLUID TEMPERATURE GAUGE WITH MAXIMUM TEMPERATURE WARNING LIGHT

This shows the temperature of the engine coolant fluid and begins when the fluid temperature exceeds approx. 50°C.

Normally the pointer should be towards the middle of the scale. If the pointer reaches the higher temperatures of the scale (red section, or white on certain versions) the request for car performance should be decreased.

The turning on of the  (**B-fig. 76**) warning light (on some versions together with the message shown on the reconfigurable multifunction display) indicates that the coolant fluid temperature is too high; in this case, stop the engine and contact Alfa Romeo Authorised Services.

IMPORTANT The temperature of the engine coolant may rise towards the maximum values (red section, or white on certain versions) when the car is driven at low speeds, especially when the ambient air temperature is high. In this case it is advisable to stop the car and switch off the engine for a few minutes, after which the journey can be resumed, preferably at a higher speed.

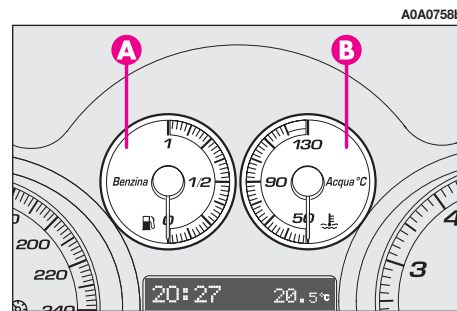

fig. 76

DIGITAL MULTIFUNCTION DISPLAY (where fitted)

The digital multifunction display shows the following: clock, outside temperature, buzzer setting (buzzer on/off), rheostat (light adjustment), condition of the inertial fuel cut-off switch (**FPS on**).

CONTROL BUTTONS (fig. 75)

To make use of the information the digital display (with the ignition key at **MAR**) is able to give, you should firstly familiarise with the control buttons on the plate at the side of the steering column, using them as described in the following paragraphs. Before doing anything at all, you are advised to read this chapter in full.

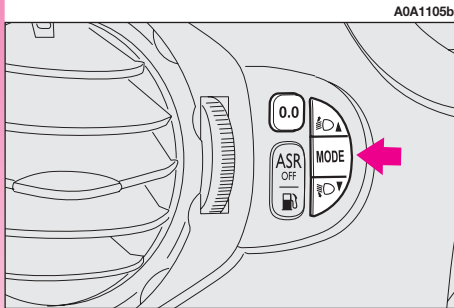
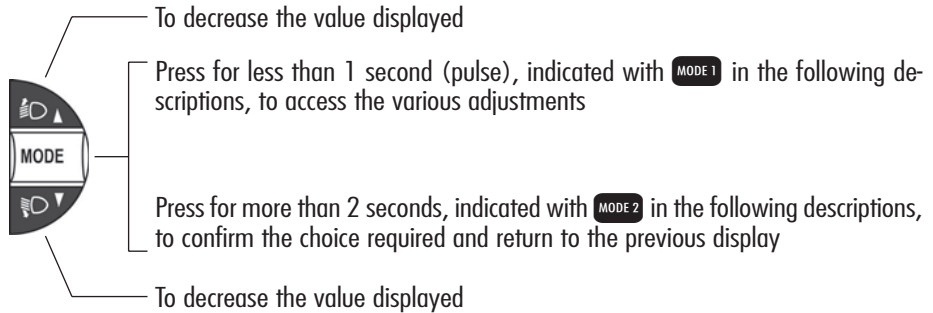

fig. 75



CLOCK (fig. 76)**Adjusting the hours**

Press the MODE button in **MODE 1**, the hours will flash. Set the hour required using buttons ▲ or ▼.

Every press on the button will increase by one unit.

Keeping the button pressed obtains automatic fast increase or decrease.

When you are near the value required, release the control and complete adjustment with single presses.

Then press the MODE button in **MODE 2** to store.

clock and outside temperature display

A0A0009b



fig. 76

Adjusting the minutes

Press the MODE button twice in **MODE 1**, the minutes will flash. Set the minutes required using buttons ▲ or ▼.

Every press on the button will increase by one unit.

Keeping the button pressed obtains automatic fast increase or decrease.

When you are near the value required, release the control and complete adjustment with single presses.

Then press the MODE button in **MODE 2** to store.

OUTSIDE TEMPERATURE (fig. 76)

Outside temperature can be viewed on the display lower side, under the hour indication. When the outside temperature is below or 3°C , the indicator starts flashing together with the buzzer, to warn the driver about the possible presence of ice on the road. The acoustic signal lasts about 2 seconds, while the outside temperature indicator flashes for about 10 seconds. The signal of possible presence of ice on the road is repeated only if the outside temperature is over 6°C and then reaches again 3°C .

BUZZER (fig. 77-78)

The buzzer which accompanies the controls may be activated (**ON**) or deactivated (**OFF**); proceed as follows:

Press the MODE button 3 times in **MODE 1**, then use buttons ▲ or ▼, to turn the buzzer on or off.

Then press the MODE button in **MODE 2** to store the condition chosen.

buzzer activated display (ON)

A0A0083b



fig. 77

LIGHT RHEOSTAT (fig. 79-80)

This function makes it possible to adjust the lighting (dimming/increasing) of the instrument cluster, odometer display (total and trip meter, headlamp aiming device display) of the clock/outside temperature display and of the radio display.

To access the light rheostat, open the menu by pressing button MODE, select "ILLU" (first option displayed) by pressing again button MODE and then set the required level using buttons ▲/▼.

"ILLU" function is available when at least the side/taillights are on.

Partial lighting

Keeping button ▼ pressed (on the plate at the side of the steering column) for more than 4 seconds the instrument cluster light-

buzzer deactivated display (OFF)

A0A0014b



fig. 78

ing is turned off with the exception of the speedometer.

Keeping button ▲ pressed (on the plate at the side of the steering column) for more than 4 seconds the complete instrument cluster lighting is turned on again.

display
with minimum brightness

A0A0012b

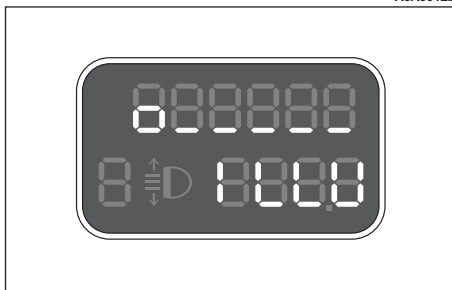

fig. 79

display
with maximum brightness

A0A0013b

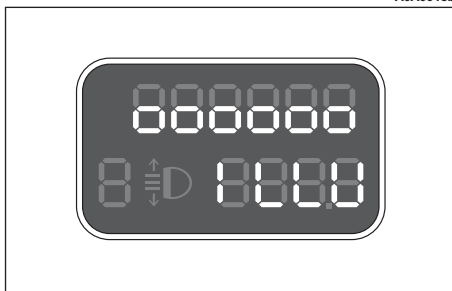

fig. 80

INERTIAL FUEL CUT-OFF SWITCH ON DISPLAY (fig. 81)

The display shown appears automatically when the inertial fuel cut-off switch cuts in, following a crash of a certain magnitude.

The switch shuts off the supply of fuel.

IMPORTANT See the description in the Controls paragraph under the Inertial fuel cut-off switch.

inertial fuel cut-off switch
on display

A0A0007b

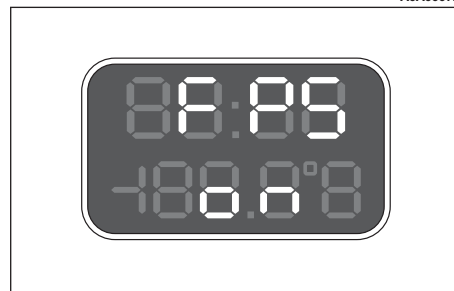

fig. 81

RECONFIGURABLE MULTIFUNCTION DISPLAY

The reconfigurable multifunction display is able to display all the useful and necessary information when driving, in particular:

INFORMATION ON STANDARD SCREEN

- Time (**A**-fig. 82);
- Outside temperature (**B**);
- Date (**C**).

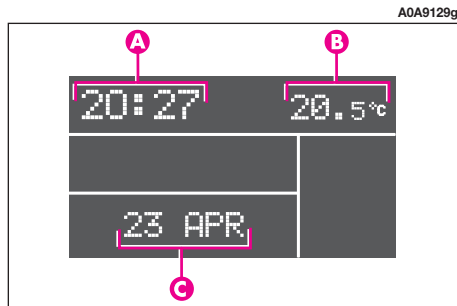

fig. 82

INFORMATION ABOUT CAR CONDITION

- Trip computer;
- Lighting adjustment (rheostat);
- Display of failure messages with corresponding symbol;
- Display of warning messages with corresponding symbol (e.g.: possible ice on road);
- Gear selected (2.0 T.SPARK Selespeed versions only);
- Engine oil level (JTDM versions only).

CONTROL BUTTONS fig. 83

MODE

Press the button briefly: to confirm the selected option and/or to go to next screen;

Press the button for long: to confirm the selected option and to go back to previous screen;

▲/▼ to scroll the "Setup Menu" upwards/downwards or to increase/decrease the value displayed.

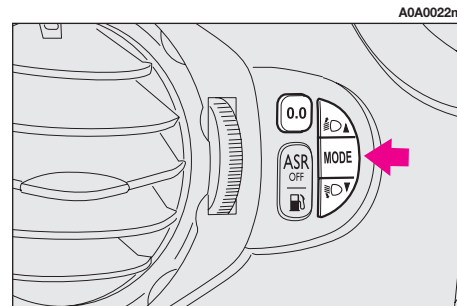

fig. 83

“SETUP MENU”

The “Setup Menu” shall be used to perform the adjustments and/or settings described on the following pages, by pressing button **MODE** and **▲/▼** (see **fig. 83**). Press briefly button **MODE** to display the setup menu. The menu consists of a set of functions arranged in a “circular fashion” **fig. 84**.

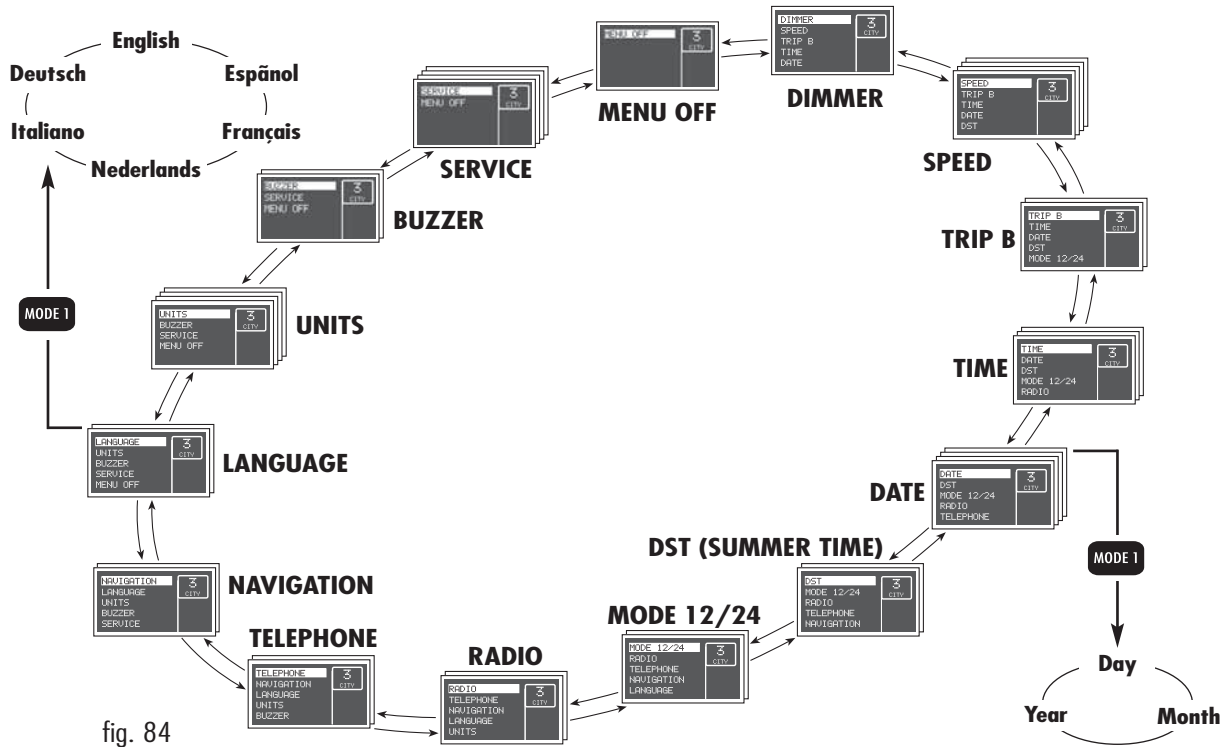

fig. 84

Press briefly button **MODE** to open the menu. To surf the menu, press buttons **▲** or **▼**. For safety reasons, when the car is running, it is possible to access only the reduced menu (for setting “DIMMER” and “SPEED” values). When the car is stationary access to the whole menu is enabled.

Engine oil level check (JTD versions)

Turning the ignition key to **MAR** the display shows the engine oil level for a few seconds. During this phase, to clear the display and move to next screen, press briefly button **MODE**.

IMPORTANT To make sure that the engine oil level displayed is correct, carry out the check with the car on level ground.

Fig. 85 refers to the correct engine oil level display. As the oil level gradually falls, the full bars go off leaving room for the empty ones.

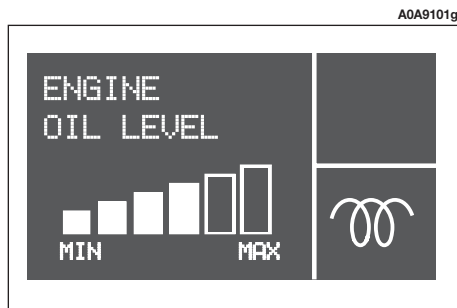

fig. 85

Fig. 86 refers to the display with an oil level below the preset minimum. In this condition the bars are all empty.

IMPORTANT In this case the correct engine oil level should be restored as soon as possible, see "Checking levels" in section "Car maintenance".

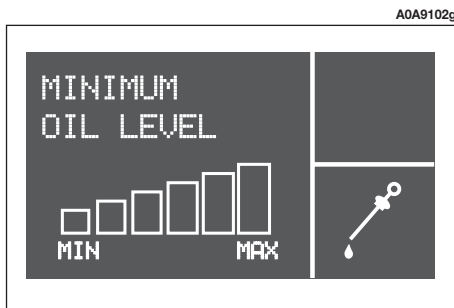

fig. 86

Fig. 87 refers to the display with an oil level above the preset maximum. In this condition the bars are all full.

IMPORTANT In this case, contact Alfa Romeo Authorised Services who will restore the correct engine oil level.

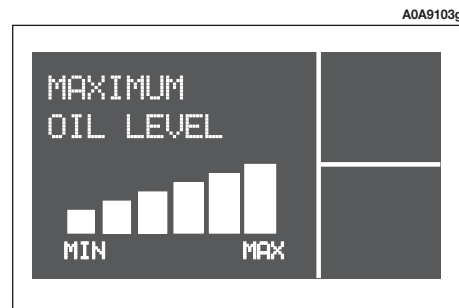

fig. 87

DIMMER

With this function it is possible to adjust the lighting (dimming/brightening) of the instrument cluster, mileage recorder (total, trip meter), headlight aiming display, radio display, radio navigator display (where provided) and two-zone climate control (where provided).

Proceed as follows:

- press briefly button **MODE**: the display will show a graduated scale;
- press buttons ▲/▼ to adjust as required.

Partial lighting

Keeping button (▼) pressed for more than 4 seconds, the rev counter lighting is turned off.

Keeping button (▲) pressed for more than 4 seconds, the complete instrument cluster lighting is turned on again.

IMPORTANT When external lights are switched on dimming of the brightness can be perceived. In the event of any faults, lighting adjustment (rheostat) is not possible and the display is shown at its maximum brightness.

SPEED

With this function it is possible to set the car speed limit (km/h or mph), when this limit is exceeded the driver is immediately alerted (see section “Warning lights and messages”).

To set the speed limit, proceed as follows:

- press briefly button **MODE**: the display will show the word **ON**;
- press briefly button **MODE** then, use buttons ▲/▼ to set the required speed (during setting the value flashes).
- press briefly button **MODE** to go back to the menu screen or press the button for long to go back to the standard screen.

IMPORTANT The possible setting is between 30 and 250 km/h or between 20 and 150 mph depending on the unit set previously (see paragraph “UNITS” described later). Every press of the button ▲/▼ increases or decreases by one unit. Keeping button ▲/▼ pressed, obtain automatic fast increase/decrease. When you are near the required setting release the button and complete adjustment with single presses.

To clear setting:

- press briefly button **MODE**: the display will show the word **OFF**;
- press button (▼): the display will show the word **OFF**;
- press briefly button **MODE** to go back to the menu screen or press the button for long to go back to the standard screen.

TRIP B

With this option it is possible to turn (**ON/OFF**) the TRIP B function (partial trip) which displays the figures relating to AVERAGE CONSUMPTION B, AVERAGE SPEED B, TRAVEL TIME B, and TRAVEL DISTANCE B during a "partial mission" contained in the "general mission" (for further information see "Trip Computer").

For activation/deactivation, proceed as follows:

- press briefly button **MODE**: the display will show the word **ON**;
- use buttons **▲/▼** to select on or off;
- press briefly button **MODE** to go back to the menu screen or press the button for long to go back to the standard screen.

TIME

This function enables to set the clock (hours - minutes).

Proceed as follows:

- press briefly button **MODE**: the display will show the hour;
- press buttons **▲/▼** for setting;
- press briefly button **MODE** to set minutes (pressing the button for long will return to standard screen);
- press buttons **▲/▼** for setting;
- press briefly button **MODE** to go back to the menu screen or press the button for long to go back to the standard screen.

IMPORTANT Every press of the button **▲/▼** increases or decreases by one unit. Keeping button **▲/▼** pressed, obtain automatic fast increase/decrease. When you are near the required setting release the button and complete adjustment with single presses.

DATE

This function enables to update the date (day - month - year).

To correct the date proceed as follows:

- press briefly button **MODE**: the display will show the date;
- press buttons **▲/▼** for setting the day;
- press briefly button **MODE** for setting the month (or press the button for long to go back to standard screen);
- press buttons **▲/▼** for setting;
- press briefly button **MODE** for setting the year (or press the button for long to go back to standard screen);
- press buttons **▲/▼** for setting;
- press briefly button **MODE** to go back to the menu screen or press the button for long to go back to the standard screen.

DST (SUMMER TIME)

This option enables to turn **ON/OFF** the summer time function (which corresponds to + 1 hour in relation to the daylight time).

For activation/deactivation, proceed as follows:

- press briefly button **MODE**: the display will show the word **ON**;
- use buttons **▲/▼** to select on or off;
- press briefly button **MODE** to go back to the menu screen or press the button for long to go back to the standard screen.

Selecting and activating the “**DST ON**” function, the display switches from daylight time to summer time and vice versa, with no need to intervene manually on the “**TIME**” function described previously.

MODE 12/24

This option enables to set the clock in the 12h or 24h mode.

To adjust, proceed as follows:

- press briefly button **MODE**: the display will show **12h**;
- press buttons **▲/▼** for setting (**12h** or **24h**);
- press briefly button **MODE** to go back to the menu screen or press the button for long to go back to the standard screen.

RADIO

This option enables to activate/deactivate (**ON/OFF**) the repetition of the information displayed by the radio front panel on the instrument panel display.

For activation/deactivation, proceed as follows:

- press briefly button **MODE**: the display will show the word **ON**;
- use buttons **▲/▼** to select on or off;
- press briefly button **MODE** to go back to the menu screen or press the button for long to go back to the standard screen.

Selecting and activating “**RADIO DISPLAY ON**”, when turning the radio on, the display repeats the information displayed by the radio front panel.

TELEPHONE

This option enables to activate/deactivate (**ON/OFF**) displaying of the name (if in the list) and phone number of the caller on the instrument panel display.

For activation/deactivation, proceed as follows:

- press briefly button **MODE**: the display will show the word **ON**;
- use buttons **▲/▼** to select on or off;
- press briefly button **MODE** to go back to the menu screen or press the button for long to go back to the standard screen.

Selecting and activating “**TELEPHONE DISPLAY ON**”, when a phone call arrives, the display shows the name (if in the list) and the phone number of the caller.

NAVIGATION

This option enables, during use of the radionavigator, to activate/deactivate (**ON/OFF**) the repetition of the pictograms displayed by the radionavigator on the instrument panel display.

For activation/deactivation, proceed as follows:

- press briefly button **MODE**: the display will show the word **ON**;
- use buttons **▲/▼** to select on or off;
- press briefly button **MODE** to go back to the menu screen or press the button for long to go back to the standard screen.

Selecting and activating “**NAVIGATION DISPLAY ON**”, the instrument panel display shows the information displayed by the radionavigator display.

LANGUAGE

This option enables to select the language required for the texts shown on the display.

To set the required language proceed as follows:

- press briefly button **MODE**: the display will show the previously set “language”;
- press buttons **▲/▼** for setting;
- press briefly button **MODE** to go back to the menu screen or press the button for long to go back to the standard screen.

UNITS

This option enables to set the units for distance covered (km or mi), fuel consumption (l/100 km, km/l or mpg) and temperature (°C or °F).

To set the required unit proceed as follows:

- press briefly button **MODE**: the display will show “**km**” or “**mi**” (according to previous setting);
- press buttons **▲/▼** for setting;
- press briefly button **MODE** to select the temperature unit (or press the button for long to go back to the standard screen): the display will show °**C** or °**F** (according to previous setting);
- press buttons **▲/▼** for setting;

- press briefly button **MODE** to select the consumption unit (or press the button for long to go back to the standard screen);
- If the distance unit set is "**km**", the display will show "**l/100km**" or "**km/l**"; press buttons **▲/▼** for setting. If the distance unit set is "**mi**", the display will show "**mpg**";
- press briefly button **MODE** to go back to the menu screen or press the button for long to go back to the standard screen.

IMPORTANT The temperature unit (**°C** or **°F**) set on the display is also shown on the displays of the two-zone climate control (where provided) and radionavigator (where provided).

BUZZER

This option enables to adjust the volume of the roger-beep accompanying the activation of the car buttons and any failure/warning indication shown on the display.

To adjust the volume proceed as follows:

- press briefly button **MODE**: the display will show the previously set volume "level";
- press buttons **▲/▼** for setting;
- press briefly button **MODE** to go back to the menu screen or press the button for long to go back to the standard screen.

IMPORTANT In the buzzer **OFF** condition, any buzzer failure warnings are maintained.

SERVICE

Through this function it is possible to display information connected to proper car servicing.

To consult this function, proceed as follows:

- press briefly button **MODE**: service in "**km**" or "**mi**" according to previous setting, will be displayed (see paragraph "UNITS");
- press buttons **▲/▼** to display the required service info;
- press briefly button **MODE** to go back to the menu screen or press the button for long to go back to the standard screen.

IMPORTANT The Service Schedule includes car maintenance every 20,000 km; this is shown automatically, with the ignition key to **MAR**, starting from 2,000 km (or mi) from this deadline and it will be displayed again every 200 km. The display can only be reset by Alfa Romeo Authorized Services.

MENU OFF

Selecting this option will bring back to standard screen.

TRIP COMPUTER

General features

The "Trip computer" displays information relating to the operating status of the car. This function comprises the GENERAL TRIP, concerning the "complete mission" of the car (journey) and TRIP B, concerning the partial mission of the car; this latter function (as shown in the following diagram) is "contained" within the complete mission.

Both functions are resettable (reset - start of new mission).

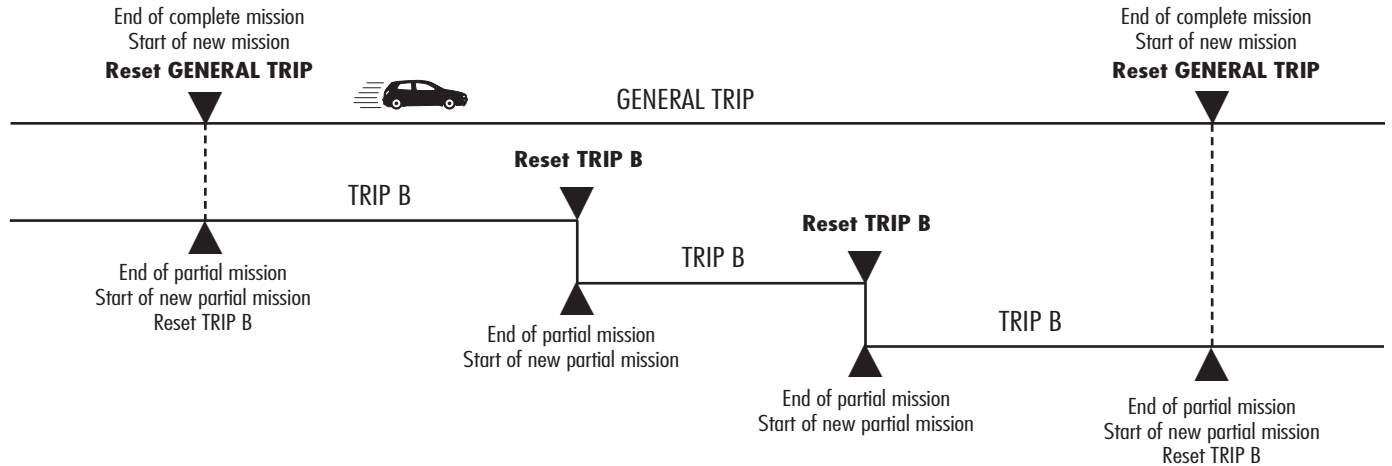

The GENERAL TRIP displays the figures relating to:

- Average consumption
- Actual consumption
- Average speed
- Travel time
- Range
- Travel Distance

TRIP B displays information concerning:

- Average consumption B
- Average speed B
- Travel time B
- Travel Distance B

Values displayed

Average consumption

This value shows the average consumption from the start of the new mission.

Actual consumption

This value shows instant fuel consumption (this value is updated second by second). If parking the car with engine on, the display will show “- - -”.

Average speed

This value shows the car average speed as a function of the overall time elapsed since the start of the new mission.

Travel time

This value shows the time elapsed since the start of the new mission (driving time).

Range

This value shows the distance in km (or mi) that the car can still cover before needing fuel, assuming that driving conditions are kept unvaried.

The display will show “- - -” in the following cases:

- value lower than 50 km (or 30 mi);
- car left parked with engine running for over 5 minutes.

Travel Distance

This value shows the distance covered from the start of the new mission.

Each time the battery is connected and each time a new mission is started (reset), the display will show “0.0”.

IMPORTANT Lacking information, TRIP COMPUTER values are displayed with “- - -”. When normal operating condition is reset, calculation of different units will restart regularly. Values displayed before the failure will not be reset.

New mission (reset)

Reset can be:

- “manual”: reset is performed by the driver by pressing for long button **SET**;
- “automatic”: reset is performed when the “travel distance” reaches 9999.9 km (or mi), when “travel time” reaches 99:59 (99 hours and 59 minutes) or after disconnecting and then reconnecting the battery.

SET BUTTON

This button, set on the right steering column stalk (**fig. 86**), shall be used (with ignition key **MAR**), to enter the GENERAL TRIP and TRIP B functions.

Button **SET** shall also be used to reset the GENERAL TRIP and TRIP B functions to start a new mission:

- **short push**: to go to next screen;
- **long push**: to reset and then start a new mission.

Start of journey procedure (reset)

With ignition key at **MAR**, press and keep button **SET** pressed for over 2 seconds to reset.

The reset operation (button **SET** pressed for over 2 seconds) in the presence of the screens concerning the GENERAL TRIP makes it possible to reset also the TRIP B.

The reset operation (button **SET** pressed for over 2 seconds) in the presence of the screens concerning only the TRIP B makes it possible to reset only the information associated with this function.

IMPORTANT RANGE and ACTUAL CONSUMPTION information cannot be reset.

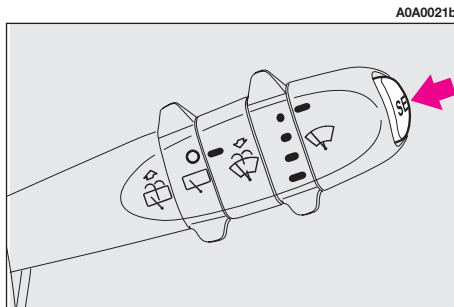

fig. 86

WARNING LIGHTS AND MESSAGES

IMPORTANT The presence of warning lights depends on the type of engine and equipment with which the car is fitted.



LOW BRAKE FLUID LEVEL (red)

HANDBRAKE ON (red)

Turning the ignition key to **MAR** the warning light turns on, but it should go off after few seconds.

Low brake fluid level

The warning light turns on (together with message + symbol on the display) when the level of the brake fluid in the reservoir falls below the minimum level, due to possible leak in the circuit.

Handbrake on

The warning light turns on when the handbrake is on.



If the warning light turns on when travelling, check that the handbrake is not engaged. If the warning light stays on with handbrake disengaged, stop the car immediately and contact Alfa Romeo Authorized Services.



HIGH ENGINE COOLANT TEMPERATURE (red)

Turning the ignition key to **MAR** the warning light turns on, but it should go off after few seconds.

The warning light turns on (together with message + symbol on the display) when the engine is overheated: if the warning light comes on when driving, stop the car leaving the engine on and slightly accelerated to further activate the circulation of the coolant fluid.

If the warning light does not turn off within the next 2 or 3 minutes, stop the engine and contact Alfa Romeo Authorized Services.



AIR BAG FAILURE (red)



Turning the ignition key to **MAR** the warning light turns on, but it should go off after few seconds.

The warning light stays on glowing steadily if there is a failure in the air bag system.



If when turning the ignition key to **MAR**, the warning light  does not turn on or if it stays on when travelling there could be a failure in safety systems; in this event air bags or pretensioners could not trigger in case of impact or, in a minor number of cases, they could trigger accidentally. Before restarting contact Alfa Romeo Authorized Services.



The failure of the warning light  (warning light off) is also indicated by the flashing for more than the normal 4 seconds of the air bag warning light .



LOW ENGINE OIL PRESSURE

Message + symbol are displayed when engine oil pressure is low.



If message + symbol are displayed when travelling stop the engine immediately and contact Alfa Romeo Authorized Services.



LOW BATTERY CHARGE

Message + symbol are displayed when the battery charge is low.

If message + symbol are displayed, contact immediately Alfa Romeo Authorized Services.



SEAT BELTS NOT FASTENED (red)

The warning light turns on glowing steadily with ignition key at **MAR**, when the driver's seat belt is not fastened correctly.



INCOMPLETE DOOR LOCKING

Message + symbol are displayed when one or more doors or the bonnet are not properly shut.



BRAKE PAD WEAR

With the brake pedal pressed, the display will show message + symbol when front brake pads are worn; in this case have them changed as soon as possible.

IMPORTANT Since the car is fitted with wear sensors for the front brake pads, when changing them, check also the rear brake pads.



SELESPEED TRANSMISSION FAILURE (2.0 T.SPARK Selespeed versions)

On versions with Selespeed transmission, message + symbol are displayed when there is a failure in the Selespeed transmission. In the event of Selespeed transmission failure, go as soon as possible to the nearest Alfa Romeo Authorized Services and have the system checked.



ENGINE CONTROL SYSTEM FAILURE (EOBD) (amber)

(upon request for versions/markets where applicable)

In normal conditions, turning the ignition key to **MAR**, the warning light turns on, but it should go off when the engine has started. The initial turning on indicates that the warning light is working properly.

If the warning light stays on or turns on when travelling (together with message + symbol on the display):

glowing steadily - means a fault in the supply/ignition system which could cause high emissions at the exhaust, possible lack of performance, poor handling and high consumption levels. In these conditions it is possible to continue driving without however requiring heavy effort or high speed from the engine. Prolonged use of the car with the warning light on may cause damages. Contact Alfa Romeo Authorized Services as soon as possible. The warning light goes off if the fault disappears, but it is however stored by the system;

flashing - indicates the possibility of damage to the catalyst (see “EOBD system” in this section). If the light flashes, it is necessary to release the accelerator pedal to lower the speed of the engine until the warning light stops flashing; continue the journey at moderate speed, trying to avoid driving conditions that may cause further flashing and contact Alfa Romeo Authorized Services as soon as possible.





If, turning the ignition key to MAR, the warning light does not turn on or if it turns on glowing steadily or flashing when travelling, contact Alfa Romeo Authorized Services as soon as possible.



ALFA ROMEO CODE SYSTEM

Turning the key to **MAR** the symbol on the display shall flash only once and then go off. If with the ignition key at **MAR**, the symbol stays on the display (together with the message), this indicates a possible failure (see “Alfa Romeo CODE system”).

IMPORTANT The turning on at the same time of warning light  and symbol  indicates a failure of the Alfa Romeo CODE system.

If with the engine running, the display shows message + symbol, this means that the car is not protected by the engine immobilising device (see “Alfa Romeo CODE system” in this section). Contact Alfa Romeo Authorized Services to have all the keys memorised.



GLOW PLUG WARMING (diesel versions)

GLOW PLUG WARMING FAILURE (diesel versions)

Glow plug warming

Turning the ignition key to **MAR**, the display shows message + symbol. The symbol will turn off when glow plugs reach the pre-set temperature. Start the engine immediately after the symbol turns off.

IMPORTANT With mild or hot ambient temperature, warning light stays on for very short time.

Glow plug warming failure

Message + symbol are displayed when there is a failure in the glow plug warming system. Contact Alfa Romeo Authorized Services as soon as possible to have the fault eliminated.



WATER IN DIESEL FUEL FILTER (diesel versions)

Message + symbol are displayed when travelling to indicate that there is water in the diesel fuel filter.



The presence of water in the fuel circuit may cause serious damage to the entire injection system and cause irregular engine operation. If message + symbol are displayed on the reconfigurable multifunction display contact Alfa Romeo Authorized Services as soon as possible to have the system relieved. If the above indications come on immediately after refuelling, water has probably been poured into the tank: turn the engine off immediately and contact Alfa Romeo Authorized Services.

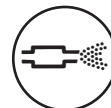

DIESEL PARTICULATE FILTER CLOGGED (diesel versions) (upon request for versions/markets where applicable)

Message + symbol are displayed when the diesel particulate filter is clogged and the driving conditions do not enable to activate automatically the reclaiming procedure.

To enable the cleaning procedure, keep the car running until the message + symbol turn off.



INERTIAL FUEL CUT-OFF SWITCH

Message + symbol are displayed when the inertial fuel cut-off switch is triggered.



If after the message you smell fuel or see leaks from the fuel system, do not reset the switch to avoid fire risk.



INEFFICIENT ABS SYSTEM (where provided) (amber)

Turning the ignition key to **MAR** the warning light turns on, but it should go off after few seconds.



The warning light turns on (together with message + symbol on the display) when the system is inefficient. In this case the braking system keeps its effectiveness unchanged, but without the potential offered by the ABS system.

Caution is advisable, particularly in all cases of less than perfect grip. It is necessary to contact Alfa Romeo Authorized Services as soon as possible.



INEFFICIENT EBD ELECTRONIC BRAKING DISTRIBUTOR (red) (amber)



The turning on at the same time of warning lights  and  (together with message + symbol on the display) with the engine running indicates an EBD system failure; in this case heavy braking may cause the rear wheels to lock before time, with the possibility of skidding.

Drive with the utmost care to the nearest Alfa Romeo Authorized Service to have the system checked.



FRONT PASSENGER'S AIR BAG DEACTIVATED (amber)

(upon request for versions/markets where applicable)

With passenger's front air bags ON, turning the ignition key to **MAR** the warning light turns on, but it should go off after about 4 seconds.

The warning light turns on when the passenger's front Air bag is deactivated.



Warning light  indicates also warning light  failures. This is indicated by intermittent flashing, over 4 seconds, of warning light . In this event warning light  could not indicate safety system failures. Contact Alfa Romeo Authorized Services to have the system checked immediately.



VDC SYSTEM (where provided) (amber)

Turning the ignition key to **MAR** the warning light turns on, but it should go off after few seconds.

If the warning light does not turn off or stays on when travelling (together with message + symbol on the display), contact Alfa Romeo Authorized Services.

The warning light flashes when the VDC system cuts in.



ASR (WHEEL ANTISKID SYSTEM) (where provided) (amber)

Turning the ignition key to **MAR**, the warning light turns on, but it should go off after few seconds.

The warning light turns on when the system is switched off. The warning light flashes when the system cuts in, to alert the driver that the system is adapting to the road surface grip conditions.

The turning on of the warning light (together with message + symbol on the display) also indicates a failure of the ASR system. In this case contact Alfa Romeo Authorized Services as soon as possible.



EXTERNAL LIGHTS FAILURE (amber)

Turning the ignition key to **MAR**, the warning light turns on, but it should go off after few seconds.

The display will show message + symbol when one of the following lights is failing:

- side/taillights
- brake lights and relevant fuse
- rear fog lights
- number plate lights.

The failure referring to these lights could be: one or more blown bulbs, a blown protection fuse or an electric connection cut-off.



FUEL RESERVE (amber)

The warning light turns on (on certain versions with the message on the display) when about 7 litres fuel are left in the tank and, on certain versions when the cruising range is less than 50 km.



LEFT-HAND DIRECTION INDICATOR (green)

The warning light turns on when the direction indicator stalk is moved downwards or, together with the right indicator, when the hazard warning light button is pressed.



RIGHT-HAND DIRECTION INDICATOR (green)

The warning light turns on when the direction indicator stalk is moved upwards or, together with the left indicator, when the hazard warning light button is pressed.



SIDE/TAILLIGHTS (green)

The warning light turns on when side/tail lights or low beams are turned on.



CRUISE CONTROL (where provided) (green)

The warning light turns on (on certain versions with message + symbol on the display) when turning the Cruise Control knurled ring to ON.



MAIN BEAMS (blue)

The warning light turns on when the main beams or the "Follow me home" device are turned on (see the relevant paragraph).



POSSIBLE PRESENCE OF ICE ON THE ROAD

The display shows message + symbol ❄️ and a buzzer will sound when the outside temperature reaches or falls below 3°C to warn the driver of the possible presence of ice on the road.

The buzzer will sound for approx. 2 seconds whereas the message will stay on the display for approx. 10 seconds then, only the symbol will stay displayed until temperature exceeds 6°C or until the engine is switched off.

If when travelling, next to the indication of possible ice on road, the temperature will raise above 6°C symbol ❄️ will turn off. If temperature falls again below 3°C a new message (outside temperature flashing) + symbol ❄️ will be displayed together with the sound of the buzzer.

WARNING LIGHTS FAILURE

The message will be displayed when one of the following warning lights is failing: ABS warning light, EBD warning light, ASR warning light, VDC warning light.

ENGINE OIL LEVEL SENSOR

The warning light turns on when a fault is detected to the engine oil level sensor. Contact Alfa Romeo Authorized Services as soon as possible to have the failure eliminated.

SPEED LIMIT EXCEEDED

The display will show the dedicated message + symbol and the buzzer will sound when the car exceeds the speed limit set previously (see "Reconfigurable multifunction display").

RANGE (Trip Computer)

The display will show the dedicated message + symbol when the cruising range is less than 50 km.

SCHEDULED SERVICING

The display will show the dedicated message starting from 2000 km from the deadline planned in the Service Schedule. The message will be repeated every 200 km when turning the ignition key to **MAR**.

HEATING AND CLIMATE CONTROL SYSTEM

A0A0703b

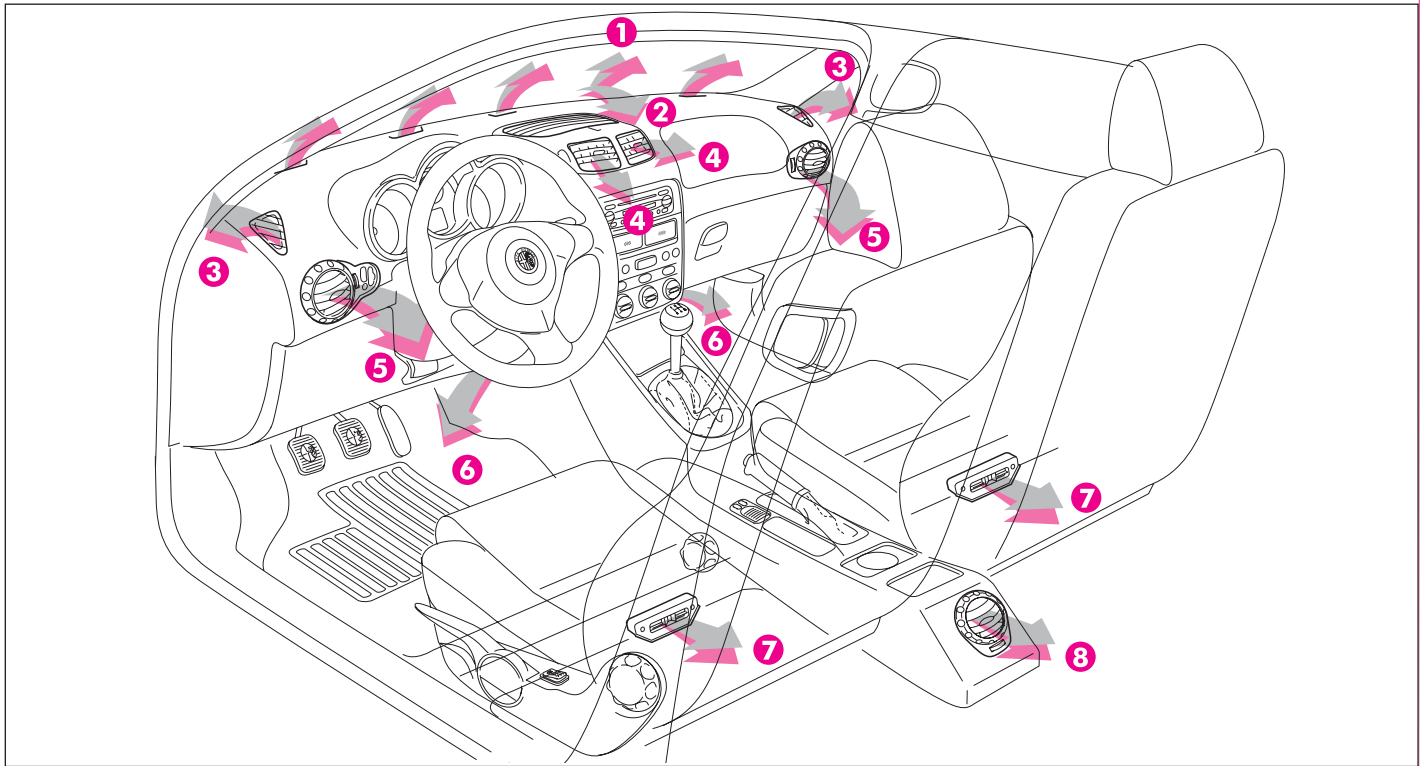

fig. 87

1 Upper stationary vent for defrosting or demisting windscreen - **2** Upper centre adjustable vent - **3** Stationary vents for defrosting or demisting side windows - **4** Adjustable centre, swivel vents - **5** Side adjustable and swivel outlets - **6** Front feet area fixed vents - **7** Rear feet area fixed vents - **8** Rear adjustable swivel outlet.

UPPER CENTRE VENT ADJUSTMENT (fig. 88)

The vent (1) has an opening/closing control (A).

- = Completely closed.
- I = Completely open.

CENTRE SWIVEL VENT ADJUSTMENT (fig. 88)

Each vent (2) has a lever (B) which makes it possible to direct the flow of air (in the 4 directions: up/down, right/left).

To adjust the air flow, use control (C):

- = Completely closed.
- I = Completely open.

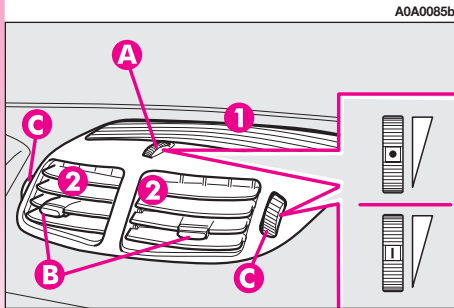

fig. 88

SIDE SWIVEL OUTLET ADJUSTMENT (fig. 89)

To direct the flow of air, turn the knurled ring (A) and/or directly use control (B) as required.

To adjust the air flow, use control (C):

- = Completely closed.
- I = Partially open.
- II = Completely open.

D - fixed vent for defrosting or demisting side windows.

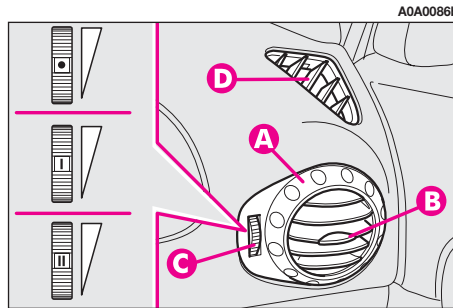

fig. 89

REAR SWIVEL OUTLET ADJUSTMENT (fig. 90)

To direct the flow of air, turn the knurled ring (A) and/or directly use control (B) as required.

To adjust the air flow, use control (C):

- = Completely closed.
- I = Partially open.
- II = Completely open.

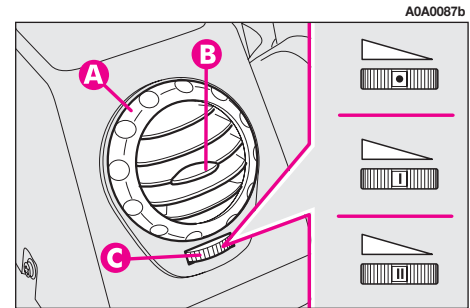

fig. 90

MANUAL CLIMATE CONTROL SYSTEM

Below is a brief description of the climate control system functions.

To obtain them, set the pointer on the rings of the corresponding knobs as illustrated.

For more detailed information about the system and how to make the best use of it, read the instructions given in the following pages.

QUICK DEMISTING/DEFROSTING

A0A0730b

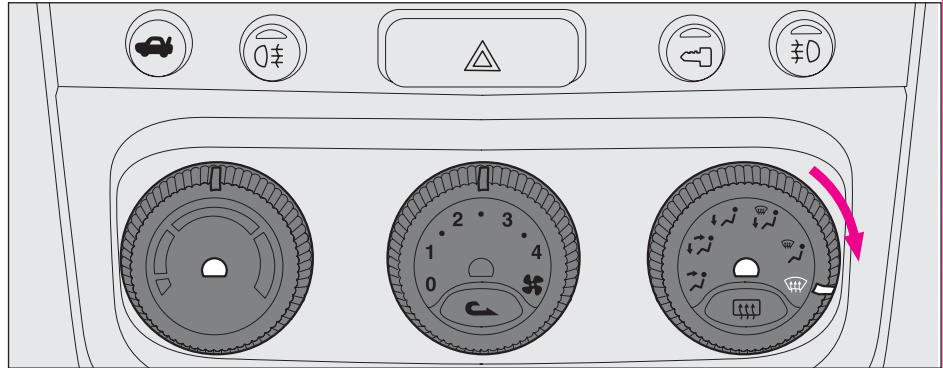

fig. 91

MAXIMUM HEATING POWER

A0A0731b

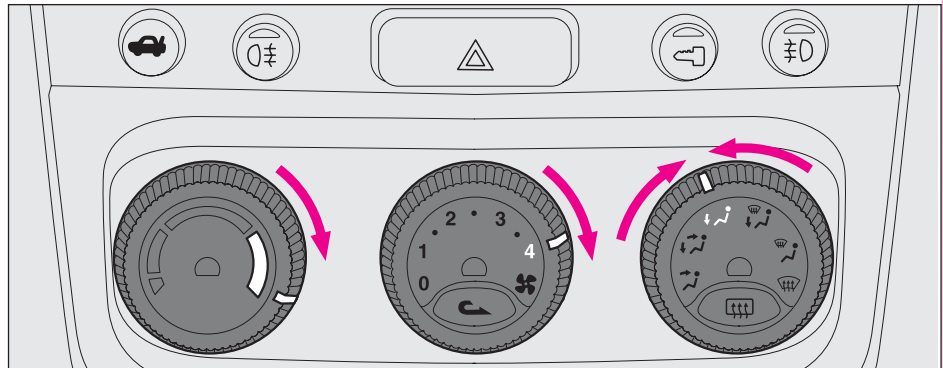



fig. 92

CONTROLS (fig. 93)

- 1 - Air temperature adjustment knob
- 2 - Fan speed adjustment knob
- 3 - Air distribution selector knob
- 4 - Air recirculation on/off button 
- 5 - Rearscreen heating on/off button 

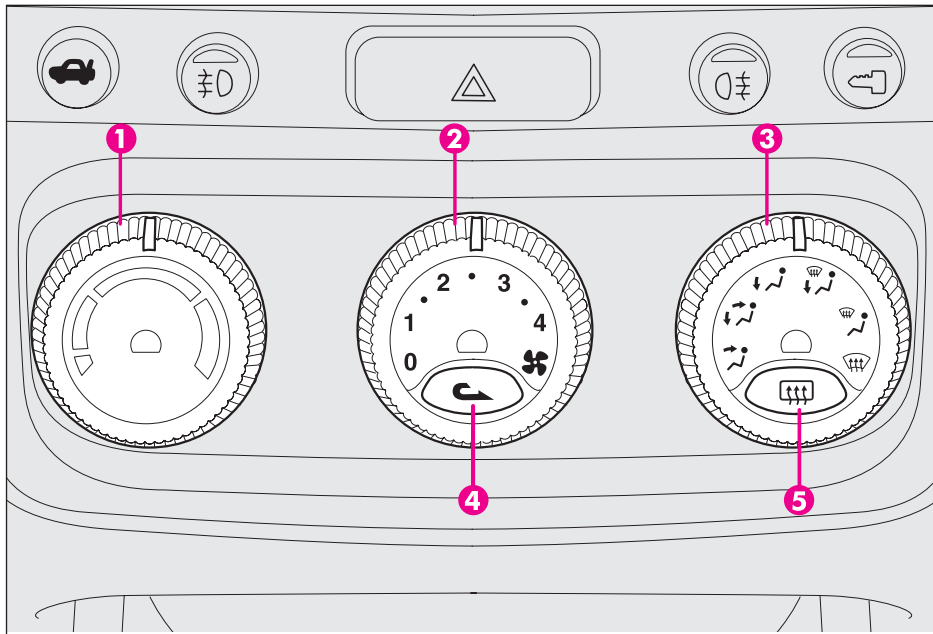



fig. 93

AIR TEMPERATURE ADJUSTMENT KNOB

Turn the ring of knob (**1-fig. 93**) clockwise or counter-clockwise respectively to higher or lower the temperature of the air admitted to the passenger compartment.

FAN SPEED ADJUSTMENT KNOB



Turning the ring of knob (**2-fig. 93**) it is possible to select one of the fan speeds to personalise the amount of air admitted to the passenger compartment.

Position **0** turns off the fan and automatically engages inside air re-circulation (shown by the lighting up of the led next to the button **4** ) thereby shutting off the inlet of outside air to the car.

To switch off inside air re-circulation, press button (**4**) .

AIR DISTRIBUTION KNOB

Turning the knob ring (**3-fig. 93**), the following positions are selected in sequence:

-  Air flow towards the upper centre, front centre vents and from the front and rear outlets with the possibility of adjustment using the controls on the actual vents.
-  Splitting of air flow between the previous vents and the lower part of the passenger compartment.
-  Air flow to the lower part of the passenger compartment (front and rear).

 Splitting of air flow between the windscreen/front side windows and the lower part of the passenger compartment.

 Air flow towards the windscreen and front side windows for demisting/defrosting.

 Flow of air to allow quick demisting/defrosting of the windscreen and front side windows, turning on rearscreen heating for demisting/defrosting (function called **MAX-DEF**).

INSIDE AIR RE-CIRCULATION ON/OFF BUTTON

Pressing button (4-fig. 93)  activates inside air re-circulation and the led next to the button lights up.

In this case the climate control system directly treats the air contained in the passenger compartment, the fan is on.

To switch the air re-circulation feature off and withdraw air from outside, press the button again.



The inside air recirculation system makes it possible to reach the required "heating" or "cooling" conditions faster. It is however inadvisable to use it on rainy/cold days as it would considerably increase the possibility of the windows misting inside, especially if the manual climate control system is off.



It is advisable to turn on the inside air recirculation system  in queues or tunnels to avoid admitting polluted air from outside. The prolonged use of this function should however be avoided, especially with several persons on board, to avoid the possibility of the windows misting inside.

REARSCREEN HEATING ON/OFFBUTTON

Pressing button (5-fig. 93)  turns on demisting/defrosting of the rearscreen, and if present, the door mirrors heating coils; simultaneously the led next to the button turns on. This function is timed and switches off automatically after 20 minutes. To turn off earlier, press the button again.

IMPORTANT The system automatically turns on rearscreen heating if the temperature is below 3°C.

IMPORTANT Do not apply stickers on the inside of the rearscreen over the heating filaments to avoid damage which might cause it to stop working properly.



When cleaning the inside of the rearscreen, take care not to damage the heating filaments.

DEMISTING AND/OR DEFROSTING THE WINDSCREEN AND FRONT SIDE WINDOWS, REARSCREEN AND WING MIRRORS (MAX-DEF FUNCTION) (fig. 94)

Proceed as follows:

- turn the ring of the air distribution knob (3) to the  symbol.

The climate control activates all the functions necessary to quicken demisting/defrosting of the windscreen and side windows with timing (switching off automatically after 3 minutes), as follows:

- switches off air re-circulation, if engaged;
- sets the maximum air temperature;
- operates the fan at a predefined speed;
- directs the flow of air towards the windscreen and front side window vents;
- turns on rearscreen heating and, if present, the wing mirror coils.

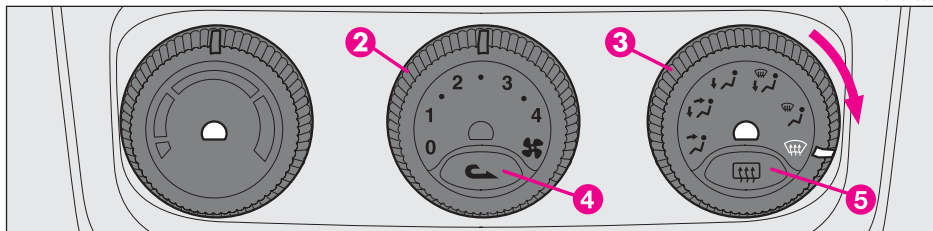



fig. 94



When the max demisting/defrosting function is on, the led next to the rearscreen heating button (5)  will turn on.

IMPORTANT If the engine is not hot enough, the function does not immediately engage the pre-established fan speed, to restrict the inlet of air to the passenger compartment that is not warm enough to demist the windows.

After demisting/defrosting, simply use the controls to maintain the optimum conditions of vision and comfort.

IMPORTANT The hotter the engine the more effective defrosting will be.

IMPORTANT In cases of heavy damp and/or rain and/or big differences in temperature between inside the car and outside, it is advisable to proceed as follows to demist the windows:

- air re-circulation off, led next to button (4)  off;
- pointer of knob (2) at fan second speed at least;
- pointer of knob (3) on symbol  with the possibility of passing to position  if more misting is noted;

To defrost/demist the rearscreen, press button (5) , led next to button on.

HEATING (fig. 95)

To obtain the temperature required, proceed as follows:

- temperature adjustment knob pointer (1) on the red sector as required;
- air quantity adjustment knob pointer (2) on the fan speed required to personalise the amount of air admitted;
- air distribution knob pointer (3) on the required position.

To obtain the maximum heating power proceed as follows:

- knob pointer (1) as far as it will go clockwise (maximum temperature red sector);
- knob pointer (2) on maximum fan speed;
- air distribution knob pointer (3) on the required position (position ✓) is recommended.

IMPORTANT To be able to obtain satisfactory passenger compartment warming, the engine should have reached normal operating temperature.

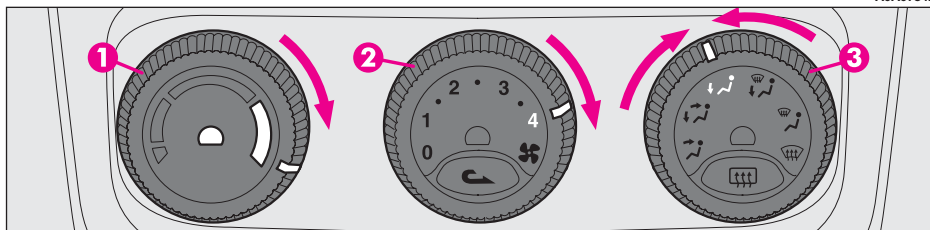

fig. 95

POLLEN FILTER (for versions/markets where applicable)

The filter has the specific capability of filtering external air, thus admitting to the passenger compartment purified air, free from particles such as dust, pollen, etc.

In addition to the above mentioned functions, it also reduces the concentration of pollutants.

The filtering action is active in all air inlet conditions and it is clearly more effective with the windows closed.

Have the conditions of the filter checked at least once a year, preferably at the onset of summer by Alfa Romeo Authorised Services.

If the car is habitually used in dusty or polluted areas, the filter should be checked and replaced at shorter intervals than those specified in the Programmed Maintenance Schedule.



If the filter is not replaced the efficiency of the climate control system may be seriously compromised up to blocking the air flow at the outlets and vents.

AUTOMATIC TWO-ZONE CLIMATE CONTROL SYSTEM

(for versions/markets where applicable)

To start the system (fig. 96):

- turn the knob rings to set the required temperatures (driver's side - passenger's side).

- press the **AUTO** button.

IMPORTANT The climate control system makes it possible to personalise the temperatures required on the two side with a maximum difference of 7°C between the driver's side and the passenger's side.

IMPORTANT The climate control compressor can only work with the engine running and external temperature not very low.

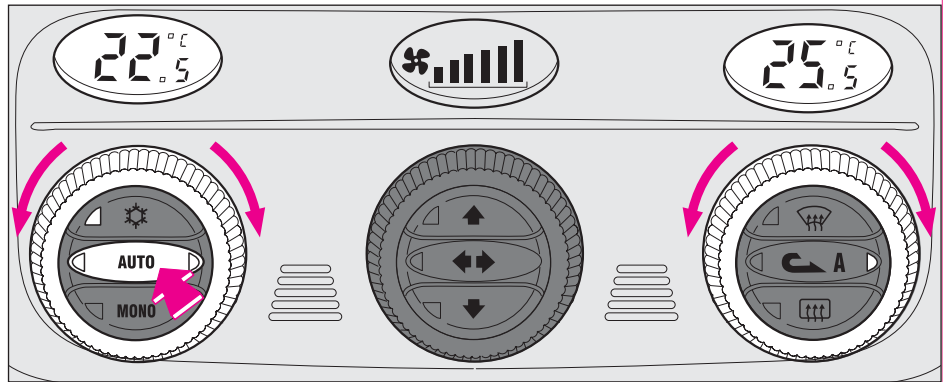

fig. 96



With low external temperature the climate control compressor is unable to work. It is therefore inadvisable to use the inside air recirculation function with low outside temperature as windows may mist over quickly.



The coolant used for the climate control system is R134a which meets current regulations and does not harm the environment in the event of accidental spillage.

Absolutely avoid the use of other fluids which are incompatible with the system components.

GENERAL

The car is fitted with a two-zone climate control system, controlled by an electronic control unit which makes it possible to separately adjust the air temperature on the driver's side and on the passenger's side. To obtain optimum temperature control in the two areas of the passenger compartment, the system has an outside sensor, a passenger compartment sensor and a two-zone sun ray sensor.

On some versions the system is integrated with an incipient misting sensor installed behind the inside rear-view mirror, capable of "controlling" a predefined area of the windscreen inner surface which can automatically act on the system to prevent or reduce misting through a series of operations such as: opening air re-circulation, enabling the compressor, air flow to the windscreen, fan speed sufficient for demisting; in the case of heavy misting, enabling the **MAXDEF** function.



To ensure correct operation of the incipient misting sensor, stickers must not be applied (road licence holder, time card etc.). Care should also be given to cleaning the windscreen and the actual sensor, avoiding the accumulation of dust and other substances.

IMPORTANT The demisting procedure is enabled each time the ignition key is turned to **MAR** or pressing the button **AUTO**. When this procedure is working it can be turned off pressing one of the following buttons : compressor, air recirculation, air distribution, air flow. This operation inhibits the incipient misting sensor signal until the button **AUTO** is pressed again or the next time the ignition key is turned to **MAR**.

On certain versions, the system is integrated by an antipollution sensor capable of automatically switching on inside air recirculation to lessen the harmful effects of polluted air in cities, queues, tunnels and operation of the windscreen washer (with the typical smell of spirits).

IMPORTANT The function of the antipollution sensor is subordinate to safety conditions; therefore disabling the climate control compressor or with low external temperature, the sensor is disabled. In any case, the sensor can be re-enabled pressing the recirculation button  until taking it to the automatic mode.

The air quality control is also entrusted to a combined particle and activated carbon filter. The climate control system automatically controls and adjusts the following parameters and functions:

- temperature of the air admitted to the passenger compartment (for the driver's and passenger's side separately)
- fan speed
- air distribution
- inside air re-circulation on/off
- climate control compressor on/off.

The settings of the following functions can be modified manually:

- fan speed
- air distribution
- inside air re-circulation on/off
- climate control compressor on/off enable.

The control of the functions that have not been modified manually will always be automatic and, in any case, the temperature of the air flowing into the passenger compartment is controlled automatically depending on the temperatures set on the driver's and passenger's displays.

IMPORTANT Manual selections prevail over automatic ones and remain in storage until the user decides to resume automatic control. The settings selected manually are stored when the engine is switched off and resumed the next time it is started.

CONTROLS (fig. 97)

1 - Inside temperature set display (driver's side)

2 - Inside temperature adjustment knob (driver's side)

3 - Fan speed set and system off display (OFF)

4 - Knob for adjusting the fan speed and switching the system off

5 - Inside temperature set display (passenger's side)

6 - Inside temperature adjustment knob (passenger's side)

7 - Maximum defrosting/demisting on/off button for windscreen and front side windows, rearscreen heating and wing mirror coils (**MAX-DEF** function)

8 - Inside air re-circulation on/off button  (manual/automatic)

9 - Rearscreen heating and wing mirror defrosting on/off button 

10 - Air distribution selection buttons

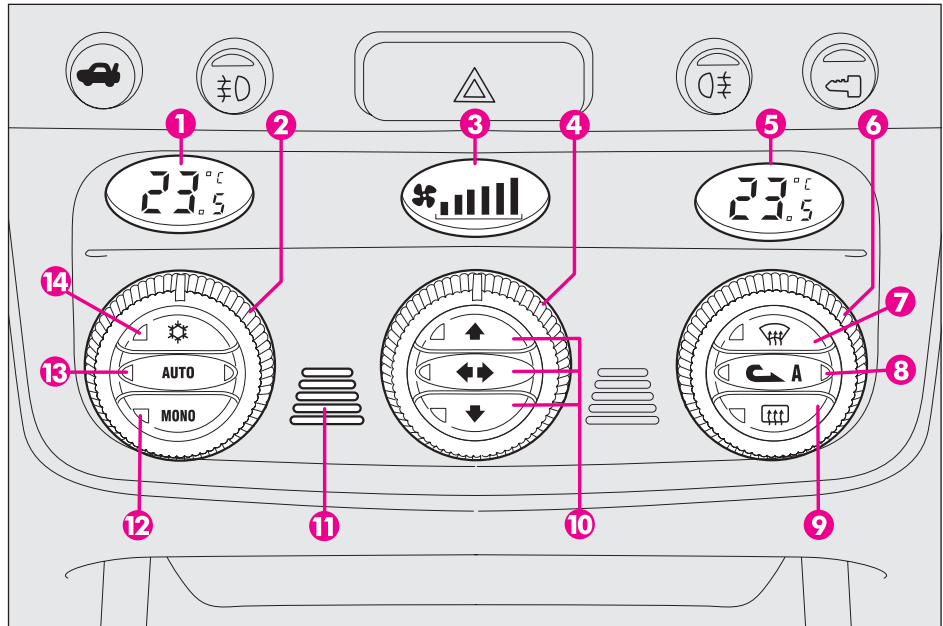



fig. 97

11 - Inside air temperature sensor

12 - Button for aligning the temperature set on the passenger's side with that on the driver's side **MONO**

13 - Button for selecting the system automatic mode **AUTO**

14 - Climate control compressor on/off enable button 

HOW TO USE THE AUTOMATIC TWO-ZONE CLIMATE CONTROL SYSTEM (fig. 97)

IMPORTANT The knob rings do not have a mechanical stopper therefore, once the maximum or minimum value has been reached, they are free to turn in both directions.



The system can be started in different ways, but it is advisable to set the temperatures required on the displays; then press the **(13) AUTO** button.

This way the system will start working completely automatically to reach the temperatures set as quickly as possible and then maintain them.

During completely automatic system operation, the temperatures set can be changed at any time; the system will automatically change its settings to adjust to the new requirements.

IMPORTANT To be able to be accepted by the system, the difference in the temperature between the driver's and passenger's side must be within a range of 7°C.

It is possible to personalise the choices made automatically by the system intervening manually on the following controls:

- fan speed adjustment knob **(4)**
- air distribution selection buttons **(10)**
- inside air re-circulation on/off button **(8)** 
- climate control on enable button **(14)** 

Manually selecting one or more of these functions turns off the right led on the button **(13) AUTO**.

With one or more functions engaged manually, the adjustment of the temperature of the air admitted to the passenger compartment continues to be controlled automatically by the system (left led on button **13 AUTO** on) except with the climate control compressor off.

In fact, in this condition the air admitted to the passenger compartment cannot have a lower temperature than the outside air; this condition is indicated by the turning off of the two leds on button **(13) AUTO** and flashing on the display **(1)** and/or **(5)** related with the temperature rate that cannot be obtained.

AIR TEMPERATURE ADJUSTMENT KNOBS (fig. 98)

Turning the rings of knobs **(2 or 6)**, clockwise or counter-clockwise, respectively higher or lowers the temperature of the air required respectively in the left zone (knob **2**) or right zone (knob **6**) of the passenger compartment. The temperatures set are shown on the displays **(1)** and **(5)** above the knobs.

Separate operation of the temperatures set is restored automatically using knob **(6)**.

Turning the knob rings clockwise or counter-clockwise until they reach the extreme selections **HI** or **LO**, the maximum heating or cooling functions are respectively engaged:

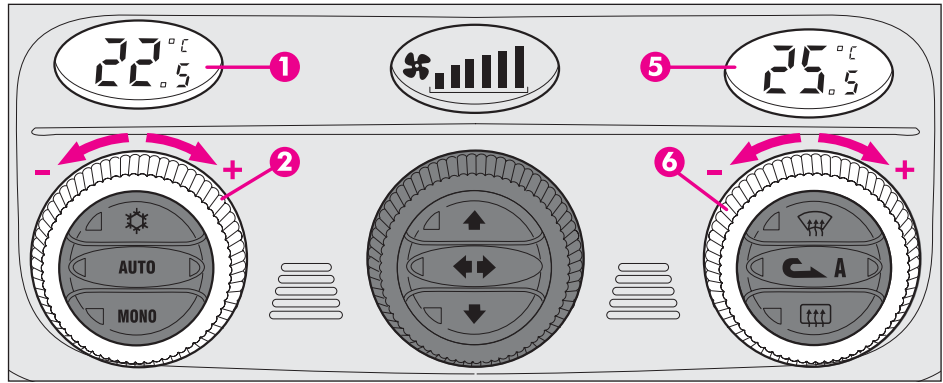

fig. 98

HI function (highest heating power - fig. 99)

This is turned on setting on the display a temperature above 32.5°C, and can be activated independently from the driver's or passenger's side or both; this setting brings the system to the "monozone" mode and is shown on both displays.

This function can be engaged when requiring to heat the passenger compartment as quickly as possible, exploiting the maximum potential of the system.

This function uses the maximum temperature of the coolant fluid, while air distribution and fan speed are controlled according to the system settings.

This function is inadvisable with the engine cold to prevent admitting air that is not warm enough to the passenger compartment.

All manual settings are possible with this function on.

To switch the system off, simply turn the ring of knob (2) or (6) of the temperature set to a value below 32.5°C; the opposite display will show 32.5°C.

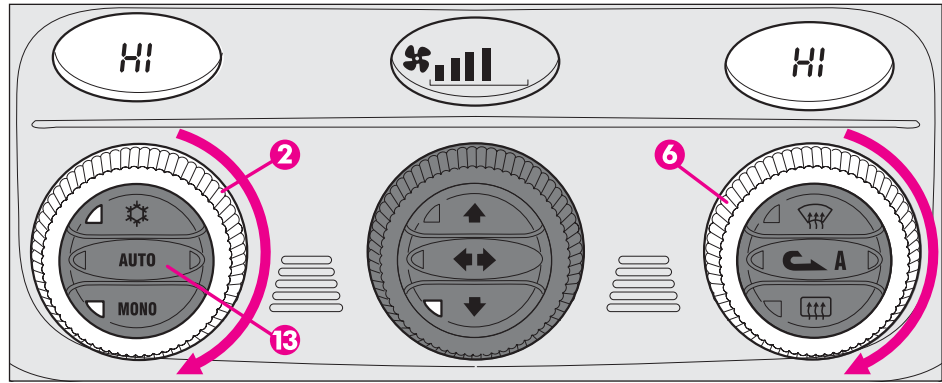

fig. 99

Pressing key (13) **AUTO** the display will show a temperature of 32.5°C and returns to an operating condition with automatic temperature adjustment.

LO function (highest cooling power - fig. 100)

This is turned on setting on the display a temperature below 16.5°C; this setting is shown on both displays.

This function can be engaged when requiring to cool the passenger compartment as quickly as possible, exploiting the maximum potential of the system.

The function cuts off air heating, engages inside air re-circulation (to prevent admitting hot air to the passenger compartment) and the climate control compressor, takes air distribution to $\leftarrow \rightarrow$ and the fan speed as set by the system.

All manual settings are possible with this function on.

To switch the function off, simply turn the ring of knob (2) or (6) of the temperature set on a value above 16.5°C; the opposite display will show 16.5°C.

Pressing key (13) **AUTO** the display will show a temperature of 16.5°C and returns to an operating condition with automatic temperature adjustment.

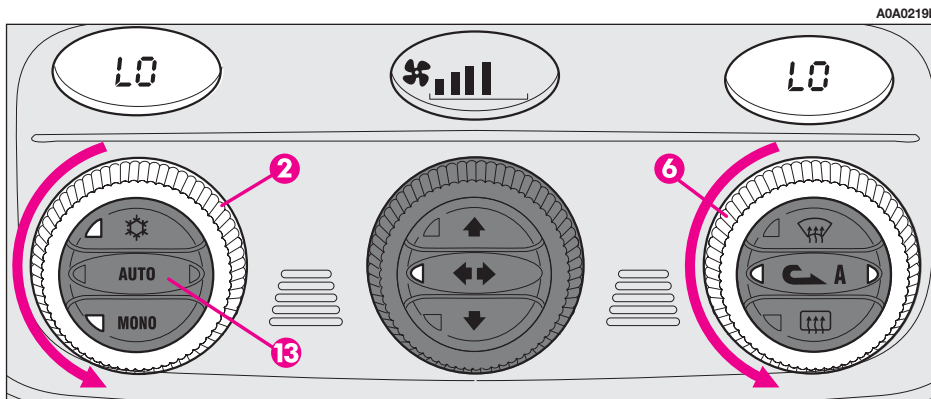

fig. 100

MONO BUTTON FOR ALIGNMENT OF THE TEMPERATURE SET (fig. 101)

Pressing button **(12) MONO** automatically aligns the temperature on the passenger's side with that on the driver's side, therefore it is possible to set the same temperature between the two zones simply turning the ring of knob **(2)** on the driver's side.

This function is provided to simplify temperature adjustment of the whole passenger compartment when only the driver is on board.

Separate operation of the temperatures set is automatically restored when the passenger uses the ring on knob **(6)** or presses button **(12) MONO**.

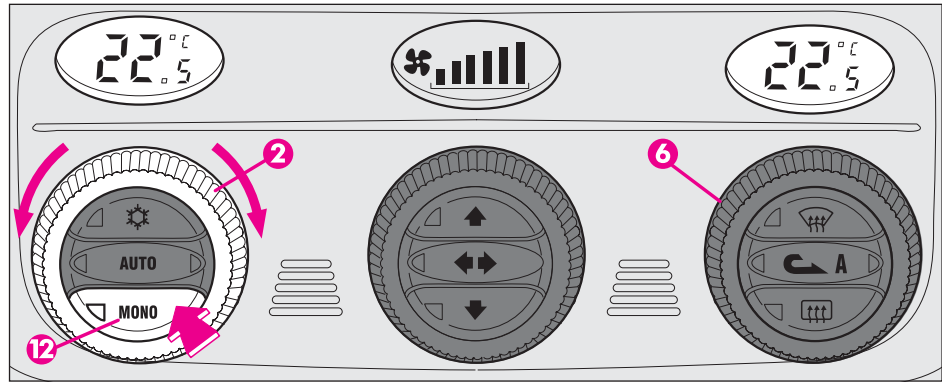



fig. 101

FAN SPEED ADJUSTMENT KNOB (fig. 102-103)

Turning the ring of knob (4), clockwise or counter-clockwise, increases or decreases the speed of the fan, thus the amount of air admitted to the passenger compartment; the 16 selectable speeds are shown on a bar (in steps of 3), up to a maximum of 6 bars lit:

- maximum fan speed = all bars lit;
- minimum fan speed = one bar lit.

The fan can be cut off (all bars off) only if the climate control compressor has been switched off pressing button (14) ☀. To restore automatic fan speed control, after a manual adjustment, press button (13) **AUTO**. Completely turning the ring of knob (4) counter-clockwise switches the system off, with the following situation: display (1) off; display (5) off; centre display (3) with litdisplay **OFF** and left led on inside air re-circulation button (8)  on.

IMPORTANT Pressing the inside air recirculation button (8)  it is possible to obtain the inlet of untreated outside air to the passenger compartment.

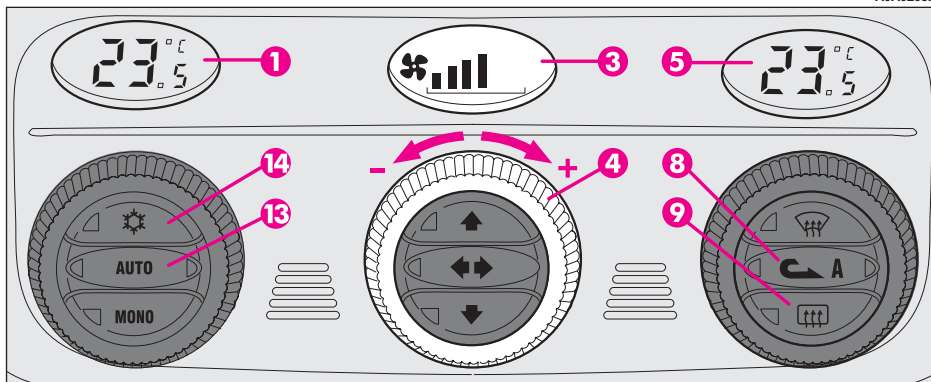

fig. 102

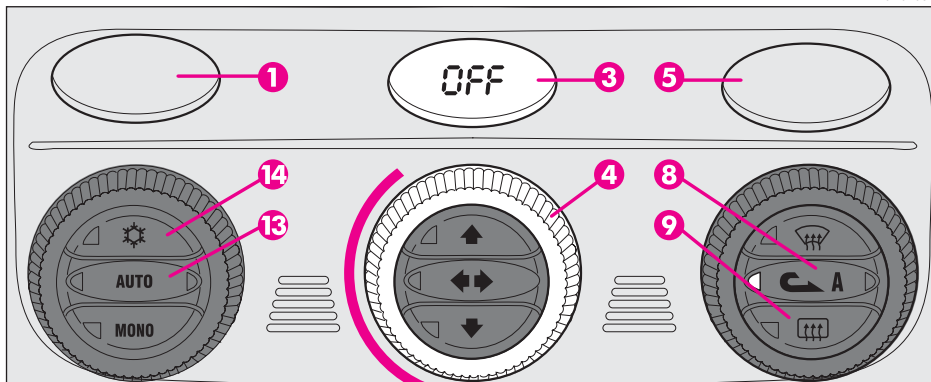



fig. 103

To turn the system on again, simply turn the ring of knob (4) clockwise, or press any one button, except the inside air recirculation (8) and rearscreen (9) buttons; this operation restores all the operating conditions stored previously.

IMPORTANT On leaving the **OFF** condition, inside air re-circulation  returns to the condition prior to switching off.

AIR DISTRIBUTION SELECTION BUTTONS (fig. 104)

Pressing one or more buttons (**10**) it is possible to manually choose one of the 5 possible air distributions to the passenger compartment:

- ↔ Flow of air to the dashboard centre and side outlets and rear outlet.
- ↕ Splitting of the air flow between the vents to the lower part of the passenger compartment (warmest air) and the dashboard centre and side outlets and the rear outlet (coolest air). The air flow distribution is particularly useful in spring and autumn, when the sun is shining.
- ↓ Air flow towards the front and rear lower parts of the passenger compartment. Due to the natural tendency of heat to spread upwards, this type of distribution allows heating of the passenger compartment in the shortest time, also giving a prompt feeling of warmth to the coldest parts of the body.

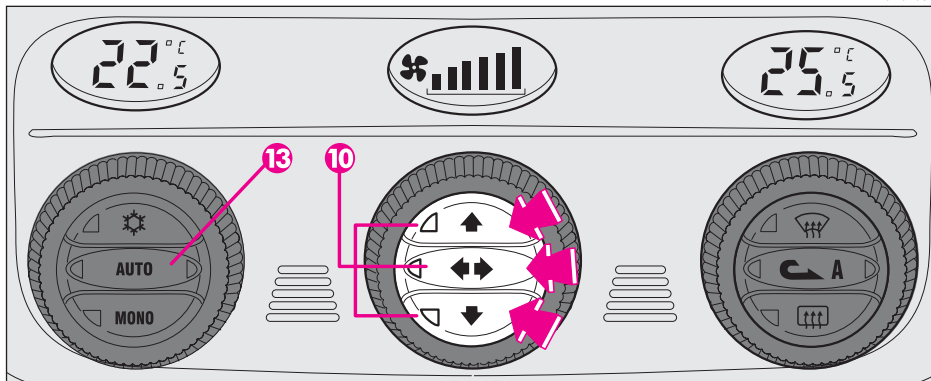

fig. 104

- ↑ Splitting of the air flow between the windscreen and side window defrosting/demisting vents and the lower part the of the car. This type of air distribution allows satisfactory heating of the passenger compartment while preventing misting of the windows.
- ↓
- ↑ Air flow to the windscreen and front side window vents to demist or defrost them.

IMPORTANT Pressing one of these buttons turns on (led on button itself on) or off (led on button off) the associated functions if the combination chosen is among the 5 possible ones; if not it only activates the main function of the button pressed, without the possibility of turning off with another press (at least in one distribution the air flow should be spread in the passenger compartment).

To restore automatic air distribution control after a manual selection, press button (**13**) **AUTO**.

CLIMATE CONTROL COMPRESSOR ON/OFF ENABLE BUTTON (fig. 105)

Pressing button (14) ☀️ enables the turning on of the climate control compressor. This condition is shown by the lighting up of the led on the button itself.

When the climate control compressor is turned off, the leds on buttons (13) **AUTO** and (14) ☀️ go off; automatic inside air re-circulation control is also excluded (both leds off on button 8 🔄) which always stays off to prevent misting the windows; even if unadvisable, it is still possible to restore automatic operation of inside air re-circulation pressing button (8) 🔄.

With the climate control compressor off, it is not possible to admit air to the passenger compartment with a temperature below the outside temperature; in this case, the value flashes on the display concerning the temperature that cannot be reached and the left led on button (13) **AUTO** - fig. 106) goes off.

The switching off of the climate control compressor remains in storage even when the engine has been stopped. To restore automatic control for switching on the climate control compressor, press button (14) ☀️ again, the led on the button

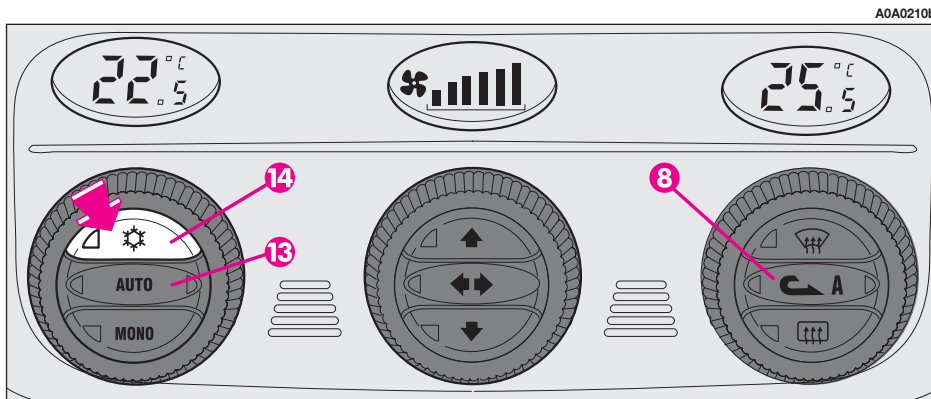

fig. 105

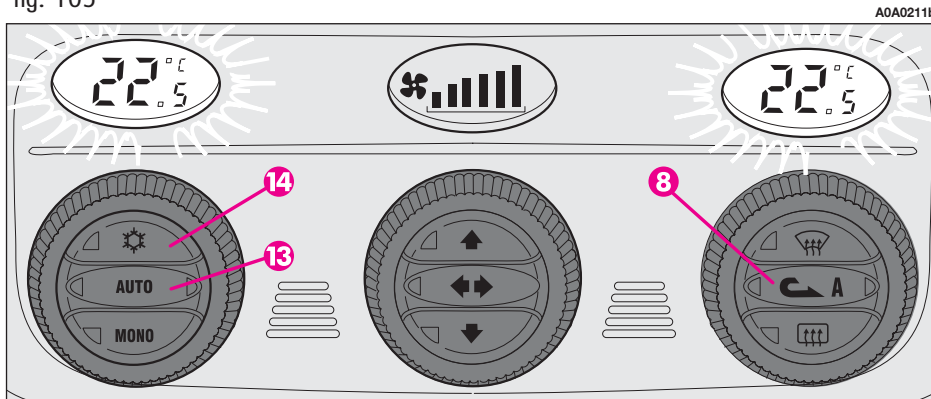

fig. 106

turns on, or press button (13) **AUTO**; in which case, however, the other manual settings set will be cancelled.





Operation of the climate control compressor is necessary for cooling and dehumidifying the air; it is advisable to keep this function always on, to prevent window misting problems.

INSIDE AIR RE-CIRCULATION ON/OFF BUTTON (fig. 107)

Inside air re-circulation is controlled according to three operating logics:

- automatic control, indicated by the turning on of the right led on the button;
- forced engagement (inside air re-circulation always on), indicated by the turning on of the left led on the button (and by the right led going off at the same time);
- forced switching off (inside air re-circulation always off with air inlet from outside), indicated by the turning off of both leds.

These operating conditions are obtained pressing in sequence the inside air re-circulation button (8) .

When inside air re-circulation is controlled automatically by the system, the right led on the air re-circulation button (8)  stays on all the time and the left led shows the air re-circulation condition:

on = air re-circulation operating;

off = air re-circulation off.

If inside air re-circulation has been turned on or off manually, the led on button (13) **AUTO** turns off.

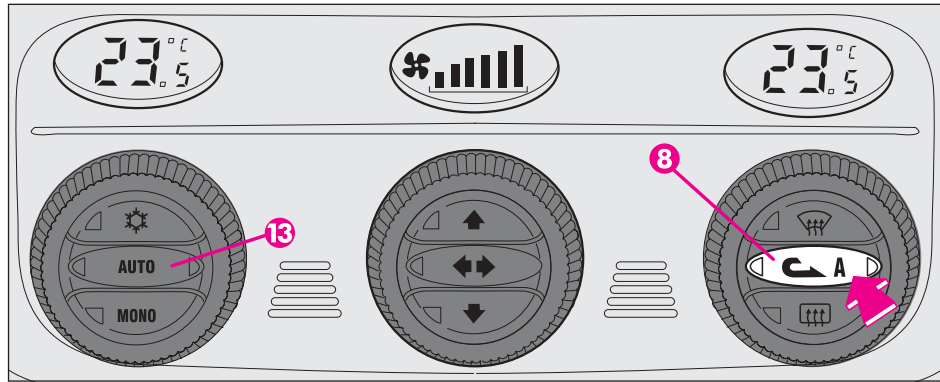



fig. 107

In automatic operation, inside air re-circulation is turned automatically when the antipollution sensor detects the presence of polluted air, for example in cities, queues, tunnels and operation of the windscreen washer (with the typical smell of spirits).



With low external temperature the climate control compressor is unable to work. It is therefore inadvisable to use the inside air recirculation function  with low outside temperature as windows may mist over quickly.



The inside air-re-circulation system makes it possible to reach the required "heating" or "cooling" conditions faster. It is however inadvisable to use it on rainy/cold days as it would considerably increase the possibility of the windows misting inside, especially if the climate control system is off.



It is advisable to turn on the inside air re-circulation system in queues or tunnels to avoid admitting polluted air from outside. The prolonged use of this function should however be avoided, especially with several persons on board, to avoid the possibility of the windows misting inside.



In certain weather conditions (e.g.: outside temperature around 0°C) and with automatic air re-circulation control on, mist may form on the windows. In this case press the inside air re-circulation button (8) , to switch off re-circulation (leds on button off) and if necessary increase the flow of air to the windscreen.

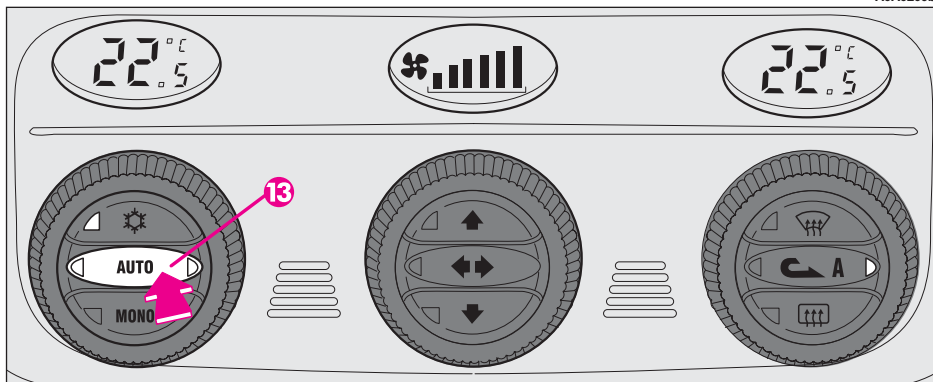

fig. 108

AUTOMATIC OPERATION AUTO BUTTON (fig. 108)

Pressing the (13) **AUTO** button the system automatically adjusts the amount and distribution of the air admitted to the passenger compartment, cancelling all the previous manual adjustments.





This condition is indicated by the lighting up of both leds on the button itself.

When the right led, on button (13) **AUTO** is off, this means that one or more manual operations have been carried out and therefore automatic control is not complete (except temperature control which is always automatic) indicated by the left led on, or that the system is in the **OFF** condition.

FRONT WINDOWS FAST DEMISTING/DEFROSTING (MAX-DEF) FUNCTION (fig. 109)

Pressing button (7)  the climate control automatically activates timed operation of all the functions needed to quicken demisting/defrosting of the windscreen and front side windows, i.e.:

- it turns on the climate control compressor;
- switches off inside air re-circulation, if on (both leds off);
- sets the maximum air temperature (HI) on both displays (1) and (5);
- operates the fan at a predefined speed;
- directs the flow of air towards the windscreen and front side window vents;
- turns on rearscreen heating and, if present, the wing mirror coils.

When the maximum demisting/defrosting feature is on, the led on button (7) , the led on the rearscreen heating button (9)  and the led on button (14)  turn on; at the same time the leds on button (8) .

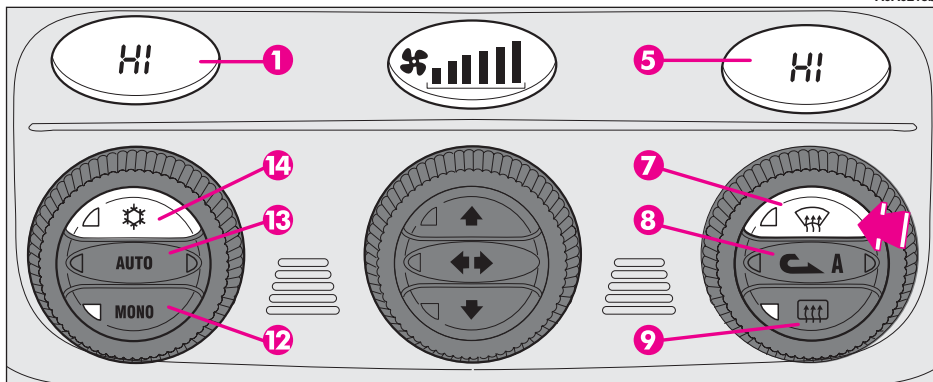





fig. 109

IMPORTANT If the engine is not hot enough, the function does not immediately engage the pre-established fan speed, to restrict the inlet of air to the passenger compartment that is not warm enough to demist the windows.

When the maximum demisting/defrosting function is on, the only manual operation possible are manual adjustment of the fan and switching rearscreen heating off.

Pressing one of the following buttons again: (7) , (8) , (12) **MONO**, (13) **AUTO** or (14)  the system switches off the maximum demisting/defrosting function, restoring the operating conditions of the system prior to turning it on, in addition to activating the last function required, if any.

WING MIRROR AND REARSCREEN DEFROSTING/DEMISTING BUTTON (fig. 110)

Pressing button (9)  turns on demisting/defrosting of the rearscreen and, if present, the wing mirror coils.

The turning on of this function is shown by the turning on of the led on the button.

This function is timed and switches off automatically after 20 minutes, or pressing the button again; the function is also switched off when the engine is stopped and will not be switched on again the next time the engine is started.

IMPORTANT The system automatically turns on rearscreen heating if the temperature is below 3°C.

IMPORTANT Do not apply stickers on the inside of the rearscreen over the heating filaments to avoid damage that might cause it to stop working properly.

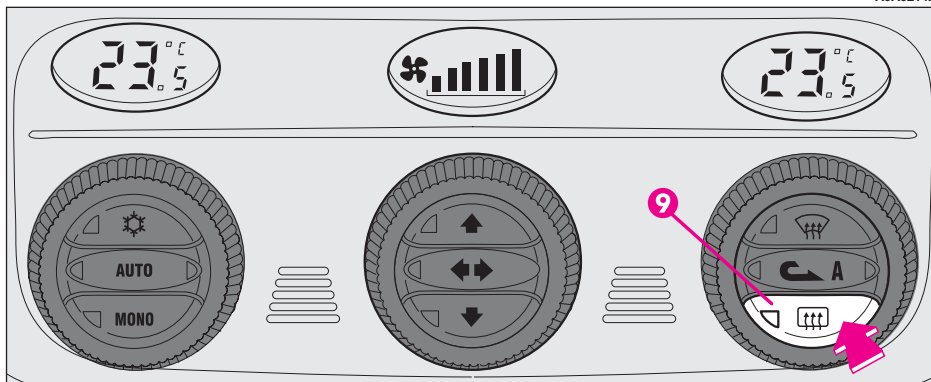

fig. 110

POLLEN FILTER

The filter has the specific capability of filtering external air, thus admitting to the passenger compartment purified air, free from particles such as dust, pollen, etc.

In addition to the above mentioned functions, it also reduces the concentration of pollutants.

The filtering action takes place under all air inlet conditions and it is clearly most effective with the windows shut.

Have the conditions of the filter checked by Alfa Romeo Authorised Services at least once a year, preferably at the onset of summer.

If the car is used mainly in dusty or polluted areas it should be checked and, if necessary, replaced at shorter intervals.



If the filter is not replaced the efficiency of the climate control system may be seriously compromised up to blocking the air flow at the outlets and vents.

PARKING SENSORS

(fig. 111)

(upon request for versions/markets where applicable)

Parking sensors are located in the rear bumper and their function is to inform the driver, through an intermittent buzzer, about the presence of obstacles behind the car.

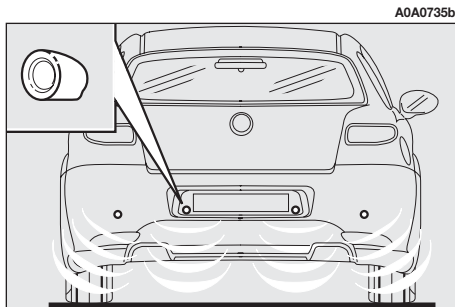

fig. 111

ACTIVATION

Sensors are automatically activated when the reverse gear is engaged.

As the distance from the obstacle behind the car decreases, the acoustic alarm becomes more frequent.

BUZZER WARNINGS

When the reverse gear is engaged an intermittent acoustic signal is automatically activated.

The acoustic signal:

- becomes louder as the reduction of distance between the car and the obstacle decreases;
- becomes continuous when the distance between the car and the obstacle is less than 30 cm and stops immediately if the distance raises.
- is constant if the distance is unvaried. If this situation takes place for side sensors, the signal is stopped after about 3 seconds to prevent sound indications when performing manoeuvres near walls.

OPERATION WITH TRAILER



Parking sensor operation is deactivated automatically when the trailer electric cable plug is fitted into the car tow hook socket.

Sensors are reactivated automatically when removing the trailer cable plug.

CONTROLS

TAILGATE OPENING (fig. 112)

Electric tailgate release is only allowed with the ignition key in the ignition switch at **MAR** car stationary, at **STOP** or **PARK** for 3 minutes without opening/closing a door. To release the tailgate, press button **(A)** on the central console panel.

HAZARD WARNING LIGHTS (fig. 112)

They are switched on by pressing button **(C)**, on the central console panel, regardless of the position of the ignition key.

When the hazard lights are switched on, the switch itself begins to flash together with the direction indicators and warning lights on the instrument panel. This function is switched off by pressing the button again.



Use of the hazard lights is ruled by the Highway Code of the country in which the car is used. Observe regulations.

FOG LIGHTS (fig. 112)

These are turned on pressing button **(B)**, on the centre console panel, when the outer lights are already on, at the same time the led on the button itself turns on.

Press button **(B)** again to switch off.

IMPORTANT The front foglights should be used in compliance with the local traffic laws.

REAR FOG GUARDS (fig. 112)

These are turned on, with the dipped beam headlights or fog lights on, pressing button **(D)** on the centre console panel, at the same time the warning light on the button itself turns on.

Turning the ignition key to **STOP** the fog guards are automatically turned off and they do not come on the next time the engine is started unless button **(D)** is pressed. To turn them off press button **(D)**.

IMPORTANT Always use the rear fog guards in compliance with local regulations.

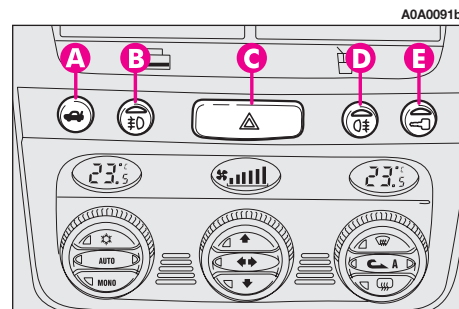

fig. 112

DOOR LOCKING SYSTEM (fig. 112)

To lock the doors simultaneously, press button **(E)**, on the centre console panel, regardless of the position of the ignition key.

The deterrent led turns on as follows:

- with the ignition key at **MAR** glowing steadily with a yellow light;
- with the ignition key at **STOP** flashing with a red light (deterrence condition).

INERTIAL FUEL CUT-OFF SWITCH (fig. 113)

This is an automatic safety switch, to be found on the floor next to the driver's door pillar, which is triggered in the event of a crash of a certain magnitude to interrupt the flow of fuel.

The cutting in of the inertial switch is shown on the display of the instrument cluster.



If a smell of fuel is noted following an accident, or the fuel system is leaking, to avoid the risk of fire do not reset the switch.

If no leaks are found the car can be restarted. Press button **(A)** to activate the fuel supply system again.

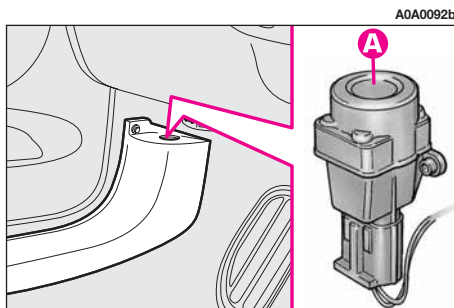

fig. 113

HEADLIGHT AIMING DEVICE (fig. 114)

The headlights should be aimed correctly depending on the car load.

For the required adjustment (only possible with low beams on), press buttons ▲/▼:

– press button ▲, to increase by one position (e.g.: 0 → 1 → 2 → 3);

– press button ▼ to decrease by one position (e.g.: 3 → 2 → 1 → 0);

The display (A), in the tachometer shows positions during adjustment.

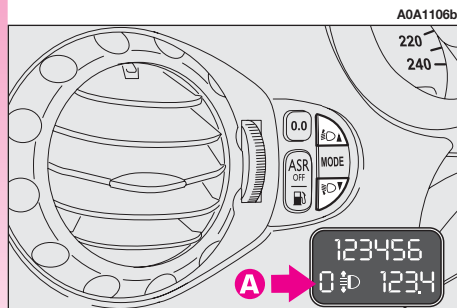

fig. 114

Correct positions as a function of the load:

- position **0**: one or two people occupying the front seats
- position **1**: five people;
- position **2**: five people + load in the boot;
- position **3**: driver + 350 Kg load all stowed in luggage compartment



Adjust the beams every time the load carried changes.

Xenon headlights aiming is automatic, versions with this optional are therefore not fitted with headlight aiming device.

HAND BRAKE (fig. 115)

The hand brake lever is located between the two front seats.

To operate the brake when the car is stationary, pull lever (A) upwards, until the required braking action is obtained.

When the ignition key is at **MAR**, the warning light on the instrument cluster (C) will come on.



The wheels should be locked after a few clicks of the hand brake. If it does not occur contact Alfa Romeo Authorised Services to have the hand brake adjusted.

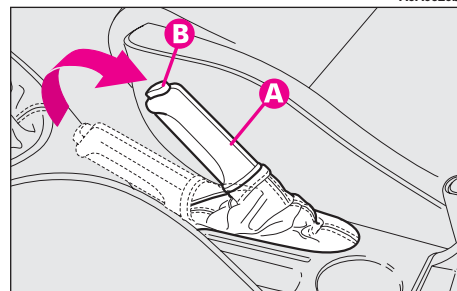

fig. 115

To release the hand brake:

- slightly lift the lever (**A**) and press the release button (**B**);

- keeping the button pressed lower the lever, the warning light (Ⓢ) on the instrument cluster will go out.

To prevent the car from moving accidentally, keep the brake pedal pressed when engaging the hand brake.

IMPORTANT The hand brake lever (**A**) is fitted with a safety device which prevents the brake from being released when, with the lever pulled, button (**B**) is pressed. Therefore, to release the brake, in addition to pressing button (**B**), it is also necessary to pull lever (**A**) further upwards to release the safety device, then lower the lever completely.

IMPORTANT On certain versions a buzzer sounds to alert the driver if the car is moved with the hand brake engaged.

GEARSHIFT LEVER (fig. 116)

The position of the single gears is shown by the pictogram on the gearshift lever knob.

When shifting gear, always fully depress the clutch pedal. Before engaging reverse gear (**R**) wait for the car to be stationary.

Certain versions are equipped with 6-speed gearbox. For the versions with 6 gears, to engage reverse (**R**) lift (with the fingers of the same hand holding the lever) the ring (**A**-fig. 116) positioned under the lever. After engaging the reverse, release the ring. To change from reverse to another gear, it is not necessary to lift the ring on the lever.

IMPORTANT Reverse gear may only be engaged with the car completely at a standstill. With the engine running, before engaging reverse gear it is necessary to wait for at least 3 seconds with the clutch pedal fully depressed to prevent clashing and the possibility of damaging the gears.



To change gear smoothly, the clutch pedal must be fully depressed. Therefore, there should be no obstacles on the floor under the pedal unit: make sure that any mats are well laid and do not interfere with the pedals.

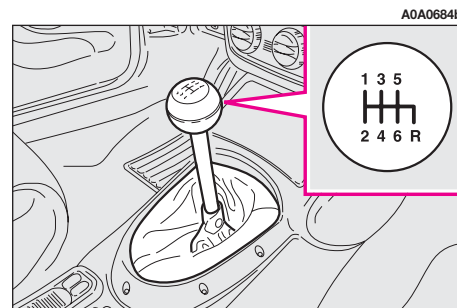

fig. 116

SELESPEED TRANSMISSION

(on request for versions/markets where applicable)

IMPORTANT To be able to use the Selespeed correctly, this chapter should be read in full to understand the correct, permissible operations to be carried out right from the start.

This device comprises a conventional mechanical transmission, to which an electronically-controlled electrohydraulic device has been added, which automatically controls the clutch and gear engagement.

The clutch pedal has been eliminated and the car moves off using only the accelerator pedal.

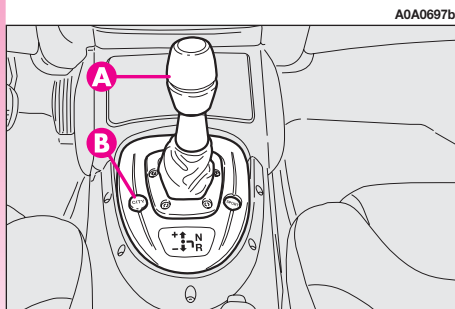

fig. 117

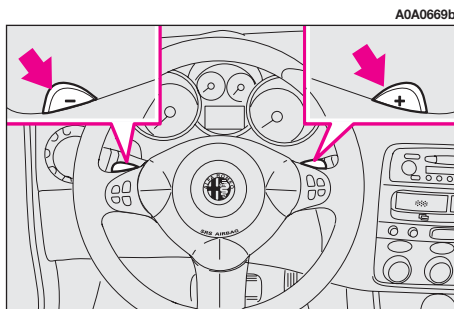

fig. 118

The gearbox can work according to two operating modes:

- the first is semi-automatic (hereinafter called **MANUAL**), in which the driver shifts gear directly using the lever on the central console or the levers on the steering wheel spokes;

- the second is automatic, called **CITY** (when selecting **CITY** with button **B-fig. 117**, the word **CITY** will be displayed **fig. 119**). In this mode the system decides directly when to shift gear.

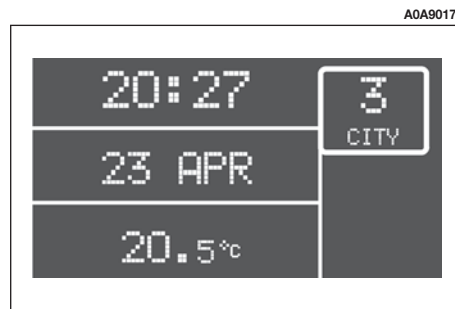

fig. 119

With gearshift to **CITY** gears can be shifted manually using both the gearshift lever or the steering wheel controls. Gearshift stays in **CITY**.

The gear selected (**fig. 119**) is always displayed regardless of the mode being selected selected .

N = neutral;

1 = first gear;

2 = second gear;

3 = third gear;

4 = fourth gear;

5 = fifth gear;

R = reverse.

In **CITY** or **SPORT**, the selected mode is also displayed.

IMPORTANT SPORT mode can only be activated after deactivating the **CITY** mode.

A warning light, a message (**fig. 120**) and a buzzer draw the attention of the driver in the event of a fault at Selespeed transmission.

The Selespeed considerably simplifies use of the car, reducing the fatigue of city driving or when frequent gearshifting is required, at the same time offering brilliant performance.

SYSTEM ACTIVATION

IMPORTANT Opening the driver's door, the Selespeed starts the hydraulic part of the system to prepare it for the engine to be started.

Turning the ignition key to **MAR**, all the segments of the display (**fig. 119**), the gearbox warning light (**fig. 120**) and the word **CITY** turn on. After about one second, the display indicates the gear engaged (**N, 1, 2, 3, 4, 5, R**).

IMPORTANT If after 10 seconds the display segment do not display the gear engaged or the warning light stays on, turn the ignition key to **STOP** and wait for the display to go off, then repeat the system activation procedure. If the fault persists, contact Alfa Romeo Authorized Services.

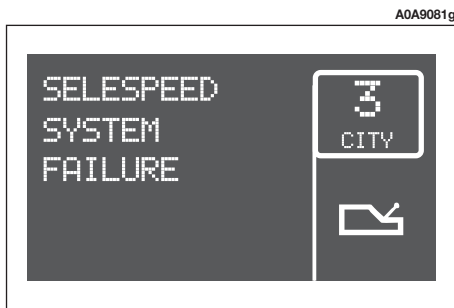

fig. 120

OPERATION WITH ENGINE OFF

IMPORTANT Before using the gearshift control lever, always check the gear engaged on the display (**N**, **1**, **2**, **3**, **4**, **5**, **R**).

With the engine off and the car stationary it is possible to engage all the gears.

With the car stationary and with the brake pedal pressed, requests to shift gears are both accepted through the control lever on the central console or through the steering wheel levers.

To request gearshifting, in addition to keeping the brake pedal pressed:

– to shift upwards (+) (**fig. 121**) push the lever “forwards” (if the car is in first gear it shifts to second, if in second it shifts to third and so on up to fifth). If the system is in neutral (**N**) or reverse (**R**) moving the

lever forwards causes the engagement of first gear (**1**).

– to shift downwards (–) (**fig. 121**) push the lever backwards (if the car is in fifth gear it shifts to fourth, if in fourth it shifts to third and so on down to first gear).

To allow setting the transmission to neutral (**N**), starting from the condition with the car stationary and brake pedal pressed, move the gearshift lever to the right (**fig. 122**).

From any gear (**N**, **1**, **2**, **3**, **4**, **5**) and with the car practically at a standstill, it is possible to request engagement of reverse gear, pushing the lever to the right and then backwards (**fig. 123**).

If the car is on the move, the request is not accepted; wait for the car to stop and then request reverse gear engagement again.

IMPORTANT Once a gear has been changed it is necessary to immediately release the gearshift control lever after making the request. A manoeuvre prolonged (over 10 seconds) makes the system automatically switch to **CITY** mode; everything stops releasing the gearshift lever.

IMPORTANT If wanting to leave the car parked on a sloping road with a gear engaged to keep it braked, it is necessary to check that the display shows the new gear engaged and then wait for 1 to 2 seconds before releasing the brake pedal to allow complete clutch engagement.

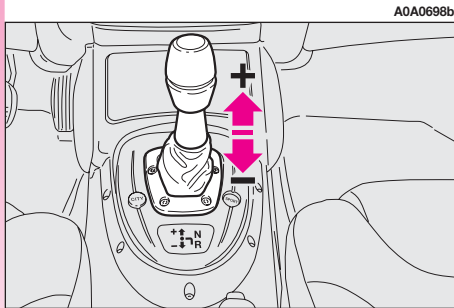

fig. 121

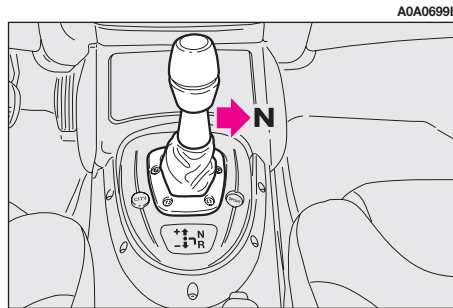

fig. 122

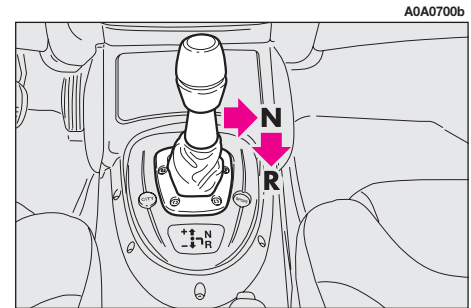

fig. 123

STARTING THE ENGINE

The engine can be started with the gear engaged or in neutral (**N**), provided that the brake pedal is pressed down.

IMPORTANT Keep the pedal fully depressed during starting. Since the brake pedal becomes hard if it is pressed repeatedly with the engine off, in this situation it is necessary to increase the pressure on the pedal itself to start the engine.

After starting, the gearbox sets to neutral automatically, the display shows the letter (**N**) and the system selects the operating mode memorised before switching off.



If the engine fails to start with the gear engaged, the driver is alerted of the potentially dangerous situation due to the fact that the gearbox has automatically set to neutral by the buzzer and the display.

SWITCHING OFF THE ENGINE AND SYSTEM DEACTIVATION

Turning the ignition key to **STOP** the engine switches off: the gear selected before turning the engine off remains engaged.

If the engine stops with the gearbox in neutral (**N**), the buzzer and the blinking of (**N**) draw the attention of the driver so that the car can be put in safety conditions engaging the first gear (**1**) or reverse (**R**). In this case, it is necessary to turn the ignition key to **MAR** and with the brake pedal pressed, engage first gear (**1**) or reverse (**R**).



NEVER leave the car with the gears in neutral (**N**).



Never remove the ignition key when the car is moving. In addition to the fact that the Selespeed system would not work properly up to stopping the car, the steering wheel would lock automatically the first time it is turned.



It is absolutely necessary to turn off the engine consequently deactivating the Selespeed system keeping the brake pedal pressed: release the pedal ONLY when the display goes off.

MOVING OFF THE CAR

With the engine running and the car stationary, the gears that can be engaged for moving off are only first **(1)**, second **(2)** or reverse **(R)**.

To engage them it is possible to use the control lever on the centre console, with the brake pedal pressed, as the steering wheel levers allow gear engagement only over 0.5 km/h.

IMPORTANT Reverse gear **(R)** can be engaged from each of the following other ratios: neutral **(N)**, first gear **(1)** or second gear **(2)**. If the car is on the move, the request is not accepted; it is necessary to wait for the car to be completely stopped and then request reverse **(R)** again.

The driver is informed of the reverse gear engaged condition by the intermittent sound of the buzzer as well as by the display.

IMPORTANT If while shifting from reverse **(R)**/first gear **(1)** or neutral **(N)**/first gear **(1)** sticking occurs on the first gear, the system automatically engages second gear **(2)**.

This should not be considered a failure because it is part of the operating logic. For the same reason, if sticking occurs on reverse gear, the system controls partial clutch closing so that the gear can be engaged; in this case the engagement of reverse gear **(R)** will not be as smooth as usual.

Moving off the car is obtained:

- 1) releasing the brake pedal;
- 2) gradually pressing the accelerator pedal.

The more the accelerator pedal is pressed the higher the car pick-up torque will be.



After a request to shift gear with the car stationary, before pressing the accelerator pedal to make the car start, the driver must always check that the gear engaged shown on the display is the one required.

IMPORTANT NOTES

- With the car stopped and a gear engaged always keep the brake pedal pressed until deciding to move off;

- during prolonged halts with the engine running it is advisable to keep the gearbox in neutral;

- when the car is parked facing uphill, do not use the moving off manoeuvre to keep the car still; use the brake pedal and press the accelerator pedal only when deciding to move off;

- use second gear only when more control is needed for moving off manoeuvres at low speed;

- if, with reverse gear engaged, you need to engage first gear or vice versa, shift gear only when the car is completely stationary and with the brake pedal pressed.

Though strongly inadvisable, if due to unforeseen circumstances when driving downhill the car is allowed to travel with the gearbox in neutral (**N**), when the engagement of a gear is requested, the system automatically engages the best gear to allow transmission of the torque to the wheels in relation to the speed of the car.

When travelling downhill with a gear engaged and the accelerator released (if the car is moving), beyond a pre-established speed, the system engages the clutch automatically to give the car adequate engine braking.

For safety reasons the Selespeed system activates the buzzer when: clutch overheating occurs during car starting; in this case, it is necessary to “force” moving off avoiding hesitations or to release the accelerator and use the brake pedal to park the car if the car is on a slope.

Still due to safety reasons, with the car stationary, the engine running and gear (**1**), (**2**) or (**R**) engaged, the system activates the buzzer and automatically shifts to neutral (**N**) when:

- no action is made on the accelerator and/or brake pedals for at least 3 minutes;

- the brake is pressed for over 10 minutes;

- the driver’s door is opened and the accelerator and brake pedal are not pressed for at least 1.5 seconds.

STOPPING THE CAR

To stop the car, simply release the accelerator pedal and, if necessary, press the brake pedal.

Regardless of the gear engaged and the operating mode activated (**MANUAL** or **CITY**) the system automatically disengages the clutch and shifts to a lower gear.

If deciding to move off again without having stopped the car completely, the most suitable ratio will be available for accelerator again.

Stopping the car the system automatically engages first gear (**1**).

OPERATION

The gearbox can work according to two operating modes:

— the first one is semi-automatic (**MANUAL**): the decision to change gear is left to the driver who decides the most appropriate moment; this mode features the two following logics:

1) normal: for comfort driving;

2) sport: (to be activated by button **B-fig. 124**): for sporty driving.

Sport operating mode is selected by pressing button **SPORT (B-fig. 124)** set on the gearshift lever; when selecting this mode, the display will show **SPORT**.

— the second one is fully automatic (**CITY**), in which the system decides directly when to shift gear according to driving conditions.

To select the **CITY** mode, press button **CITY** set on the gearshift lever; when selecting this mode, the display will show **CITY**.

SEMI-AUTOMATIC OPERATION (MANUAL)

In the **MANUAL** operating mode the display shows the gear engaged.

In this operating mode, the decision to change gear is left to the driver who decides the most appropriate moment.

The requests to change gear may take place through:

- the control lever on the centre console (**A-fig. 124**);
- the buttons on the steering wheel (**fig. 125**), which can be operated only when the car speed exceeds 0.5 km/h.

The **MANUAL** operating mode is set when, with the **CITY** mode selected, the **CITY** button (**A-fig. 126**) is pressed again, thereby cutting out the previously selected mode.

When changing gear it is not necessary to release the accelerator pedal because the Selespeed system directly controls the engine in such a way as to:

- reduce and then increase engine torque;
- adapt the engine speed to the new gear ratio engaged.

When downshifting, the engine is accelerated automatically to bring it to the speed necessary with the new gear ratio.

Neutral (**N**) is accepted until the car speed exceeds 40 km/h.

The reverse gear engagement command (**R**) is accepted only if the car is stationary.

A0A0702b

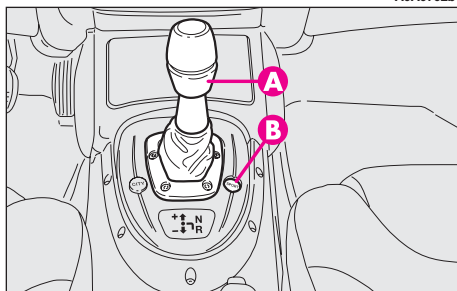

fig. 124

A0A0669b

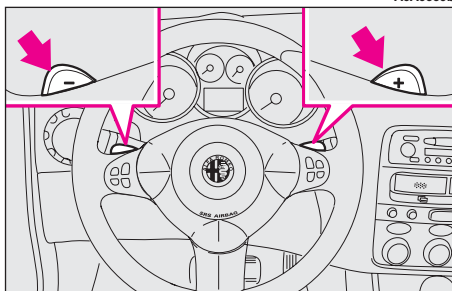

fig. 125

With the accelerator pedal pressed to over 60% of its stroke and an engine speed above 5000 rpm, gearshifting becomes quicker. In the **MANUAL** operating mode there are certain automatic/security devices which simplify driving:

- when slowing down, the clutch is disengaged and the gear ratio is reduced automatically to be ready for possibly picking up speed again; if not, stopping the car, first gear (1) will be engaged automatically;

- request to change gear that could take the engine above the maximum rpm or below the minimum permissible rpm are not accepted;

- if sticking occurs during the engagement of a gear, the system firstly tries to engage the required gear again and, if it is still not possible, it automatically engages the immediately higher one to avoid leaving the car in neutral .

IMPORTANT It is advisable to wait for the end of a gear shifting operation before requesting another one, to avoid multiple requests in rapid succession.

AUTOMATIC OPERATION (CITY)

The **CITY** automatic operating mode is selected pressing the button (**A-fig. 126**) at the base of the gearshift lever.

In addition to the gear, the display will show the word **CITY**.

The system decides directly when to shift gears in relation to the engine rpm and driving conditions.

Releasing the accelerator pedal quickly, the system does not engage a higher gear in order to maintain an adequate level of engine brake.

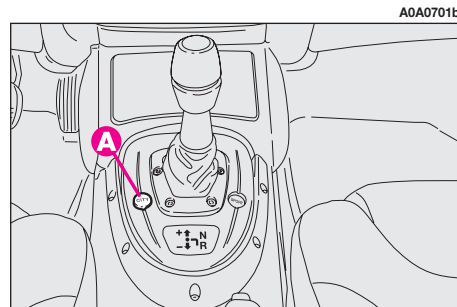



fig. 126

FAILURE INDICATIONS

Failures to the Selespeed gearbox are indicated on the display by warning light  (fig. 127), dedicated message and buzzer.



If the warning light  and the message are displayed, contact Alfa Romeo Authorized Services as soon as possible to have the fault eliminated.

In the event of a fault to the gearshift lever, the system automatically activates the automatic **CITY** mode to allow the car to reach the nearest Alfa Romeo Authorized Services to have the fault detected eliminated.

In the event of a fault to the other gearbox components, the system only allows the engagement of certain gears: first gear (**1**), second gear (**2**) and reverse (**R**).



In the event of whatever transmission fault, contact Alfa Romeo Authorized Services as soon as possible to have the system checked.

A0A9081g



fig. 127

BUZZER WARNINGS

The buzzer is activated when:

- reverse gear is engaged (**R**);
- the car is parked with the gearbox in neutral (**N**); signal that can be noted turning the ignition key to **STOP**;
- clutch overheating occurs when moving off;
- the system has shifted automatically to neutral (**N**) when:
 - there is no action on the accelerator and/or brake pedal for at least 3 minutes;
 - or the brake is pressed for over 10 minutes;
 - or the driver's door is opened and no action is made on the accelerator and brake for at least 1.5 seconds;
 - or detection of a gearbox fault;
- gearbox fault.

PARKING THE CAR

To park the car safely it is absolutely necessary to engage first gear (**1**) or reverse (**R**) and also the handbrake if the road is on a slope.

Turning the engine off with the car facing uphill and a gear engaged, it is absolutely necessary to wait for the gear display to go off before releasing the brake pedal, so that the clutch is fully disengaged.

If the gearbox is in neutral (**N**) and wanting to engage a parking gear, the system should be activated and with the foot on the brake pedal it is necessary to engage (**1**) or (**R**).

TOWING THE CAR

IMPORTANT For towing the car, adhere to local regulations. Make sure that the gearbox is in neutral (**N**) (checking that the car moves when pushed) and proceed as for towing a normal car with mechanical gearbox following the instructions given in section "In an emergency".

If setting to neutral is not possible, do not tow the car and contact Alfa Romeo Authorized Services.



While towing the car do not start the engine.

INTERIOR FITTINGS

GLOVEBOX

On the dashboard there is a glovebox with lid and light.

To open use handle (A-fig. 128).

When the glovebox is opened with the key at MAR an inside courtesy light turns on (A-fig. 129).

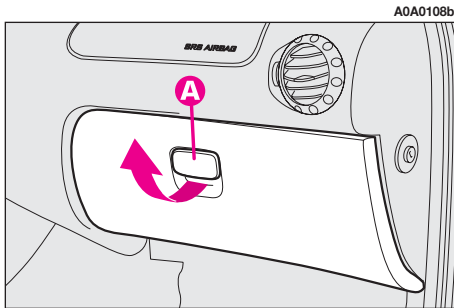

fig. 128



Never travel with the glovebox open: the lid might harm the passenger in the event of an accident.

The fitting is completed by device (B), on the lid, for inserting a pen or pencil.

IMPORTANT Turning the ignition key to **STOP**, opening the glovebox, the light inside can only be turned on for 15 minutes; after which the system turns it off to avoid draining the battery.

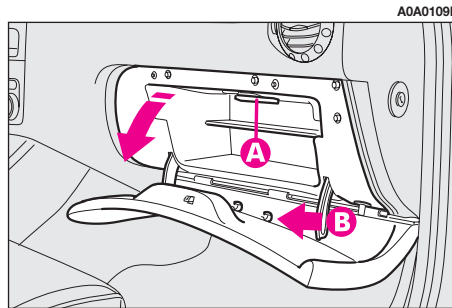

fig. 129

FRONT ROOF LIGHT (fig. 130)

The roof light comprises two courtesy lights with corresponding control switch.

IMPORTANT When a door is opened, the roof light turns on and timing of about 3 minutes is activated automatically, after which it goes off; closing the doors (within the 3 minutes) a second timing of about 7 seconds is activated to allow car starting.

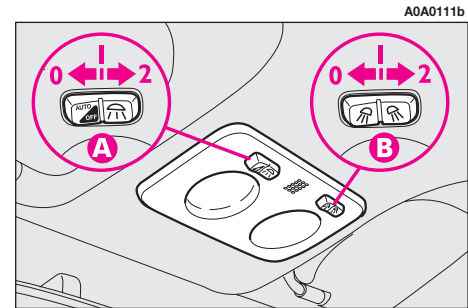

fig. 130

Unlocking the doors using the remote control, the roof light turns on gradually and timing is activated automatically for about 15 seconds. Locking the doors with the remote control the roof light turns off gradually.

The lights are turned off moving the ignition key to **MAR** (with the doors closed).

With switch **(A)** in the central position **(1)**, both lights are turned on when a door is opened.

Pressing switch **(A)** to the left (position **0**), the lights stay off (**OFF** position).

Pressing switch **(A)** to the right (position **2**) both lights stay on.

Switch **(B)** turns the lights on individually.

Pressing switch **(B)** to the left (position **0**) the left light is turned on. Pressing the switch to the right (position **2**) the right light is turned on.

With switch **(B)** in the central position (position **1**) the lights stay off.

IMPORTANT Turning the ignition key to **STOP**, turning the roof light on is only possible for 15 minutes; after which the system turns it off to avoid draining the battery.

IMPORTANT Before leaving the car, make sure that both switches are in the central position. By so doing, the roof lights will turn off when the doors are closed. Forgetting a door open the lights will turn off automatically after a few seconds.

COURTESY LIGHTS (fig. 131)

On the back of the driver's or passenger's sun visor, opening the cover **(A)** the roof lights turn on **(B)** at the side of the courtesy mirror, with the ignition key at **MAR**. These lights allow use of the courtesy mirror when the light is poor.

IMPORTANT Turning the ignition key to **STOP** the lights can be activated only for 15 minutes: after which the system turns them off to avoid draining the battery.

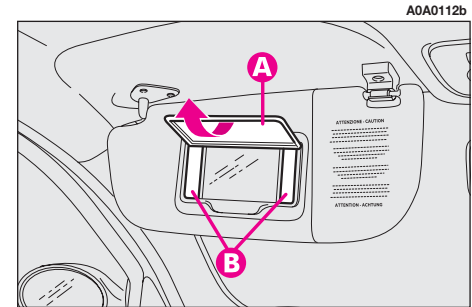

fig. 131

REAR ROOF LIGHT (fig. 132)

IMPORTANT When a door is opened, the roof light turns on and timing of about 3 minutes is activated automatically, after which it goes off; closing the doors (within the 3 minutes) a second timing of about 7 seconds is activated to allow car starting.

Unlocking the doors using the remote control, the roof light turns on gradually and timing is activated automatically for about 15 seconds. Locking the doors with the remote control the roof light turns off gradually.

The light turns off in any case turning the ignition key to **MAR** (with the door closed).

On the light there is a switch with three positions.

When switch **(A)** is in the central position **(O)** the light turns on automatically when a door is opened.

Moving the switch to the right (position **1**) the light stays off.

Moving the switch to the left (position **2**) the light stays on.

IMPORTANT Turning the ignition key to **STOP** the roof light can be turned on for only 15 minutes; after which it is turned off to avoid draining the battery.

IMPORTANT Before leaving the car, make sure that the switch **(A)** is in the central position **(O)**, so that the roof light turns off when the doors are closed.

PUDDLE LIGHTS (fig. 133) (for versions/markets where applicable)

The light **(A)** housed in the doors turns on when the associated door is opened, regardless of the position of the ignition key.

A0A0633b

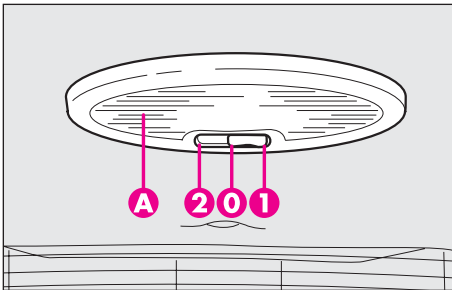

fig. 132

A0A0243b

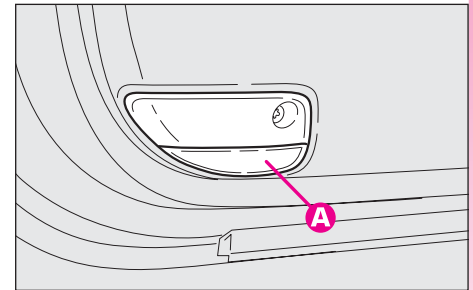

fig. 133

DETERRENT LED (fig. 134)

The led (**A**) on the instrument cluster comes into operation when the doors are locked (ignition key at **STOP** or removed) and it remains in the “deterrence” condition, flashing with a red light until the next time the doors are unlocked.

IMPORTANT If a door or the tailgate are not closed perfectly, the deterrent led flashes at a higher frequency for 4 seconds and then flashes at normal frequency again.

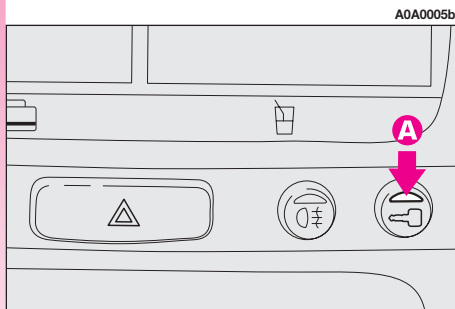

fig. 134

FRONT ASHTRAY AND CIGAR LIGHTER (fig. 135)

To gain access to the ashtray and the cigar lighter open the lid (**A**).

To use the cigar lighter, with the key at **MAR**, press button (**B**); after a few seconds the button will return automatically to its initial position and the cigar lighter is ready for use.

Remove the tray to empty and clean the ashtray (**C**).

The position of the cigar lighter in relation to the ashtray and viceversa, may vary depending on the trim level.

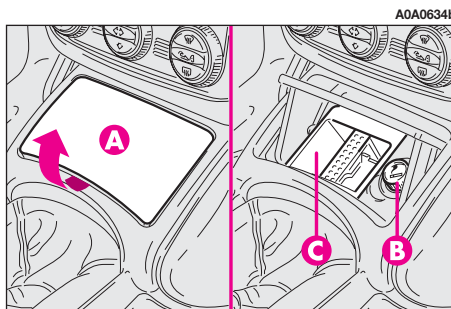

fig. 135



Do not use the ashtray as waste paper basket: it might set on fire in contact with cigarette stubs.



Always ensure that the cigar lighter has turned off.



The cigar lighter gets extremely hot. Handle with care and prevent its use by children: danger of fire and/or burning.

REAR ASHTRAYS (fig. 136)

For the rear passengers there are two concealed ashtrays.

To use or remove pull in the direction of the arrow.

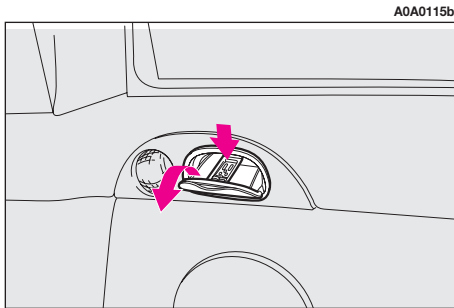

fig. 136

CARD HOLDER RECESS AND GLASS HOLDER (fig. 137) (for versions/markets where applicable)

The interior fittings are completed by the removable card holder recess (A) and glass holder (B) located on the centre of the dashboard. To use them, press as shown.

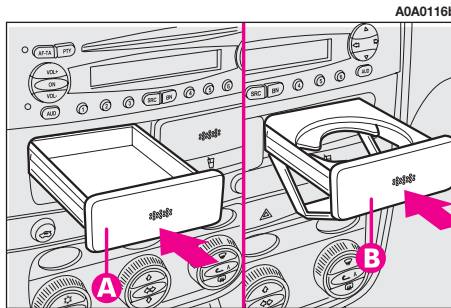

fig. 137

ODDMENT POCKETS ON FRONT DOORS (fig. 138)

Each front door has an oddment pocket (A).

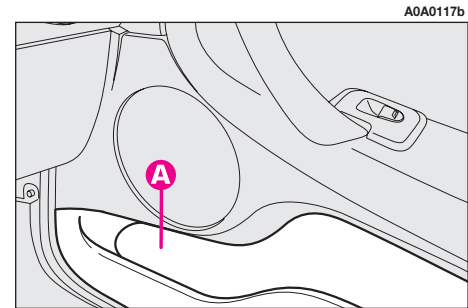
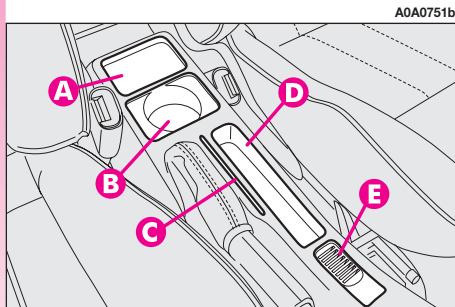

fig. 138

ODDMENT RECESSES ON CENTRE CONSOLE (fig. 139)

On the centre console, at the side of the hand brake lever, depending on the versions, the following recesses are provided:

- can holder (B);
- magnetic card or toll ticket holder (C);
- pen or pencil holder (D);
- coin holder (E).



A0A0751b

fig. 139

SUN VISORS (fig. 140)

The visors can be directed at the front and side.

Behind, the visors have a courtesy mirror with a light at the side (A). To use, open the cover (B).

The lights allow use of the mirrors with dim light.

The passenger's sun visor has a symbol concerning correct use of a child's seat in the presence of the passenger's air bag. For further details, refer to the passenger's front air bag paragraph.

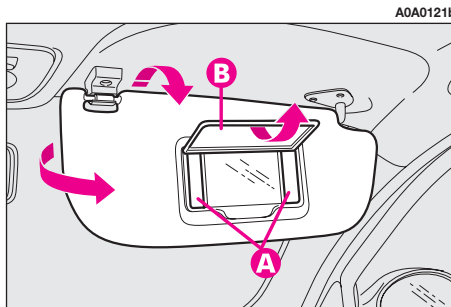

A0A0121b

fig. 140

CELL PHONE PROVISION

The car may be fitted with a provision for installing a cell phone.

The mobile phone provision consists of:

- radio + cell phone dual-purpose antenna;
- connection and supply cables with specific connector for connecting hands-free kit.



The voice kit should be purchased by the customer as it must be compatible with the customer's phone.



For the installation of a cell phone and connection to the provision in the car, contact only Alfa Romeo Authorised Services; this will guarantee first-rate results with no possibility of any inconvenience that may compromise the safety of the car.

INSTALLATION OF ELECTRIC/ELECTRONIC DEVICES

Electric/electronic devices installed after buying the car or in aftermarket shall bear the and marking:



Fiat Auto S.p.A. authorizes the installation of transceivers provided that installation is carried out at a specialized shop, workmanlike performed and in compliance with manufacturer's specifications.

IMPORTANT Installation of devices resulting in modifications of car characteristics may cause driving license seizing by traffic agents and also the lapse of the warranty as concerns defects due to the abovementioned modification or traceable back to it directly or indirectly.

Fiat Auto S.p.A. declines all responsibility for damages caused by the installation of non-genuine accessories or not recommended by Fiat Auto S.p.A. and installed not in compliance with the specified requirements.

RADIO TRANSMITTERS AND CELLULAR TELEPHONES

Mobile phones and other radio transceiver equipment (e.g.: HAM radio systems and the like) shall not be used inside the car unless a separate aerial is mounted.

IMPORTANT The use of mobile phones, HAM radio systems or other similar devices inside the passenger compartment (without separate aerial) may cause electronic systems equipping the car to malfunction. This could compromise safety in addition to constituting a potential hazard for the passengers.

In addition, transmission and reception of these devices may be affected by the shielding effect of the car body.

As concerns the use of mobile phones (GSM, GPRS, UMTS) with **CE** homologation, keep strictly to the mobile phone manufacturer's specifications.

ACCESSORIES PURCHASED BY THE OWNER

If after buying the car, you decide to install electrical accessories that require a permanent electric supply (alarm, voice feature, radionavigator with satellite antitheft, etc.) or accessories that in any case burden the electric supply, contact Alfa Romeo Authorised Services, whose qualified personnel, besides suggesting the most suitable devices belonging to Lineaccessori Alfa Romeo, will also evaluate the overall electric absorption, checking whether the car electric system is able to withstand the load required, or whether it needs to be integrated with a more powerful battery.

BOOT

The tailgate can be opened:

from the outside of the car - by a remote control impulse;

from the inside of the door - by depressing the button **(A-fig. 141)**.

IMPORTANT If the boot is not properly shut, the  warning light will come on (on certain versions accompanied by the message on the reconfigurable multifunction display).

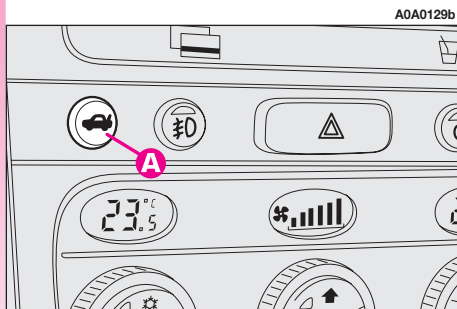

A0A0129b

fig. 141

OPENING FROM INSIDE (fig. 141)

Tailgate is released electrically and this can be performed only when the ignition key is in position **MAR** with car at a standstill or in **STOP** or **PARK** position for 3 minutes without unlocking/locking one of the doors.

To unlock the tailgate, press button **(A)** on the centre console panel.

Tailgate raising is facilitated by the gas shock springs.



The gas springs are calibrated to ensure correct tailgate raising with the weights foreseen by the manufacturer. The arbitrary addition of items (such as spoilers, etc.) may compromise the correct operation and safety of the actual tailgate.

OPENING WITH REMOTE CONTROL (fig. 142)

The tailgate can be opened by remote control from outside pressing the button **(A)**, also when the electronic alarm is engaged. Opening of the tailgate is accompanied by a double flash of the direction indicators; closing is accompanied by a single flash.

If an electronic alarm is fitted, with the opening of the tailgate, the alarm system switches off volumetric protection and the tailgate control sensor, the system “beeps” twice (with the exception of certain markets).

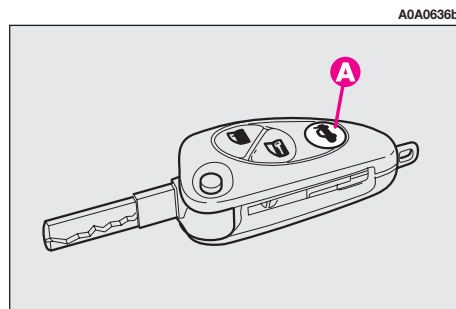

A0A0636b

fig. 142

Closing the tailgate again, the control functions are restored, the system “beeps” twice (with the exception of certain markets).

TAILGATE CLOSING

To lock, push in correspondence with the Alfa Romeo badge to lower tailgate, until you feel the click of the lock.

BOOT LIGHT (fig. 143)

When the tailgate is opened the light turns on automatically (**A**) in the right-hand side of the boot. Closing the tailgate, the light turns off automatically.

IMPORTANT Turning the ignition key to **STOP**, opening the tailgate, turning on the light will only be possible for 15 minutes; after which the system turns it off to avoid draining the battery.

EMERGENCY OPENING OF TAILGATE

To succeed in opening the tailgate from the inside, should the car battery be flat, or because of a defect of the electric lock of the tailgate itself, proceed as follows (see “Extending the luggage compartment” in the chapter “Getting to know your car”):

- tilt the rear seat cushions;
- tilt the backrests;
- unlock the lock by pulling the string (**A-fig. 144**) (the string is located inside the right recess in the tailgate).

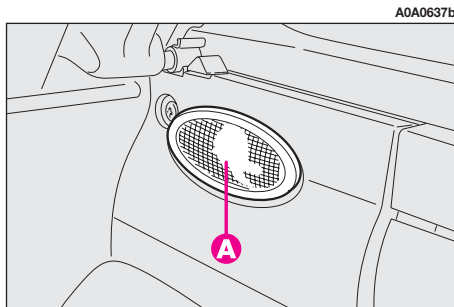

fig. 143

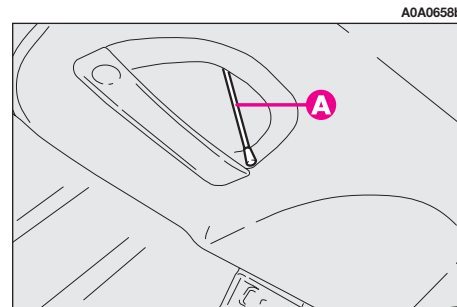
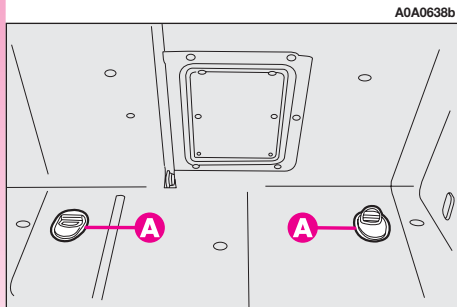

fig. 144

SECURING THE LOAD (fig. 145)

The loads carried may be secured with straps hooked to the special rings **(A)** in the boot.

The rings also serve for fastening the luggage restrainer, if present (in any case available c/o Alfa Romeo Authorised Services).



A0A0638b

fig. 145

CAUTIONS FOR CARRYING LUGGAGE

Travelling at night with a load in the boot it is necessary to adjust the height of the low beam headlights (see next paragraph "Headlights" in this chapter). For correct use of the aiming device, also make sure that the load does not exceed the values given in the same paragraph.



Do not load the boot above the permitted maximum (see "Technical specifications"). Also make sure that the objects contained in the boot are well secured to prevent them from being thrown forward, causing harm to the passengers.



A heavy load that has not been secured may cause serious harm to passengers.



If you want to carry reserve fuel in a can, follow legal regulations, only using a certified can, suitably fastened to the load securing eyelets. Even in this way the risk of fire is increased in the case of an accident.

BONNET

The bonnet opening lever is under the left end of the dashboard.

To open:

- pull the lever (**A-fig. 146**) until the bonnet clicks open.
- press the safety lever (**A-fig. 147**) upwards.
- raise the bonnet.

IMPORTANT Bonnet raising is aided by two gas springs. Do not tamper with these springs and accompany the bonnet while raising it.

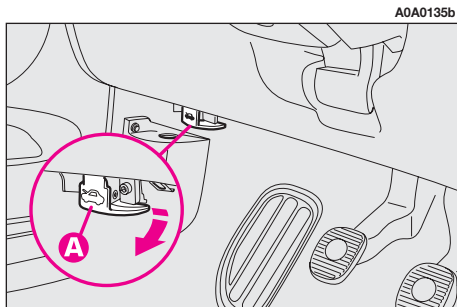

fig. 146



Carry out this operation only with the car stationary.



DANGER-SERIOUS INJURY. When carrying out checks or maintenance operations in the engine compartment, take special care not to bump the head on the raised bonnet.



If checks need to be carried out in the engine compartment when the engine is still warm, keep away from the fan as it could start up even when the key is removed from the ignition. Wait until the engine cools down.

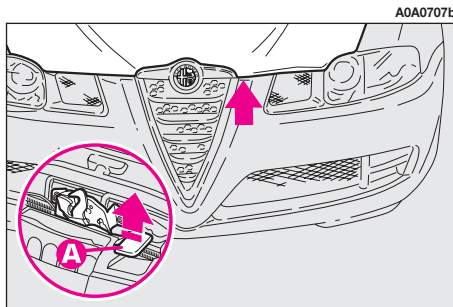

fig. 147



Scarves, ties and loose clothing may be caught in the moving parts.



For safety reasons the bonnet must be closed properly to avoid its opening while the car is travelling. Therefore, always check it is properly closed and the catch engaged. Should you notice that the catch is not perfectly engaged when travelling, stop the car immediately and close the bonnet.

To close:

- lower the bonnet until approx. 20 cm from the engine compartment and then let it drop, ensuring it is fully closed and not just held in position by the safety catch.

If the bonnet does not close properly do not push it down but open it again and repeat the above procedure.

HEADLIGHTS

The adjustment of the headlights is vital to your safety and comfort and to that of other road users.

The adjustment of the headlights is also governed by precise regulations.

Contact Alfa Romeo Authorised Services to have the headlights correctly adjusted.

IMPORTANT The headlight inner surface may get slightly misted: this does not mean it is faulty; it is a natural phenomenon due to low temperature and the air humidity level. Misting will disappear as soon as the headlights are turned on. The presence of water drops inside the headlight indicates water infiltration: contact Alfa Romeo Authorised Services.

COMPENSATION FOR TILT (fig. 148)

When the car is loaded, the beam from the headlights is raised due to the backwards tilt of the car.

In this case the headlights must be adjusted correctly.

For the required adjustment (only with low beams on), use buttons ▲/▼:

— press button ▲, to increase by one position (e.g.: **0** → **1** → **2** → **3**);

— press button ▼, to decrease by one position (e.g.: **3** → **2** → **1** → **0**);

The display (**A**), in the tachometer shows positions during adjustment.

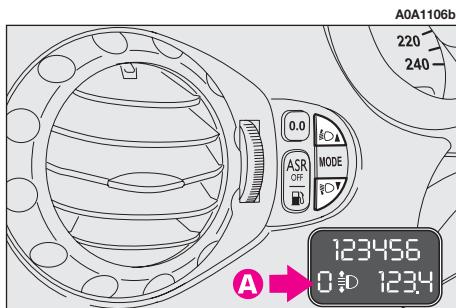

fig. 148

Correct positions as a function of the load:

- position **0**: one or two people occupying the front seats
- position **1**: five people;
- position **2**: five people + load in the boot;
- position **3**: driver + 350 Kg load all stowed in luggage compartment

IMPORTANT Xenon headlights aiming is automatic, versions with this optional are therefore not fitted with headlight aiming device.



Check beam aiming every time the load carried changes.

HEADLIGHT ADJUSTMENT ABROAD (fig. 149-150)

The dipped-beam headlights are adjusted for circulation in the country in which the car is marketed. In countries with opposite circulation, to avoid glaring oncoming vehicles it is necessary to cover the area of the headlights as shown below; this is done using non-transparent sticker tape.

The illustrations refer to passing from right-hand drive to left-hand drive.

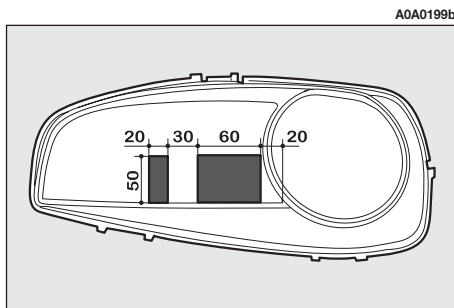

fig. 149

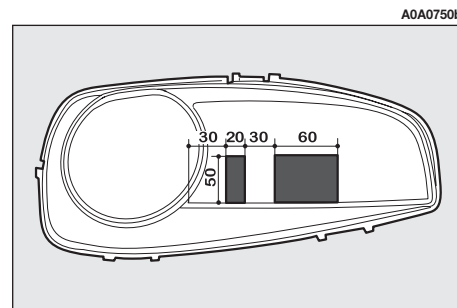

fig. 150

ABS (on request for versions/markets where applicable)

The car is fitted with an ABS braking system, which prevents the wheels from locking when braking, makes full use of the grip and within the limits of the grip available, keeps the car controllable also in emergency braking.

When braking a slight pulsing accompanied by noise may be felt on the brake pedal due to the action of the ABS system.

This should not be interpreted as a braking malfunction. It is the signal to the driver that the ABS has come into action: it is the warning that the car is travelling at the limit of its grip and therefore the speed should be adapted to the type of road.

The ABS system is an additional part of the base braking system; in the event of a failure it is disabled, leaving the braking system in the same conditions as a car without ABS.

In the case of a failure, the anti-lock action is no longer present, the braking capacity of the car is not adversely affected at all.

If you have never previously used cars fitted with ABS, it is advisable to practice a little on a slippery surface, naturally in safety conditions and in accordance with the local Highway Code; you are also advised to read the following instructions carefully.

The advantage of the ABS over a conventional system is that it makes it possible to obtain the highest degree of handling also when braking completely under limited grip conditions, preventing the wheels from locking.

However, with the ABS do not expect the braking distance to always shorten: for example, on soft surfaces like gravel or fresh snow or a slippery surface, the space might increase.

To better exploit the possibilities of the anti-lock system in the case of need, the advice given below should be followed.



The ABS better exploits the grip available, but cannot increase it; caution is therefore necessary on slippery surfaces, without taking unnecessary risks.



If the ABS cuts in it means that the limit of the grip is being reached between the tyre and the road surface: it is therefore necessary to slow down to adapt driving to the grip available.



In the event of a system failure, with the turning on of the  warning light on the instrument cluster, have the car checked immediately by Alfa Romeo Authorised Services, to be able to have the system restored to fully efficient conditions.

Always take due care when braking on bends, even with the help of the ABS.

The most important advice of all, however, is this:



When the ABS cuts in, and you feel the pulsing on the pedal, do not lighten the pressure, but keep the pedal firmly pressed with no fear; this way you will stop in the least space possible, compatibly with the conditions of the road surface.

Following these instructions you will be in the best braking condition under all circumstances.



IMPORTANT Cars fitted with ABS may only be fitted with the wheel rims, tyres and brake linings of type and brand approved by the Manufacturer.



The system is completed by the EBD (Electronic Brake Distributor) which distributes the braking action through the control unit and the ABS system sensors.



If the compact spare wheel is used, operation of the ABS system is cut off and the  warning light on the instrument cluster turns on.



The car is fitted with an electronic braking distributor (EBD). If the  and  warning lights turn on simultaneously with the engine running, this indicates an EBD system failure; in this case with sharp braking the rear wheels might lock too early, with the possibility of skidding. Driving extremely carefully, go to the nearest Alfa Romeo Authorised Service to have the system checked.

IMPORTANT If the battery is run down the  and  warning lights might turn on when starting the engine and go off after starting. This should not be considered as a fault but as a warning that during starting the ABS is not active. The turning off of the warning lights ensures normal system operation.



The turning on of only the  warning light with the engine running normally indicates a fault to the ABS system only. In this case the braking system is still efficient, though without the aid of the anti-lock device. Under these conditions performance of the EBD system may be reduced. In this case too, you are advised to go immediately to the nearest Alfa Romeo Authorised Service to have the system checked over, driving in such a way as to avoid sharp braking.



If the low brake fluid level  warning light turns on, stop the car immediately and contact the nearest Alfa Romeo Authorised Service. Any loss of fluid from the hydraulic system will negatively affect the operation of the braking system be it of the conventional type or of the type with ABS.

VDC SYSTEM (Vehicle Dynamics Control) (on request for versions/ markets where applicable)

The VDC is an electronic system that controls car stability, intervening on the driving torque and braking the wheels in a differentiated manner, in the lack of grip, it helps to bring the car back to the correct direction.

When travelling the car is subjected to lateral and longitudinal forces which can be controlled by the driver as long as the tyres offer adequate roadholding; when this falls below the minimum level, the car begins to divert from the course required by the driver.

Especially when travelling on an uneven surface (such as paving, or due to the presence of water, ice or soil), changes in speed (acceleration or braking) and/or course (bends or the need to avoid obstacles) may cause the tyres to lose grip.

When the sensors detect the conditions that would lead to skidding, the system intervenes on the engine and on the brakes producing a stabilising torque.



The performance of the system, in terms of active safety should not induce the driver to take pointless and unnecessary risks. The style of driving must in any case always be adapted to the conditions of the road surface, visibility and traffic. The responsibility for road safety is always and in any case the driver's.

System helps the driver to keep the car under control in the event of a loss of tyre grip.

The forces induced by the system to control the loss of car stability always depend on the grip between the tyre and the road surface.

HOW THE VDC SYSTEM WORKS

System is engaged automatically when the car is started and cannot be switched off.

The basic components of the system are:

- an electronic control unit that processes the signals received from the various sensors and brings about the most appropriate strategy;
- a sensor that detects the position of the steering wheels;
- four sensors that detect the turning speed of each wheel;
- a sensor that detects rotation of the car around its vertical axis;
- a sensor that detects lateral acceleration (centrifugal force).

The heart of the system is the control unit, which with the data supplied by the sensors installed on the car calculates the centrifugal forces generated when the car is cornering. The yawing sensor, which originates from the aeronautical industry, detects the rotations of the car around its own vertical axis. The centrifugal forces generated when the car is cornering are detected by a highly sensitive lateral acceleration sensor.

The stabilising action of the system is based on the calculations of the system electronic control unit, which processes the signals received from the steering wheel rotation sensor, acceleration sensor and rotation speed sensor of each wheel. These signals allow the control unit to recognise the manoeuvre the driver intends to do when the steering wheel is turned.

The control unit processes the information received from the sensors and therefore is able to know the position of the car instant by instant and compares it with the course the driver would like to follow. In the event of a discrepancy, in a fraction of a second the control unit chooses and commands the most suitable intervention to bring the car immediately back to the required course: braking one or more wheels at different intensity and, if necessary, reducing the power transmitted by the engine.

The corrective actions are modified and controlled continuously in seeking the course required by the driver.

The action of system considerably enhances the active safety of the car in very critical situations and it is particularly helpful when the grip conditions of the road surface change.

CUTTING IN OF THE VDC SYSTEM

The cutting in of the system is indicated by the flashing of the warning light on the instrument cluster, to inform the driver that the car is in critical conditions of stability and grip.

VDC system failure warning

In the event of a failure the system disengages automatically and the  warning light on the instrument cluster turns on glowing steadily, together with the message on the reconfigurable multifunction display.

In the event of an system failure the car behaves like a car not fitted with this system: in any case it is advisable to contact Alfa Romeo Authorised Services as soon as possible.



During use of the compact spare wheel, the VDC system continues working. It should be borne in mind that the spare wheel is smaller than a normal tyre, therefore its grip is lower than that of the other tyres of the car.



For the VDC system to work correctly, the tyres must be of the same brand and type on all wheels, in perfect conditions and above all of the specified type, brand and size.

ASR SYSTEM (Antislip Regulation) (on request for versions/ markets where applicable)

The ASR function controls the car drive and cuts in automatically every time one or both driving wheels slip.

In slipping conditions, two different control systems are activated:

1) if slipping involves both driving wheels, being caused by excessive power transmitted, the ASR device cuts in reducing the power transmitted by the engine.

2) if slipping involves only one driving wheel, the ASR system cuts in automatically braking the wheel that is slipping, with an effect similar to that of a self-locking differential.

The action of the ASR is particularly helpful in the following circumstances:

- slipping of the inner wheel on a bend, due to the effect of dynamic load changes or excessive acceleration.
- too much power transmitted to the wheels also in relation to the conditions of the road safety.
- acceleration on slippery, snowy or frozen surfaces.
- in the case of loss of grip on a wet surface (aquaplaning).



The performance of the system in terms of active safety should not induce the driver to take pointless and unnecessary risks. The style of driving must in any case be adapted to the conditions of the road surface, visibility and traffic. Road surface is always the driver's responsibility.

SWITCHING ON THE ASR FUNCTION

The ASR function switches on automatically each time the engine is started.

When travelling the ASR can be switched off and on again pressing switch **(A-fig. 151)**.

When the function is turned off, the instrument panel warning light  turns on.

If the function is switched off when travelling, it will turn on again automatically the next time the engine is started.

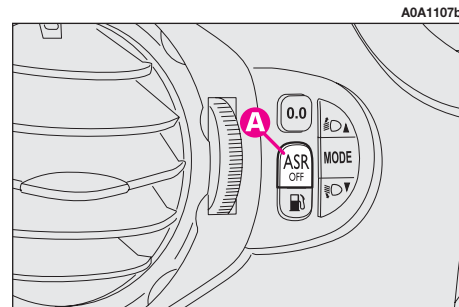



fig. 151



During use of the compact spare wheel, the ASR function is cut off and the  warning light on the instrument cluster turns on glowing steadily together with the message on the reconfigurable multifunction display.



For correct operation of the ASR system, the tyres must absolutely be of the same brand and type on all wheels, in perfect conditions and, above all, of type, brand and size specified.

IMPORTANT When travelling on snowy roads with snow chains, it may be helpful to turn the ASR off: in fact, in these conditions, slipping of the driving wheels when moving off makes it possible to obtain better drive.

ASR system failure indications

In the event of a fault, the ASR system switches off automatically and the  warning light on the instrument cluster turns on, together with the message on the reconfigurable multifunction display.

In the event of an ASR system operating failure, the car behaves in the same way as a car that is not fitted with this system: in any case, it is advisable to contact Alfa Romeo Authorised Services as soon as possible.

MSR SYSTEM (engine braking torque control)

The car is fitted with a special system, integral with the ASR system, that in case of sudden gear shifting, cuts in providing torque to the engine thus preventing excessive driving wheel drive that, specially in poor grip conditions, can lead to loss of stability.

EOBD SYSTEM

**(upon request for versions/
markets where applicable)**

The EOBD system (European On Board Diagnosis) allows continuous diagnosis of the components of the car correlated with emissions.

It also alerts the driver, by turning on the warning light  on the instrument panel (on certain versions together with message + symbol on the reconfigurable multifunction display), when these components are no longer in peak conditions.

The objective is:

- to keep the system efficiency under control;
- to warn when a fault causes emissions levels to increase;
- to warn of the need to replace deteriorated components.

The system also has a diagnostic connector that can be interfaced with appropriate tools, which makes it possible to read the error codes stored in the control unit, together with a series of specific parameters for engine operation and diagnosis. This check can also be carried out by the traffic police.



If, turning the ignition key to MAR, the warning light  does not turn on or if, while travelling it turns on glowing steadily or flashing (on some versions together with the message + symbol on the reconfigurable multifunction display), contact Alfa Romeo Authorised Services as soon as possible.

IMPORTANT After eliminating the inconvenience, to check the system completely, Alfa Romeo Authorised Services are obliged to run a bench test and, if necessary, road tests which may also call for a long journey.

SOUND SYSTEM

The car sound system, fitted with CD player (radio with Compact Disc player) or MP3 CD player (radio with MP3 CD player) has been designed in accordance with the special features of the passenger compartment, with a personalised design that blends with the style of the dashboard. The sound system cannot be adapted to other vehicles and for this reason it cannot be removed.

The radio is installed in a user-friendly position for the driver and passenger and the graphics on the front panel make location of the controls quick, facilitating use.

The CD Changer is available at Lineaccessori Alfa Romeo.

In the following pages you will find the instructions for use, which you are advised to read through carefully. The instructions also contain the procedure for controlling the CD Changer (if provided) through the radio. For the instructions for use of the CD Changer refer to the specific manual.

ADVICE

Road safety

You are advised to learn how to use the various radio functions (e.g.: storing stations) before starting to drive.

Reception conditions

Reception conditions change constantly when driving. Reception may be disturbed by the presence of mountains, buildings or bridges particularly when far away from the station being listened to.

IMPORTANT When receiving traffic information, the volume may be higher than normal.



Too high a volume when driving can put the driver's life at risk and that of other people. Therefore the volume should always be adjusted in such a way that it is always possible to hear the noises of the surrounding environment (e.g.: horns, ambulance, police sirens, etc.).

Care and maintenance

The radio structure ensures long operation with no need for particular maintenance. In the event of a fault, contact Alfa Romeo Authorized Services.

To clean the front panel only use a soft, antistatic cloth. Cleaning and polishing products might spoil the surface.

Compact Disc

Remember that dirt, marks or distortion on Compact Disc can cause skipping. To obtain optimum playing conditions we give the following advice:

— Only use Compact Discs which have the following brand:



— Carefully clean all Compact Discs of fingerprints and dust using a soft cloth. Support Compact Discs from the outer circumference and clean from the centre outwards;

— Never use chemical products for cleaning (e.g.: spray cans, antistatic or thinners) as they might damage the surface of Compact Discs;

— After use, put Compact Discs back in their container, to avoid marks or scratches that may cause skipping when playing;

— Do not expose Compact Discs to direct sunlight, high temperatures or damp for prolonged lengths of time to prevent them from bending;

— Do not stick labels or write on the recorded surface of Compact Discs.

To remove a Compact Disc from its container, press the centre and raise the disc carefully, holding it by the outer circumference.

Always hold Compact Discs by the outer circumference. Never touch the surface.

To remove fingerprints and dust, use a soft cloth starting from the centre of the Compact Disc outwards.

Do not use highly scratched, cracked, or distorted discs, etc. The use of these discs will involve malfunctioning or damage to the player.

For optimal playing use original CDs only. Regular operation is not guaranteed if using R/RW CDs not properly mastered and/or CDs with max. capacity higher than 650 MB.

IMPORTANT Do not use the protective sheets for CD in commerce or discs with stabilisers, etc. as they might get stuck in the internal mechanism and damage the disc.

IMPORTANT Should copy-protected CDs be used, then, few seconds may be required for playing them. Moreover, due to the proliferation of always new and different protection methods, it is not guaranteed that the CD player can play whatever protected disc. Copy protection is often indicated on the CD cover in small letters or hard to read characters. Usually it is indicated by writings like: "COPY CONTROL", "COPY PROTECTED", "THIS CD CANNOT BE PLAYED ON A PC/MAC", or it is identified by symbols like:



Protected discs (and their cover) very often are not marked with the audio CD identification symbol:



IMPORTANT The CD player can read most of the compression systems currently on sale (e.g.: LAME, BLADE, XING, FRAUNHOFER) however, due to the evolution of these systems, reading of all compression formats is not guaranteed.

IMPORTANT When loading a multi-session CD, only the first session will be played.

TECHNICAL DATA

Radio

Maximum power: 4 x 30W.

Aerial

The aerial is located on the car roof. You are recommended to slacken and remove the aerial from the roof to avoid damaging it when washing the car in automatic system.

Speakers

The sound system is formed of a system comprising:

- 4 tweeters: 2 front and 2 rear (for versions/markets where applicable) with 30W power
- 4 speakers with a diameter of 165 mm (2 front and 2 rear) with 40W power.

Protection fuse

The radio has a 10A fuse located in the rear part of the set. To replace the fuse, the radio needs to be pulled out: therefore contact Alfa Romeo Authorised Services.

HI-FI BOSE SYSTEM (for versions/markets where applicable)

The HI-FI BOSE system installed on your car has been accurately designed to offer outstanding sound quality and reproduce the musical realism of a live concert, for all the seats in the passenger compartment.

The system's features include outstanding faithful reproduction of crystalline treble tones and full, rich basses which among other things, make the Loudness function superfluous. In addition, the complete range of the sounds is reproduced in the whole passenger compartment enveloping the occupants with the natural spatial sensation that is felt when listening to live music.

The components adopted are patented and are the result of the most sophisticated technology, but at the same time they are easy and intuitive to use, so that even less expert people can use the system.

Technical information

System comprises:

- 4 high efficiency woofers with diameter 165 mm, two at the front and two at the back, each having a coaxial tweeter inside;
- 1 bass box with a volume of 12 dm³ housed on the left-hand side of the boot;
- 1 high power HI-FI amplifier (150W) with 6 channels, analogue equalising in amplitude signal phase and with 130 mm diameter sub-woofer.

CONTROLS ON FRONT PANEL

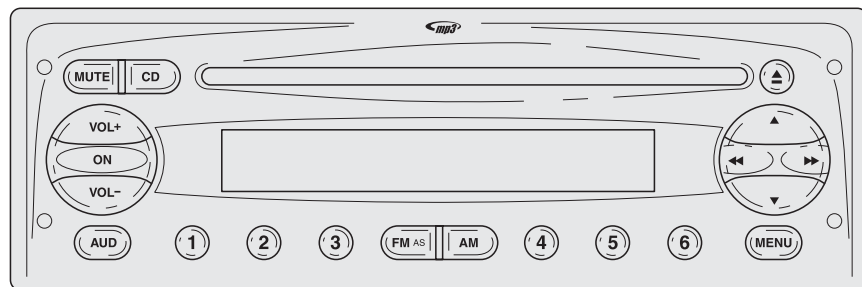

fig. 152

A0A1113b

Radio section

- Traffic information reception (TA)
- Automatic storage of 6 stations in the dedicated FM band - FMT (AS – Autostore)

Audio section

- Loudness function (excluding versions with Bose HI-FI system)
- Standard equalization (excluding versions with Bose HI-FI system)
- Personal equalization (excluding versions with Bose HI-FI system)
- Automatic volume changing according to car speed
- MUTE function

CD / CD MP3 section

- Play / Pause
- Previous / next track selection
- FF / FR
- Previous / next directory selection

Button	GENERAL FUNCTIONS	Mode
ON	On	Short push on button
	Off	Long push on button
VOL+	Volume up	Press button
VOL	Volume down	Press button

Button	GENERAL FUNCTIONS	Mode
FM AS	Radio band selection FM1, FM2, FM Autostore	Brief cyclic button pressing
AM	Radio band selection MW, LW	Brief cyclic button pressing
CD	Audio source selection (radio/CD/CD-Changer)	Brief cyclic button pressing
MUTE	Volume on/off (MUTE / PAUSE)	Brief button pressing
AUD	Audio settings: bass (BASS), treble (TREBLE), right/left sound adjustment (BALANCE), front/rear sound adjustment (FADER)	Menu activation: brief button pressing Adjustment selection: press button ▲ or ▼ Value adjustment: press button ◀◀ or ▶▶
MENU	Advanced functions adjustment	Menu activation: brief button pressing Adjustment selection: press button ▲ or ▼ Value adjustment: press button ◀◀ or ▶▶

Button	RADIO FUNCTIONS	Mode
▲ ◀◀ ▶▶ ▼	Radio station tuning: • Automatic tuning • Manual tuning	Automatic tuning: press button ◀◀ or ▶▶ (long pressing for fast forward) Manual tuning: press button ▲ or ▼ (long pressing for fast forward)
1 2 3 4 5 6	Current radio station storage	Long button pressing respectively for preset/memories from 1 to 6
	Stored station recall	Brief button pressing respectively for preset/memories from 1 to 6

Button	CD FUNCTIONS	Mode
▲	CD ejection	Brief button pressing
◀◀ ▶▶	Previous/next track playback	Brief pressing on buttons ◀◀ or ▶▶
	CD track fast forward/backward	Long pressing on buttons ◀◀ or ▶▶
▲	Previous/next CD playback (for CD Changer)	Brief pressing on buttons ▲ or ▼
▼	Previous/next directory playback (for MP3 CD)	Brief pressing on buttons ▲ or ▼

STEERING WHEEL CONTROLS (where provided)

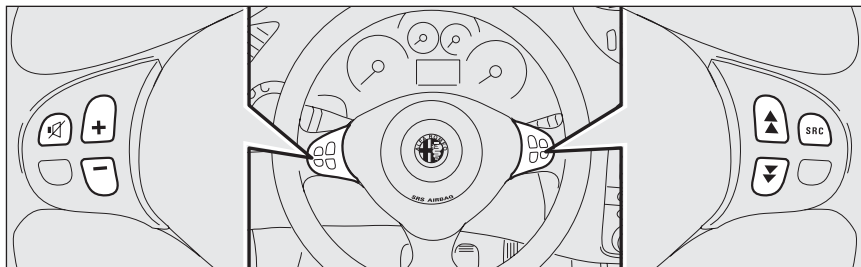

fig. 153

A0A1114b

Button	FUNCTION	Mode
	Audio Mute on/off (with sound system on)	Brief button pressing
+	Volume up	Press button
-	Volume down	Press button
SRC	Radio frequency (FM1, FM2, FMT, MW, LW) and audio source (Radio - CD - MP3 - CD Changer) selection button	Press button
	Radio: recall preset stations (1 to 6) MP3: select next directory CD Changer: select next CD in the CD Changer	Press button
	Radio: recall preset stations (6 to 1) MP3: select previous directory CD Changer: select previous CD in the CD Changer	Press button

GENERAL

The set possesses the following functions:

Radio section

- PLL tuning with FM/AM/MW/LW frequency bands;
- RDS (Radio Data System) with TA (traffic announcements) - TP (Program Type) - EON (Enhanced Other Network) - REG (Regional programmes);
- AF: alternative frequency search selection in RDS mode;
- emergency alarm presetting;
- automatic/manual station tuning;
- FM Multipath detector;
- manual storage of 36 stations: 18 in the FM band (6 in FM1, 6 in FM2, 6 in FMT), 6 in the MW band and 6 in the LW band;
- automatic storage (Autostore function) of 6 stations in FM band;
- SVC function (excluding versions with Bose HI-FI system): automatic volume adjustment with car speed;
- automatic Stereo/Mono switching.

Compact Disc section

- Direct disc selection;
- Track selection (forward/backward);
- Fast forward/backward;
- CD Display function: displaying CD name/time elapsed from start of track;
- Playing audio CDs and R/RW CDs.



On multimedia CDs in addition to sound tracks also data tracks are recorded. Playing one of these CDs may cause rustling and such a volume as to compromise road safety, as well as causing damage to the final stages and speakers.

CD MP3 section

- Directory selection (previous/next);
- Track selection (forward/backward);
- Fast forward/backward;
- MP3 DISP function: directory name, ID3-tag info, time elapsed from start of track, file name);
- Playing audio CDs and R/RW CDs.

Audio section

- Mute/Pause function;
- Soft Mute function;
- Loudness function (excluding versions with Bose HI-FI system);
- 7 band graphic equalizer (excluding versions with Bose HI-FI system);
- Separate bass/treble adjustment;
- Right/left channel balancing.

FUNCTIONS AND ADJUSTMENTS

Turning the sound system on The set is switched on pressing button ON.

When turning the sound system on, the volume level will be brought to 20 if it was set to over.

If the radio is turned on when the key is not fitted into the ignition device, it will turn off automatically after about 20 minutes. After automatic switching off, it is however possible to turn the radio on again for other 20 minutes by pressing button ON (see paragraph "IGN TIME function").

Turning the sound system off

Keep button ON pressed.

Selecting radio functions

Pressing briefly and repeatedly button FMAs it is possible to select the following functions in sequence:

– TUNER ("FM1", "FM2", "FMT");

Pressing briefly and repeatedly button AM it is possible to select the following functions in sequence:

– TUNER ("MW", "LW").

Selecting CD/CD Changer functions

Pressing briefly and repeatedly button CD it is possible to select the following audio sources in sequence:

– CD (only if the Compact Disc is inserted);

– CHANGER (only if the CD Changer is connected).

Audio source memory function

If while listening to a CD another function is selected (e.g.: the radio), playing is stopped and when the CD mode is resumed, it starts again from the point in which it was stopped.

If while listening to the radio another function is selected, when the Radio mode is resumed, it is tuned to the last station selected.

Volume adjustment

Adjust volume through VOL + and VOL - buttons.

If the volume level is changed during the broadcast of a traffic bulletin, the new setting is maintained only until the end of the bulletin.

SVC function (excluding versions with Bose HI-FI system)

The SVC function makes it possible to automatically adapt the volume level to the speed of the car, increasing it as the speed increases to maintain the ratio with the noise level inside the passenger compartment.

See section MENU for activating/deactivating this function.

Mute /pause function (turning off the volume completely)

To switch on the Mute function, briefly press the button MUTE. Volume will gradually lower and the display will show the word "MUTE" (when in radio mode) or "PAUSE" (when in CD or CD-Changer mode).

To switch off the Mute function, press the button MUTE again. Volume will gradually become louder returning to the value set before switching on the Mute function.

Changing volume will deactivate the Mute function and the volume will be set to the new level selected.

With the Mute function on:

– if an emergency alarm or a traffic bulletin arrives with the TA function on, the message ignores the Mute function. The Mute function will be resumed at the end of the traffic announcement.

Audio adjustments

The options proposed by the audio menu differ according to the audio source selected: AM/FM/CD/CDC.

To change Audio functions, press briefly button AUD. The display will show "BASS".

To scroll the Menu options, use buttons ▲ or ▼. To change the setting of the option selected, press buttons ◀◀ or ▶▶.

The display will show the current status of the function selected.

The functions controlled by the menu are the following:

- BASS (bass adjustment);
- TREBLE (treble adjustment);
- BALANCE (right/left balance);
- FADER (excluding versions with Bose HI-FI system) (front/rear balance);
- LD (excluding versions with Bose HI-FI system) (Loudness on/off);
- PRESET (excluding versions with Bose HI-FI system) (standard equalization activation and selection);
- XX USER (personal equalization setting).

Tone adjustment (bass/treble)

Proceed as follows:

- Use button ▲ or ▼ to select "BASS" or "TREBLE" in the AUDIO menu;
- press button ◀◀ or ▶▶ to increase/decrease the basses or trebles.

Pressing the buttons briefly the change is gradual by steps. Pressing longer, changing is faster.

Balance adjustment

Proceed as follows:

- Use button ▲ or ▼ to select "BALANCE" in the AUDIO menu;
- press button ◀◀ to increase the sound from the right speakers or button ▶▶ to increase the sound from the left speakers.

Pressing the buttons briefly the change is gradual by steps. Pressing longer, changing is faster.

Select "◀◀ 0 ▶▶" to set the same value for both right and left speakers.

Fader adjustment

Proceed as follows:

- Use button ▲ or ▼ to select “FADER” in the AUDIO menu;
- press button ◀◀ to increase the sound from the rear speakers or button ▶▶ to increase the sound from the front speakers.

Pressing the buttons briefly the change is gradual by steps. Pressing longer, changing is faster.

Select “◀◀0▶▶” to set the same value for both front and rear speakers.

LD function

The Loudness function improves the sound volume when listening at low level, increasing the basses and trebles.

To switch the function on/off, use button ▲ or ▼ to select “LD” in the AUDIO menu. The function condition (on or off) is shown on the display for few seconds by “LD ON” or “LD OFF”.

PRESET/XX EQ SET*/CLASSIC/ROCK/JAZZ functions (equalizer on/off)

The integrated equalizer can be turned on or off. With the equalizer off, it is possible to change the sound settings only adjusting the bass (“BASS”) and treble tones (“TREBLE”), while activating the function makes it possible to adjust the sound curves.

To turn the equalizer off, select “PRESET” by means of button ◀◀ or ▶▶.

To turn the equalizer on, use button ◀◀ or ▶▶ to select one of the following options:

- “USER” (adjustment of the 7 equalizer bands that can be changed by the user);
- “CLASSIC” (predefined equalizer adjustment for best playing of classic music);
- “ROCK” (predefined equalizer adjustment for best playing of rock and pop music);
- “JAZZ” (predefined equalizer adjustment for best playing of jazz music).

When one of the equalizer settings is on, the display shows “EQ”.

*XX EQ SET function (only if the USER equalizer setting has been selected) (excluding versions with Bose HI-FI system)

To set a personal equalizer adjustment, use button ▲ or ▼ to select USER and then press button ▼ for long.

The display will show for about 2 seconds “XX EQ SET” and then a graph with 7 bars, where each bar represents a frequency. Choose the bar to be adjusted using button ◀◀ or ▶▶; the bar chosen starts to flash and it is possible to adjust it using button ▲ or ▼.

To store the new settings, press button AUD again or wait for about 10 seconds. The display will show the word “MEN” together with the graph with 7 bars.

Antitheft protection

Refer to “CD Player” paragraph.

RADIO (TUNER)

Introduction

When the set is turned on the last function selected before turning off is played (Radio, CD or CD Changer).

To select the Tuner source while listening to another audio source, press briefly buttons FMAs or AM, according to the required frequency band.

When Tuner is on, the display will show the selected station name (RDS stations only) (or frequency), the frequency band (e.g.: FM1) and the preselection button number (e.g.: P1).

Selecting the frequency band

If in the Tuner mode, briefly and repeatedly press button FMAs or AM to select the required frequency band.

Every time the button is pressed the following bands are selected in sequence:

- Pressing button FMAs: “FM1”, “FM2”, “FMT”;
- Pressing button AM: “MW” and “LW”.

Each band is shown by the respective wording on the display.

The last station selected in the respective frequency band will be tuned.

The FM band is divided into sections: FM1, FM2 and FMT. The FMT reception band is reserved to the stations stored automatically with the Autostore function.

Presetting buttons

The buttons with symbols from 1 to 6 make it possible to set the following pre-settings:

- 18 in the FM band (6 in FM1, 6 in FM2, 6 in FMT);
- 6 in the MW band;
- 6 in the LW band;

To call a preset station, choose the required frequency band and then press briefly the corresponding preset button (from 1 to 6).

Pressing the respective preset button for longer than 2 seconds will store the tuned station. Storing is confirmed by a beep.

Storing the last station heard

The radio automatically keeps in storage the last station heard for each reception band, which is then tuned when the radio is turned on or the reception band is changed.

Automatic tuning

Briefly press button ◀◀ or ▶▶ to start automatically searching the tuning for the next station that it is possible to receive in the direction chosen.

If button ◀◀ or ▶▶ is pressed for longer, quick searching takes place. When the button is released, the tuner stops on the next receivable station.

If the TA function is on (traffic information), the tuner only searches stations which broadcast traffic bulletins.

Manual tuning

This allows manual station searching in the chosen band.

Select the required frequency band and then press briefly and repeatedly button ▲ or ▼ to start searching in the chosen band. Pressing one of the buttons ▲ or ▼ longer obtains fast forward searching, which is stopped when the button is released.

A-STORE function (automatic station storage)

To switch on the A-STORE function, keep button FMAS pressed until receiving the confirmation beep. With this function the radio automatically stores the six stations with the strongest signal in decreasing order of intensity of the FMT frequency band.

IMPORTANT Activating the A-STORE function cancels the stations stored previously in the FMT band.

If the TA function is on (traffic information), only the stations that send traffic information will be stored.

During automatic storage the display shows "A-STORE".

To interrupt A-STORE press button FMAS again: the radio will automatically tune to the station heard before activation of the AutoStore function.

At the end of the A-STORE function the radio automatically tunes on the first preset station in the FMT band stored on preset button 1.

On buttons numbered from 1 to 6, the stations are automatically stored that give a strong signal in that moment in the present band.

Activating the A-STORE function in MW or LW bands will automatically select the FMT band where the function is then run.

IMPORTANT Sometimes the A-STORE function is unable to find 6 stations with a strong signal. In this case the previous stations will be stored on the free preset buttons.

Emergency alarm reception

In the RDS mode the radio is set to receive emergency announcements in the case of exceptional circumstances or events that may cause general danger (earthquakes, floods, etc.), if they are broadcast by the station tuned.

This function is activated automatically and cannot be deactivated.

During emergency announcement the display will show the message "ALARM". During this announcement the volume will change as described for traffic announcements (see "TA Function").

EON function (Enhanced Other Network)

Certain countries have circuits which group together several stations enabled to broadcast traffic information. In this case the programme of the station being heard will be interrupted temporarily:

- to receive traffic information (only with TA function on);
- to listen to regional programmes every time these bulletins are given by one of the stations of the same circuits.

Stereophonic stations

If the signal received is weak, the device switches automatically from Stereo to Mono.

MENU

MENU button functions

To activate the menu function, briefly press button MENU. The display shows the word "MENU".

To scroll the menu functions use button ▲ or ▼. To change the setting of the selected function use button ◀◀ or ▶▶.

The display will show the current status of the function selected.

The functions controlled by the menu are the following:

- AF (alternative frequency search);
- TA (traffic information);
- REG (regional programmes);
- MP3 DISP (MP3 CD data display);
- SVC (automatic volume control in relation to speed);
- EXT VOL (external audio sources control);
- IGN TIME (System power off mode radio);
- DEFAULT (reset original settings).

To exit the menu function, press button MENU again.

AF function (alternative frequency search)

Within the RDS system the radio can work in two different modes:

- “AF ON”: alternative frequency search on (the display shows “AF”);
- “AF OFF”: alternative frequency search off.

With “AF ON”, the radio is automatically tuned to the station with the strongest signal that is broadcasting the same programme. During the journey it will thus be possible to continue listening to the station chosen without having to change the frequency when changing area.

Of course, the station being listened to must be receivable in the area the car is crossing.

To turn the AF function on/off, press button MENU, and then select “AF ON” or “AF OFF”. If the AF function has been turned on the display shows “AF”.

If the radio is working in the AM band, when the AF function is activated, it passes to the FM1 band on the last station selected.

TA function (traffic information)

Certain stations in the FM band (FM1, FM2 and FMT) are enabled to also broadcast information about traffic conditions. In this case the display shows “TP”.

To turn the TA (traffic announcement) function on/off, briefly press button MENU and then select “TA ON” or “TA OFF”.

IMPORTANT If the TA function (traffic information) is on, with CD, CD Changer (if installed), Telephone or Mute/Pause active: automatic station tuning will start.

With the TA function it is possible:

- to search only RDS stations that transmit in the FM band, enabled to broadcast traffic information;
- to receive traffic information although CD player or CD Changer are being used;
- to receive traffic information at a pre-defined minimum volume even with the radio volume off.

IMPORTANT In certain countries radio stations exist which, even if the TP function is on (the display shows “TP”), do not transmit traffic information.

If the radio is working in the AM band, when TA is activated, it passes to the FM1 band on the last station heard.

The volume with which the traffic bulletin is transmitted varies depending on the listening volume:

- listening volume below 20: traffic bulletin volume = 20 (fixed value);
- listening volume above 20: traffic bulletin volume = listening volume + 1.

If the volume is changed during a traffic bulletin the value is not shown on the display and the new value is kept only for the bulletin in progress.

The TA function is interrupted by pressing any sound system button.

REG function (regional broadcast reception)

Certain national broadcasters, at determinate times of the day, transmit regional programmes which differ from region to region. This function makes it possible to tune in only on local stations (regional) (see paragraph "EON function").

Activate this function if you want to tune automatically to regional stations broadcasting in the selected band.

To turn the function on/off use button ◀◀ or ▶▶.

The display will show the current status of the function:

- "REG ON": function on.
- "REG OFF": function off.

If the function is off and a regional programme is tuned that works in a determinate area and the car enters a different area, the regional station of the new area is received.

IMPORTANT If AF and REG are both active, when passing from one region to another the radio could not tune properly to a valid alternative frequency.

MP3 DISP function (MP3 CD data display)

With this function it is possible to choose the information shown on the display, when listening to a MP3 CD.

This function can be selected only if a MP3 CD is loaded: in this event the display shows "MP3 DISP".

To change the function use buttons ◀◀ or ▶▶.

The display shows the setting among the six possible:

- TITLE (track title, if ID3-tag available)
- AUTHOR (track author, if ID3-tag available)
- ALBUM (album title, if ID3-tag available)
- DIR (directory name);
- FILENAME (MP3 file name);
- TIME (time elapsed from start of track).

SVC function (volume changing with speed) (excluding versions with Bose HI-FI system)

This function makes it possible to automatically adapt the volume level to the speed of the car, increasing it as the speed increases to maintain the ratio with the noise level inside the passenger compartment.

To turn the function on/off use button ◀◀ or ▶▶. The display will show the current status of the function:

- SVC OFF: function off
- SVC LOW: function on
(low sensitivity)
- SVC HIGH: function on
(high sensitivity).

EXT function (external audio source control)

With this function it is possible to adjust (setting from 0 to 40) or exclude (OFF) external audio sources.

To turn this function on/off, use button ◀◀ or ▶▶.

The display will show the current status of the function:

- “EXT VOL”: function on.
- “EXT OFF”: function off.
- “EXT 23”: function on with volume level 23.

IGN TIME function (system power on/off mode radio)

This function enables to switch off the sound system according to two different modes. To turn the function on use button ◀◀ or ▶▶.

The display will show “IGN TIME” and then:

- “00 MIN”: deactivation dependent on ignition key. Sound system will switch off automatically when turning the ignition key to STOP;
- “20 MIN”: deactivation independent of ignition key. After having turned the ignition key to STOP the sound system will stay on for 20 minutes max.

IMPORTANT When the sound system is switched off automatically after turning the ignition key to STOP (for both immediate or 20-minute delayed power off), it will switch on automatically turning the ignition key to MAR. If the sound system has been switched off pressing button ON, when turning the key to MAR it will stay off.

RESTORE function

This function enables to restore default settings. Options available are the following:

- NO: no restore;
- YES: restore default settings. During this operation the display will show the message “RESTORE”. At the end of this operation, the audio source will not be changed and the previous situation is displayed.

COMPACT DISC PLAYER

Introduction

This section only describes CD player operation variants: as concerns sound system operation, refer “Functions and adjustments” paragraph.

Selecting the compact disc player

To turn on the Compact Disc player integrated in the set, proceed as follows:

— insert a CD with the set on: the first track will be played;

or

— if a CD is already inserted, turn the set on and press briefly button CD to select “CD”: the last heard track will be played.

For optimal playing use only original CDs. When using R/RW CDs, use top quality CDs mastered at the as low as possible speed.

Inserting/ejecting a CD

To insert the CD set it gently in place to activate the powered loading system, which will position it correctly.

Press button ▲, with the device on, to operate the powered CD eject system. After ejection, the source heard before playing the CD will return.

If CD is not ejected, the device will reload it automatically after about 20 seconds and then will set to Tuner (Radio).

CD cannot be ejected if the device is off.

Inserting the ejected CD without fully removing it from the slot, the tuner will not change the source to CD.

Possible error messages

If the CD inserted is illegible (e.g.: CD-ROM inserted, CD not inserted properly or reading error), the display will show the message "CD ERROR" for about 2 seconds.

The CD is then ejected and the previous source before CD was selected returns.

Display information

When the CD player is working, the display shows the following information which means:

"T05": shows the number of the track on the CD;

"03:42": shows the time elapsed since the start of the track (if the corresponding Menu function is on);

Select track (forward/backward)

Briefly press button ◀◀ to play the previous track and button ▶▶ to play the next one. Tracks are played in sequence: after the last track, the first one will be played and vice versa.

If playing the track started more than 3 seconds ago, pressing briefly button ◀◀ the track is played again from the start. In this case if wanting to play the previous track, press the button twice consecutively.

Fast forward/backward

Keep button ▶▶ pressed to move the track selected forward at high speed and keep button ◀◀ pressed to move it quickly backward. Fast forward/backward is stopped once the button is released.

Pause function

To pause the CD player, press button MUTE. The display will show "PAUSE".

To resume playing the track, press button MUTE again.

The pause function is deactivated changing the sound source.

Antitheft protection

The radio is fitted with an antitheft protection system based on the exchange of information between the radio and the electronic control unit (Body Computer) installed on the car.

This system warrants the highest level of security and prevents entry of the secret code every time the radio supply is disconnected.

If the result of the check is positive, the set starts working, whereas if the comparison codes are not the same or if the electronic control unit (Body Computer) is replaced, the device informs the user of the need to enter the secret code according to the procedure described in the following paragraph.

Entering the secret code

When turning the sound system on (in the event of code request), the display will show the word "CDC CODE" for about 2 seconds, followed by four dashes "----".

The secret code comprises four figures from 1 to 6, each corresponding to one of the dashes.

To enter the first digit of the code, press the corresponding key of the preset stations (from 1 to 6). Enter the other code digits in the same way.

If the four figures are not entered within 20 seconds, the display shows the word "CDC CODE" for 2 seconds and then four dashes "----". This is not to be considered as an incorrect code entry.

After entering the fourth digit (within 20 seconds), the radio starts working.

If a wrong code is entered, the radio sounds a beep, the display shows the word "CDC CODE" for 2 seconds and then four dashes "----" to warn the user that it is necessary to enter the correct code.

Every time the user enters a wrong code, the waiting time increases gradually (1 min, 2 min, 4 min, 8 min, 16 min, 30 min, 1h, 2h, 4h, 8h, 16h, 24h) until reaching a maximum of 24 hours. The waiting time will be shown on the display with the word "CDC WAIT". When this goes off it is possible to start the new code entry procedure.

Code Card

This the document that certifies possession of the radio. The Code Card contains the radio model, serial number and secret code.

IMPORTANT Keep the Code Card carefully to be able to give the related data to the competent authorities in the event of theft.

MP3 CD PLAYER (where provided)

Introduction

This section only describes MP3 CD player operation variants: as concerns sound system operation, refer to “Functions and Adjustments” paragraph.

NOTE MPEG Layer-3 audio decoding technology licensed from Fraunhofer IIS and Thomson multimedia.

MP3 mode

In addition to standard audio CDs, the sound system can also play audio files in MP3 format. Sound system will operate as described in “Compact Disc player” paragraph when inserting a conventional audio CD.

For optimal playing use only top quality CDs mastered at a speed as low as possible.

MP3 CD files are structured by directories, with sequential lists of all directories containing MP3 tracks (directories and sub-directories are all brought to the same level), directories not containing MP3 tracks cannot be selected.

Technical data and operating conditions for MP3 files are as follows:

- adopted CD-ROM shall be mastered according to ISO9660 Standard;
- music files shall be renamed as “.mp3” otherwise they cannot be played;
- sampling frequencies are: 44.1 kHz, stereo (96 to 320 kbit/s) - 22.05 kHz, mono or stereo (32 to 80 kbit/s);
- it is possible to play variable bit-rate tracks (files).

IMPORTANT Characters: blank, ‘ (apostrophe), (and) (open and closed brackets) are not admitted in MP3 track names. When sampling MP3 CD you must not use these characters to name files otherwise the sound system will not be able to play it.

DISPLAY INFORMATION

ID3-tag info display (track informations)

In addition to time elapsed, directory name and file name, also ID3-tag info relevant to track Title, Artist, Author (see section “MP3 disp function”) are displayed.

The MP3 directory name shown on the display corresponds to the name with which the directory is stored on the CD, followed by an asterisk.

Example of full MP3 directory name: BEST OF *.

If you want to display one ID3-tag info (Title, Artist, Album) and the track being played has no ID3-tag info then, the file name will be displayed.

Select next/previous directory

Press button ▲ to select the next directory or press button ▼ to select the previous one. The name of the new selected directory will be shown on the display.

Directories are selected in cyclic sequence: after the last directory the first one is selected and vice versa.

If no other directory/track is selected in the following 2 seconds, the first track in the new directory will be played.

If the last track in the currently selected directory is played, the next will then be played.

Protection against theft

Refer to “Compact Disc player” paragraph.

CD CHANGER (CDC)



Installation and connection of a Lineaccessori CD Changer shall only be performed by Alfa Romeo Authorized Services.

Introduction

This section only describes CD Changer (where provided) operation variants: as concerns sound system operation, refer to “Functions and adjustments” paragraph.

Selecting the cd changer

Turn on the set, then press briefly and repeatedly button CD until selecting “CHANGER”.

Possible error messages

Error messages will be displayed in the following cases:

— no CD in the CD Changer: the display will show “CD ERROR” until changing the sound source;

— selected CD is illegible (CD not in the selected position or CD not inserted properly): the display shows “CD ERROR” after the number of the selected CD. The next CD will be selected; if there are no other CDs or if they are also illegible the display will show the wording “NO CD” until the sound source is changed;

— error in CD reading: the display shows “CD ERROR”. The next CD will be selected; if there are no other CDs in the CD Changer (after the last CD search will restart from the first one) or they are also illegible, if the sound source is not changed, the display will show the following:

- “CHANGER” for about 2.5 seconds;
 - “CD ERROR” for about 5 seconds;
 - plays next source for other 5 seconds;
- a CD-ROM is inserted: next CD will be selected.

Selecting the CD

Press button ▲ to select the next CD and button ▼ to select the previous CD.

If the loader does not contain a disc in the position selected, the display briefly shows the wording “CD ERROR”, and the next CD is played automatically.

TROUBLESHOOTING

Overview

Low volume

The Fader function shall only be set to “F” (front), to prevent sound system output power reduction and volume muting if the Fader level set is = R+9.

Required source cannot be selected

No CD loaded. Load the CD or the MP3 CD you want to play.

Compact disc player

CD not played

Loaded CD is dirty. Clean the CD.
Loaded CD is scratched. Try to play another CD.

Required CD cannot be loaded

Another CD is already loaded. Press button ▲ and remove the CD.

MP3 file reading

Skipping when reading MP3 files

Loaded CD is scratched or dirty. Clean the CD as described in “CD” voice in “Advise” paragraph.

MP3 track length not displayed correctly

In certain cases (due to recording) MP3 track length can be displayed incorrectly.

REFUELLING

PETROL ENGINES

Use only unleaded petrol.

To prevent accidentally filling with leaded petrol, the diameter of the fuel tank filler is of such a size as not to accept the nozzle of this type of petrol.

The unleaded petrol octane number (R.O.N.) used shall not be less than 95.

IMPORTANT An inefficient catalyst leads to harmful emission at the exhaust, thus environment pollution.

IMPORTANT Under no circumstances should conventional leaded petrol be used, as this would irreparably damage the catalyst.

DIESEL ENGINES

If the outside temperature is very low, the diesel thickens due to the formation of paraffins and could clog the diesel fuel filter.

In order to avoid these problems, different types of diesel are distributed according to the season: summer type, winter type arctic type (mountains/cold areas).

If refuelling with diesel fuel not suitable for the current temperature, mix diesel fuel with **TUTELA DIESEL ART** additive in the proportions stated on the can, putting first the antifreeze in the tank and then the diesel fuel.

TUTELA DIESEL ART shall be added to diesel fuel before the due to cold take place. Adding it later will be worthless. If driving or parking the vehicle for a long period in cold areas/mountains, refuel with the diesel fuel available at local filling stations. In this situation you are also recommended to have in the tank an amount of fuel 50% higher than usable capacity.



Cars with diesel engines must only be filled with diesel fuel for motor vehicles, in compliance with European Specification EN590. The use of other products or mixtures may irreparably damage the engine with invalidation of the warranty due to the damage caused. In the event of accidentally filling with another type of fuel, do not start the engine and empty the tank. If the engine has been run even for only a very short time, in addition to the tank, it is also necessary to drain out the whole fuel circuit.

REFUELLING

To guarantee full tank filling, carry out two refuelling operations after the first click of the fuel delivery gun. Avoid further topping up operations that could cause damages to the fuel system.

FUEL CAP

The fuel cap (**C-fig. 154**) is electrically controlled. To open it, press button (**D-fig. 155**); the flap can be opened only when the engine is off.

The fuel cap (**A-fig. 154**), accessible after opening the lid (**C**), is fitted with a catch (**B**) which fastens it to the lid.

When refuelling, hook the cap to the device on the inner flap, as illustrated.

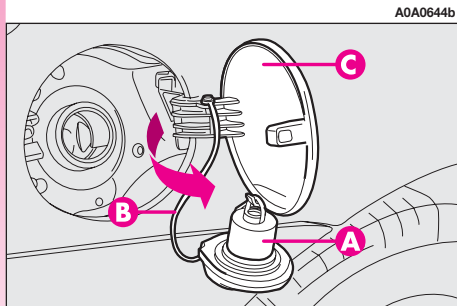

A0A0644b

fig. 154

IMPORTANT The sealing of the tank may cause light pressurising in the tank. A little breathing off, while slackening the cap, is absolutely normal.

After refuelling, turn the cap clockwise and close the flap.

IMPORTANT For your safety, make sure that the fuelling pump nozzle is inserted correctly into the housing, before starting the engine.



Do not put naked flames or lighted cigarettes near the fuel filler hole as there is a danger of fire. Do not bend too close to the hole either so as not to breathe in harmful vapours.

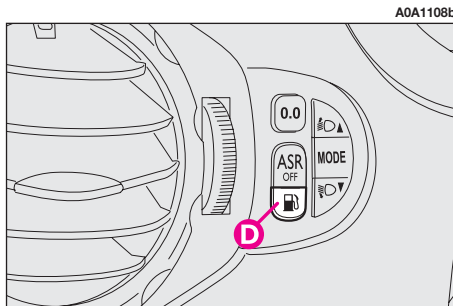

A0A1108b

fig. 155



If required, replace the fuel cap only with a genuine new one to prevent impairing the petrol vapour system.

Should it be not possible to open the fuel flap electrically, use the special cable in the boot (**A-fig. 156**) to open it manually.

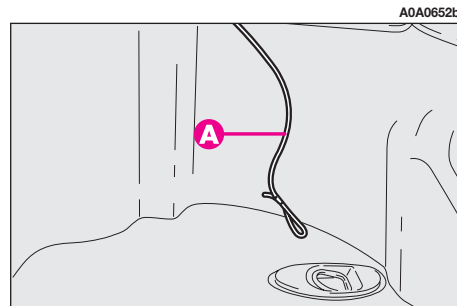

A0A0652b

fig. 156

ENVIRONMENTAL PROTECTION

The devices used to reduce petrol engine emissions are:

- trivalent catalytic converter (catalytic silencer);
- Lambda sensors;
- anti-evaporation system.

If one or more spark plugs are disconnected, do not run the engine, even for a test.

The devices used to reduce diesel fuel engine emissions are:

- oxidising catalyst;
- exhaust gas recirculation system (E. G. R.);
- diesel particulate filter (DPF).



During normal service the catalyst and the diesel particulate filter (DPF) reach high temperatures. Do not therefore park the car over inflammable materials (grass, dry leaves, pine needles, etc.): fire hazard.

DPF (Diesel Particulate Filter) (for versions/ markets where applicable)

The Diesel Particulate Filter is a mechanical filter, integral with the exhaust system, that physically traps particulates present in the exhaust gases of Diesel engines.

The diesel particulate filter has been adopted to eliminate almost totally particulates in compliance with current / future law regulations.



During normal use of the car, the engine control unit records a set of data (e.g.: travel time, type of route, temperatures, etc.) and it will then calculate how much particulates has been trapped by the filter.

Since this filter physically traps particulates, it shall be cleaned (reclaimed) at regular intervals by burning carbon particles.

Reclaiming procedure is controlled automatically by the engine control unit according to the filter conditions and the conditions of use of the car. During reclaiming the following phenomena could take place: idling slight increase, fan activation, slight smoke increase, high exhaust temperatures.

These situations shall not be considered as faults and they do not affect car performance and environment.

Diesel Particulate Filter clogged

When the diesel particulate filter is clogged, the display shows symbol  + message. In this event keep the engine running until symbol  and message turn off.

CORRECT USE OF THE CAR

STARTING THE ENGINE

IMPORTANT The car is fitted with an electronic engine lock device. If the engine fails to start, see the "Alfa Romeo CODE system".



We recommend that during the initial period you do not drive to full car performance (for example excessive acceleration, long journeys at top speed, hard braking etc.).



Running the engine in confined areas is extremely dangerous. The engine consumes oxygen and produces carbon monoxide which is a highly toxic and lethal gas.

The ignition switch is fitted with a safety device which obliges the driver to return the key to the **STOP** position before repeating the starting operation if the engine does not start immediately.

Similarly, when the engine is running, the device prevents the key being moved from the **MAR** to the **AVV** position.



When the engine is switched off never leave the ignition key in the **MAR** position to prevent pointless current absorption from draining the battery.



STARTING PROCEDURE FOR PETROL VERSIONS

IMPORTANT It is important never to press the accelerator before the engine has started.

- 1) Make sure the handbrake is engaged.
- 2) Move the gear lever to neutral.
- 3) Fully depress the clutch pedal, so that the starter motor is not forced to crank the gears.
- 4) Ensure that the electric systems and devices, especially if they absorb high quantities of energy (e.g. heated rearscreen), are switched off.
- 5) Turn the ignition key to the **AVV** position and release it as soon as the engine starts.
- 6) If the engine does not start, return the key to **STOP**, then repeat the procedure.

IMPORTANT If it is difficult to start the engine do not insist with extended attempts which may damage the catalyst, but contact Alfa Romeo Authorised Services.

STARTING PROCEDURE FOR JTD VERSIONS

- 1) Make sure the handbrake is engaged.
- 2) Set the gearshift lever to neutral.
- 3) Turn the ignition key to **MAR**. The reconfigurable multifunction display will show the  warning light.
4) Wait for the  to turn off, which takes place sooner, the warmer the engine. With the engine very warm the light might stay on for such a short time as to pass unnoticed.
- 5) Fully depress the clutch pedal.
- 6) Turn the ignition key to **AVV** as soon as the  warning light has gone out. Waiting too long, makes the warming work of the glow plugs useless.

IMPORTANT The electric devices that absorb a high amount of energy (climate control, rearscreen heating, etc.) are cut off automatically during starting.

If the engine does not start at the first attempt, move the ignition key to **STOP** before repeating starting.

If starting is difficult (with the Alfa Romeo CODE system working properly), do not insist with prolonged attempts.

Only use an auxiliary battery if the cause is due to low battery charge. Never use a battery charger to start the engine.

WARMING THE ENGINE

— Drive off slowly, at medium revs without accelerating abruptly.

— Do not drive at full performance for the initial kilometres of the journey. Wait until the engine coolant temperature reaches 50-60 °C.

ENGINE SWITCHING OFF

- Release the accelerator pedal and wait until the engine reaches idle speed.
- Turn the ignition key to the **STOP** position and switch off the engine.

IMPORTANT After a tiring journey it is advisable to let the engine “get its breath back” allowing it to idle a while to lower the temperature in the engine compartment.



For cars with turbocharger in particular, but for all cars in general, sharp accelerating should be avoided before switching the engine off.

A “kick” on the accelerator serves no purpose, consumes fuel pointlessly and may cause serious damage to the turbocharger impeller bearings.

IMPORTANT If the engine turns off with the car on the move, the next time it is started, the Alfa Romeo CODE warning light may turn on (🔒). In this case, check that switching off and starting the engine again with the car stationary, the warning light stays off. If not, contact Alfa Romeo Authorised Services.

EMERGENCY STARTING

If the Alfa Romeo CODE system does not recognise the code transmitted by the ignition key (warning light 🔒 on the instrument cluster glowing on steadily) emergency starting may be carried out using the code of the CODE card.

For the correct procedure see the chapter “In an emergency”.



Never push, tow or coast start the car. This could cause fuel to flow into the catalyst damaging it irreversibly.



Remember that the engine brake and power steering are not operational until the engine is started, therefore, much greater effort than usual is needed on the brake pedal and steering wheel.

PARKING

When the car is parked, proceed as follows:

- Switch off the engine.
- Engage the handbrake.
- Engage first gear if the car is faced uphill or reverse if the car is facing downhill.
- Turn the front wheels so that the car will immediately come to a halt if the handbrake slips.



To avoid useless consumption of power and possible draining of the battery, never leave the ignition key in the MAR position when the engine is not running.



Never leave children unattended in the car. Always remove the ignition key when leaving the car and take it with you.

REDUCING RUNNING COSTS AND ENVIRONMENT POLLUTION

By following a few simple guidelines, it is possible to save car running costs and reduce harmful emissions.

GENERAL CONSIDERATIONS

Car maintenance

To take care of the car maintenance have the checks and adjustments carried out in accordance with the “Scheduled Maintenance Programme”.

Tyres

Check the pressure of the tyres routinely at an interval of no more than 4 weeks: if the pressure is too low consumption levels increase as resistance to rolling is higher.

Useless loads

Never travel with an overload in the boot. The weight of the car (especially in urban traffic), and its geometry heavily affect consumption levels and stability.

Electric services

Use electric devices only for the amount of time needed. Rearscreen heating, additional headlights, windscreen wipers and heater fan need a considerable amount of energy, therefore increasing the requirement of current increases fuel consumption (up to +25% in the urban cycle).

Climate control system

The climate control system is a further load bearing heavily on the engine inducing higher consumption levels (up to +20% on average). Outside temperature permitting, preferably use the air vents.

Aerodynamic items

The use of non-certified aerodynamic items may adversely affect air drag and consumption levels.

DRIVING STYLE

Starting

Do not warm the engine with the car at a standstill or at idle or high speed: under these conditions the engine warms up much more slowly, increasing electrical consumption and emissions. It is therefore advisable to move off immediately, slowly, avoiding high speeds. This way the engine will warm faster.

Pointless manoeuvres

Avoid accelerating when waiting at traffic lights or before switching off the engine. This and also double declutching is absolutely pointless on modern cars and also increase consumption and pollution.

Gearshifting

As soon as the conditions of the traffic and road allow, use a higher gear.

Using a low gear to obtain brilliant performance increases consumption.

In the same way improper use of a high gear increases consumption, emissions and engine wear.

Top speed

Fuel consumption considerably increases with speed. Maintain an even as possible speed, avoiding superfluous braking and accelerating, which cost in terms of both fuel and emissions.

Acceleration

Accelerating heavily taking the engine to a high speed has a considerably adverse effect on consumption and emission levels; it is wise to accelerate gradually and not exceed the maximum torque.

CONDITIONS OF USE

Cold starting

Short journeys and frequent cold starts do not allow the engine to reach optimum operating temperature. This results in a significant increase in consumption levels (from +15 to +30% on the urban cycle) and emission of harmful substances.

Traffic situations and road conditions

Rather high consumption levels are tied to situations with heavy traffic, for example in queues with frequent use of the lower gears or in cities with many traffic lights. Also winding mounting roads and rough road surfaces adversely affect consumption.

Stopping in the traffic

During prolonged stops (e.g. level crossings) it is advisable to switch the engine off.

TOWING TRAILERS

IMPORTANT NOTES

For towing caravans or trailers the car must be fitted with a certified tow hook and an adequate electric system. Installation should be carried out by specialised personnel who release a special document for circulation on the road.

Install any specific and/or additional rearview mirrors as specified by law. Remember that when towing a trailer, steep hills are harder to climb, the braking spaces increase and overtaking takes longer depending on the overall weight.

Engage a lower gear when driving downhill, rather than constantly using the brake.

The weight the trailer exerts on the car tow hook reduces by the same amount the actual car loading capacity.

To make sure the maximum towable weight is not exceeded (given in the log book) account should be taken of the fully laden trailer, including accessories and personal belongings.

Drive within the specific speed limit in every country for car trailers. In any case the maximum speed should never exceed 100 km/h.



The ABS system with which the car may be fitted does not control the trailer braking system. Particular care is therefore necessary on slippery surfaces.



Under no circumstances should the car brake system be altered to control the trailer brake. The trailer braking system must be fully independent of the car's hydraulic system.

INSTALLING THE TOW HOOK

The towing device should be fastened to the body by specialised personnel according to the following instructions and any additional and/or integrative information supplied by the Manufacturer of the device itself.

The towing device must meet current regulations with reference to Directive 94/20/CEE and subsequent amendments.

For any version the towing device used must match the towable weight of the car on which it is to be installed.

For the electric connection a unified connector should be used which is generally placed on a special bracket normally fastened to the towing device itself.

For the electrical connection a 7 or 13 pole 12VDC connection must be used (CU-NA/UNI and ISO/DIN standards) following any reference instructions given by the car Manufacturer and/or towing device Manufacturer.

Any electric brake should be supplied directly by the battery through a cable with a cross-section of no less than 2.5 mm². In addition to the electrical branches, the car electric system can only be connected to the supply cable for an electric brake and to the cable for an internal light, though not above 15W.

INSTALLATION LAYOUT (fig. 1)

The tow hook structure must be fastened in the points shown by the symbol  using 4 M8 screws and 7 M10 screws.

The inner plate **(2)** should have a minimum thickness of 6 mm.

The inner plate **(3)** should have a minimum thickness of 4 mm.

The inner plate **(4)** should have a minimum thickness of 5 mm.

The fastening points **(1)** should be fitted with 25 mm x 6 mm spacers.



After fitting, the fastening screw holes shall be sealed to prevent exhaust gas inlet.

IMPORTANT It is compulsory to fasten a label (plainly visible) of suitable size and material with the following wording:

MAX LOAD ON BALL 60 kg.

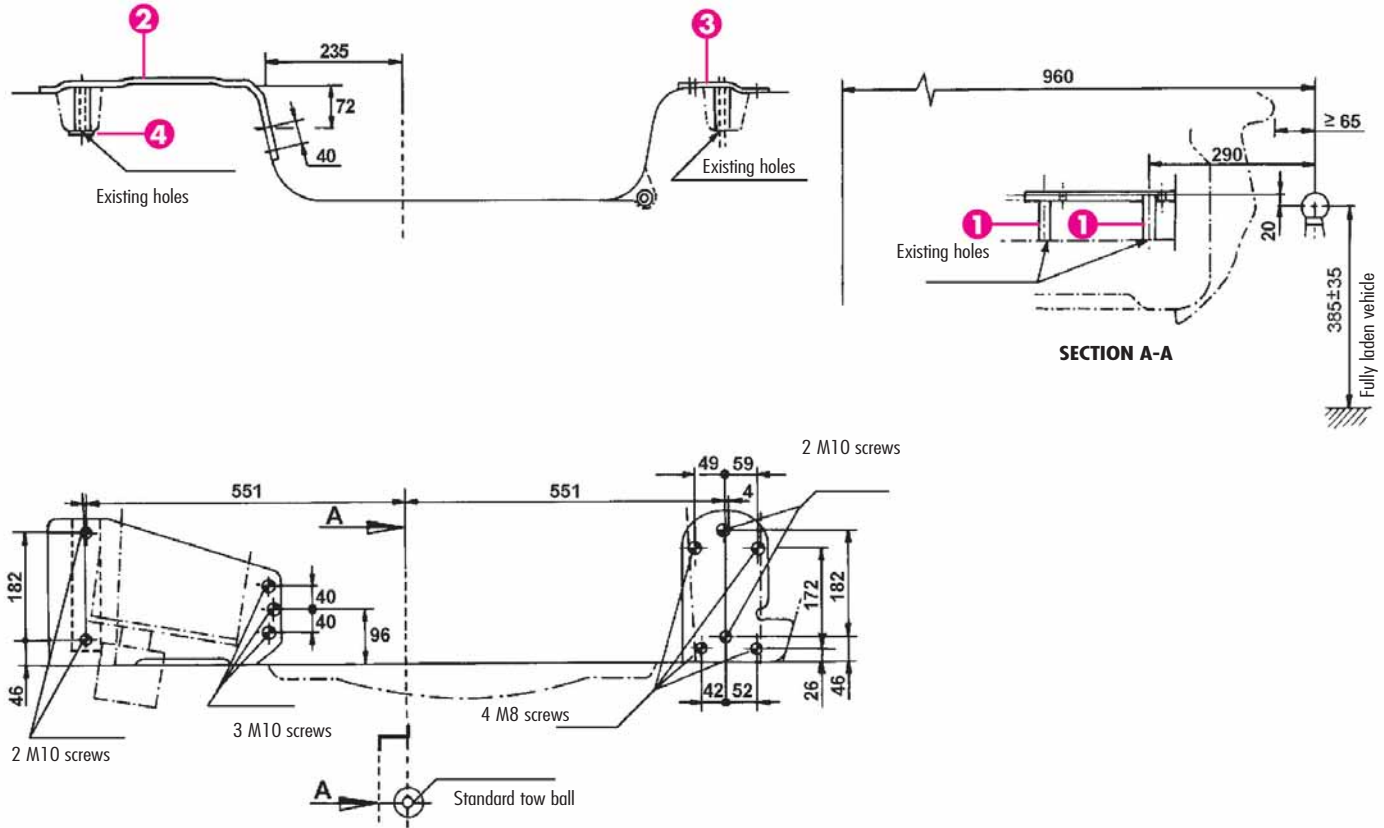

fig. 1

WINTER TYRES

These tyres are specially designed for driving on snow and ice, to be fitted in replacement of those fitted on the car.

Use winter tyres of the same size as normal tyres provided on the car.

Alfa Romeo Authorised Services will be pleased to advise you on the choice of the tyre most suited to the use the Customer intends to make of it.

For the type of tyre to be used, inflation pressures and specifications of winter tyres, follow the instructions given in the "Technical Specifications" chapter.

The winter features of these tyres are reduced considerably when the tread depth is below 4 mm. In this case, they should be replaced.

Due to the winter features, under normal conditions of use or long motorway journeys, the performance of these tyres is lower than that of normal tyres.

It is necessary therefore to limit their use to the purposes for which they are certified.

IMPORTANT When winter tyres are used with a maximum speed index below the one that can be reached by the car (increased by 5%), place a notice in the passenger's compartment, plainly in the driver's view, which states the maximum permissible speed of the winter tyres (as per EC Directive).

Fit the same type of tyre on all four wheels (brand and profile) to ensure higher driving safety when braking and good handling.

Remember that it is inappropriate to change the direction of rotation of tyres.

SNOW CHAINS

Use of snow chains should be in compliance with local regulations.

For 1.8 T, SPARK, 2.0 JTS and 1.9 JTD versions, tyre 195/60 R15 can be fitted with chains (use snow chains with reduced size with max protrusion beyond the tyre profile of 12 mm). Tyres 205/60 R15 - 205/55 R16 - 205/55 ZR16 - 215/45 R17 - 215/45 ZR17 - 225/40 ZR18 cannot be fitted with snow chains.

For 3.2 v6 version, only use spider type chains on tyres 215/45 R17" and 215/45 ZR 17". Tyres 225/45 ZR17 - 225/40 ZR18 cannot be fitted with snow chains.

Lineaccessori Alfa Romeo provides SPIKES SPIDER COMPACT chains (model: 17003 compact) with 9 spikes, 16 mm adjustable length and 17 inch wheel cap adapter.

Snow chains should only be applied to the drive wheels (front).

Before purchasing or using snow chains, you are recommended to contact Alfa Romeo Authorised Services.

Check the tensions of the chain after the first few metres have been driven.



Deactivate the ASR system when snow chains are fitted. Press the ASR-OFF button, button led turned on.



Snow chains cannot be fitted to the space-saver spare wheel. So, if a front (drive) wheel is punctured and chains are needed, a rear wheel should be fitted to the front of the car (adjust tyre pressure to the specified value as soon as possible) and the space-saver spare wheel should be fitted to the rear. This way with two normal drive wheels, snow chains can be fitted to them to solve an emergency.



Keep your speed down when snow chains are fitted. Do not exceed 50 km/h. Avoid potholes, steps and pavements and avoid also to drive for long distances on roads not covered with snow to prevent damaging the car and the roadbed.

CAR INACTIVITY

If the car is to be left inactive for long periods, the following precautions should be noted:

- House the car under cover in a dry and possibly ventilated place.
- Engage a gear.
- Check that the handbrake is not engaged.
- Clean and protect the paintwork by protective wax.
- Clean and protect the metal polished parts with marketed products.
- Cover the rubber windscreen and rearscreen wiper blades with talcum powder and raise them off the glass.
- Open the windows slightly.
- Inflate the tyres to a pressure of 0.5 bars above normal. If possible rest the tyres on wooden planks and periodically check the pressure.
- Do not turn on the electronic alarm system.

– Disconnect the battery negative terminal from the battery and check the battery charge. This check should be repeated every three months during stowage. Charge the battery if the indicator (where provided) shows a dark colour in the central green area.



– Do not empty the engine cooling system.

– Cover the car with a fabric or perforated plastic cover. Do not use compact plastic covers which prevent the humidity on the surface of the car from evaporating.

IN AN EMERGENCY

In an emergency we recommend that you call the freephone number found in the Warranty Booklet. You can also consult www.alfaromeo.com to find Alfa Romeo Authorised Services your nearest

EMERGENCY STARTING



If it is not possible to deactivate the engine inhibitor with the Alfa Romeo CODE system, the  and  warning lights stay on and the engine will not start. Emergency starting is needed to start the engine.

IMPORTANT You are advised to carefully read the entire procedure before carrying it out. If a mistake is made during the emergency procedure, the ignition key should be turned to **STOP** and the operations must be repeated from the start (point 1).

1) Read the 5-figure electronic code on the CODE card.

2) Turn the ignition key to **MAR**.

3) Fully depress the accelerator pedal and keep it pressed. The  warning light will come on for eight seconds and then go off, now release the accelerator pedal.

4) The  warning light begins to flash: after it has flashed the same number of times as the first digit on the CODE card, press the accelerator pedal and keep it pressed until the  warning light turns on (for four seconds) and then goes off; now release the accelerator pedal.

5) The  warning light starts to flash: after the number of flashes corresponding to the second digit on the CODE card, press the accelerator pedal and keep it pressed.

6) Repeat this procedure for the remaining digits on the CODE card.

7) After entering the last figure, keep the accelerator pedal pressed. The  warning light turns on (for four seconds) and then goes off; now release the accelerator pedal.

8) A quick flash of the  warning light (for about four seconds) confirms that the operation has been carried out correctly.

9) Start the engine turning the ignition key from **MAR** to **AVV** without returning the key to the **STOP** position.

Conversely, if the  warning light stays on, turn the key to **STOP** and repeat the procedure starting from point 1).

IMPORTANT After emergency starting it is advisable to contact Alfa Romeo Authorised Services, because the emergency procedure must be repeated each time the engine is started.

STARTING WITH AN AUXILIARY BATTERY

If the battery is flat (for battery with optical hydrometer: dark colour without green area in the centre), it is possible to start the engine using an auxiliary battery with the same capacity or a little higher than the flat one.

Proceed as follows (**fig. 1**):

1) Remove the protective cover on the positive battery post pressing on the opening catches (front), then connect the positive terminals (+ sign next to the terminal) of the two batteries using a special cable.

2) Connect the end of the second jump lead to the negative terminal (−) of the auxiliary battery with an earth point ↓ on the engine or gearbox of the car to be started.

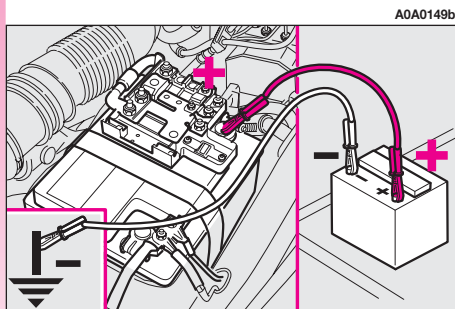

fig. 1

IMPORTANT Do not directly connect the negative terminals of the two batteries: any sparks may ignite the detonating gas which could come out of the battery. If the auxiliary battery is installed on another car, avoid metal parts touching accidentally between this car and the one with the flat battery.

3) Start the engine.

4) When the engine has started, remove the cables, reversing the sequence followed for connection.

If after a few attempts the engine does not start, do not insist but contact the nearest Alfa Romeo Authorised Service.



This starting procedure **must be carried out by qualified personnel because incorrect operations may cause electrical discharge of considerable intensity. The liquid contained in the battery is poisonous and corrosive. Avoid contact with the skin and the eyes. Keep naked flames and lighted cigarettes away from the battery and do not cause sparks.**



Never use a battery charger to start the engine as this could damage the electronic systems of your car, particularly the ignition and fuel supply control units.

STARTING BY INERTIA



Never push, tow or coast start the car. This could cause fuel to flow into the catalyst damaging it irreversibly.



Remember that the engine brake and power steering are not operational until the engine is started, therefore, much greater effort than usual is needed on the brake pedal and steering wheel.

IN THE EVENT OF A PUNCTURE

If the car is equipped with “Kit for tyre repair Fix&Go”, see the instructions contained in the following chapter.

GENERAL INSTRUCTIONS

As an alternative to the FIX & GO, the car can be provided (upon request) with space-saver spare wheel or standard wheel; wheel changing and correct use of the jack call for some precautions as listed below.



Signal the presence of the stationary car according to current regulations: hazard warning lights, reflecting triangle etc.. Any passengers should leave the car and wait for the wheel to be changed out of harm of the traffic.

If parked on a slope or rough surface, chock the wheels with wedges or other suitable devices to prevent the car from rolling.



Never start the engine with the car jacked.

When driving with a trailer, disconnect the trailer before raising the car. The compact spare wheel is specific to your car, do not use it on other models, or use the spare wheel of other models on your car.

Should the type of wheels used be changed (alloy rims instead of steel), it is also necessary to change the whole set of fastening bolts with others of suitable size.

The compact spare wheel is narrower than normal wheels, it should be used only for the distance necessary to reach a service point to have the punctured tyre repaired and, during its use, the car speed must not exceed 80 km/h.



The spare wheel has a sticker that summarises the main cautions for use and limitations. The sticker should never be removed or covered. The sticker contains the following in four languages:

CAUTION! FOR TEMPORARY USE ONLY! MAX 80 km/h! REPLACE BY NORMAL WHEEL AS SOON AS POSSIBLE. DO NOT COVER THIS LABEL IN USE.

Never fit a wheel cap on a compact spare wheel.

The car will handle differently with the spare wheel fitted: avoid heavy braking and accelerating, sharp corners and fast bends.



The life of the spare wheel is approx. 3000 km, after this distance it should be replaced with another of the same type.

Never attempt to fit a conventional tyre on a rim designed for use as a compact spare wheel. Have the punctured wheel repaired and refitted as soon as possible.

Two or more compact spare wheels should never be used together.

Do not grease the threads of bolts before installing them; they might slip out.

The jack only serves for changing wheels on the car with which it is provided or on cars of the same model. It must not be used for other purposes such as for instance raising cars of other models. In no case should it be used for repairs under the car.

Incorrect positioning of the jack may cause the jacked car to fall.

Do not use the jack for higher capacities than stated on its label.



Snow chains cannot be fitted on the compact spare wheel, so, if a front wheel is punctured and chains need to be used, the front axle should be fitted with normal wheels and the compact spare wheel fitted to the rear. This way, with two normal wheels at the front, snow chains can be fitted thereby solving the emergency situation.

Never tamper with the inflation valve.

Do not insert tools of any kind between the rim and the tyre.

Check, and if necessary, restore the pressure of the tyres and of the compact spare wheel to the values given in the "Technical Specifications" chapter.

CHANGING A WHEEL

Please be informed that:

- the jack mass is 2.100 kg.
- the jack requires no adjustment.
- the jack cannot be repaired. In the event of breakage, it must be replaced by another original one.
- no tools other than its operating crank can be fitted to the jack.

To change a wheel, proceed as follows:

- Stop the car in such a position that it is not dangerous for the traffic, where it is possible to change the wheel safely. Where possible, park on a level, compact surface.
- Switch off the engine and engage the handbrake.
- Engage first gear or reverse.

- Use handle **(A-fig.2)** to remove the stiff covering **(B)**.
- Loosen the clamping device **(A-fig. 3)**.
- Take out the tool container **(B)** and take it near the wheel to be changed.
- Take the spare wheel **(C)**.
- Remove the wheel cap **(A-fig. 4)** (only versions with steel rims)

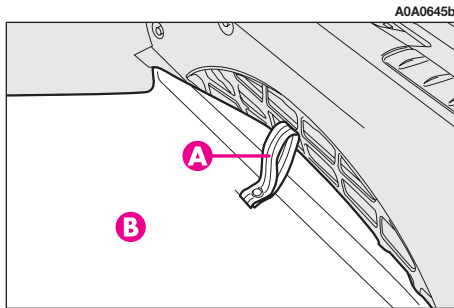

fig. 2

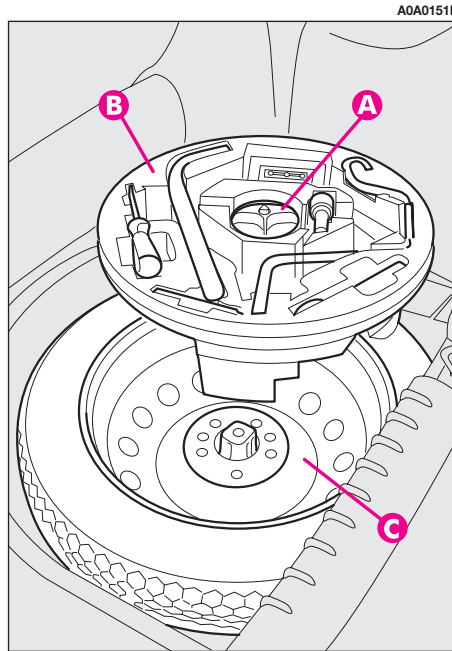

fig. 3

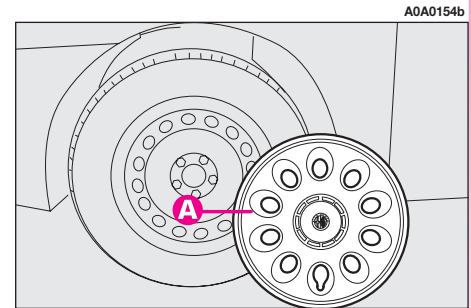

fig. 4

– Using the wrench provided (**A-fig. 5**), loosen the fastening bolts by about one turn.

– Set the jack under the car, near the wheel to be changed taking care not to damage the plastic streamlined guard.

– Work the jack crank (**A-fig. 6**), to extend it until the groove (**B**) on the upper part of jack is correctly inserted on the lower profile of the body (**C**) approx. 40 cm from the profile of the wheelhouse.

– Work the jack and raise the car until the wheel is a few centimetres from the ground.

– Completely unscrew the fastening bolts and remove the wheel.

– Make sure that the contact surfaces of the spare wheel with the hub are clean and free of impurities which may later cause the fastening bolts to slacken.

– Install the spare wheel matching the hole (**A-fig. 7**) with the corresponding pin (**B**).

– Using the wrench provided, fasten the five bolts.

– Lower the car and remove the jack.

– Using the wrench provided, fully tighten the bolts in the sequence shown in **fig. 8**.

REFITTING A NORMAL WHEEL

– Following the procedure described previously, raise the car and remove the spare wheel.

For versions with steel rims:

– Fit the normal wheel matching the hole (**A-fig. 7**) with the corresponding pin (**B**).

– Make sure that the contact surfaces of the wheel with the hub are clean and free of impurities which may later cause the fastening bolts to slacken.

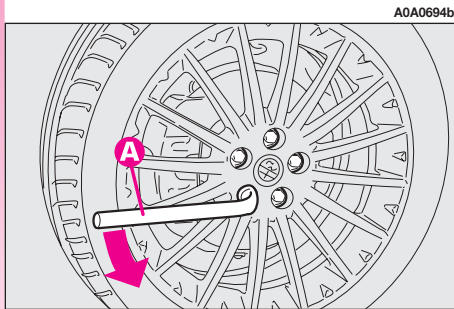

fig. 5

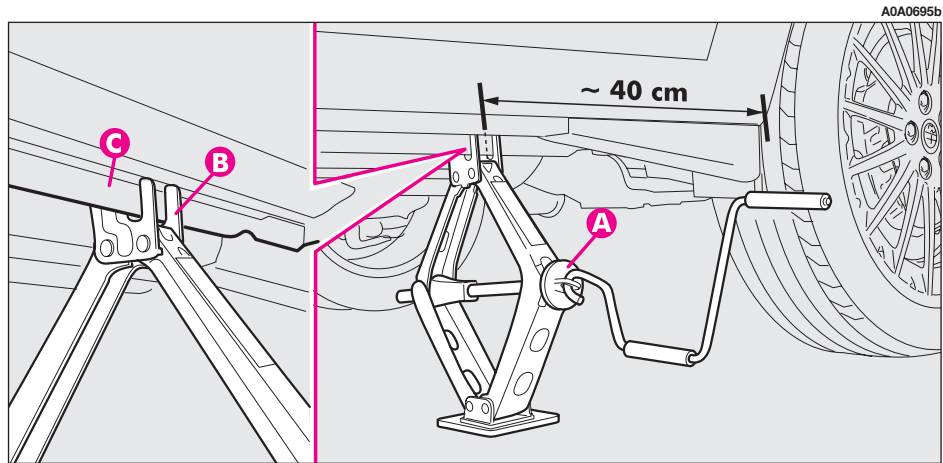

fig. 6

– Using the wrench provided, tighten the fastening bolts.

– Lower the car and remove the jack.

– Using the wrench provided, fully tighten the bolts in the sequence shown previously for the compact spare wheel **fig. 8**.

– Place the cap near the wheel so that the inflation valve can come through the slot provided on the cap.

– Press the circumference of the cap, starting from the parts nearest to the inflation valve until it is inserted completely.

IMPORTANT Incorrect fitting may cause the wheel cap to come off when the car is travelling.

For versions with alloy rims:

– Tighten the pin (**A-fig. 9**) in one of the fastening bolt holes on the wheel hub.

– Insert the wheel on the pin and, using the wrench provided, tighten the four bolts available. This is facilitated by the extension provided (**B**).

– Remove the pin (**A-fig. 9**) and tighten the last fastening bolt.

– Lower the car and remove the jack.

– Using the wrench provided, tighten the bolts in the sequence shown previously for the compact spare wheel **fig. 8**.

After refitting a wheel:

– stow the spare wheel in the space provided in the boot

– insert the jack in its container forcing it lightly to prevent it from vibrating when travelling

– place the tools used in the housings in the container

– stow the container complete with tools on the spare wheel and secure everything with the clamping device (**A-fig. 3**)

– correctly re-position the stiff cover.

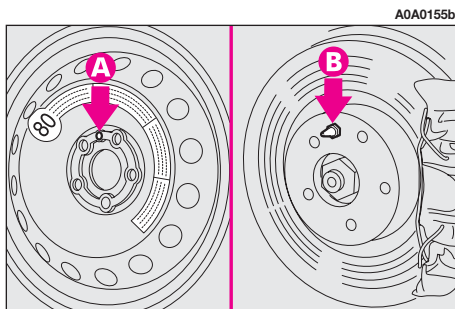

fig. 7

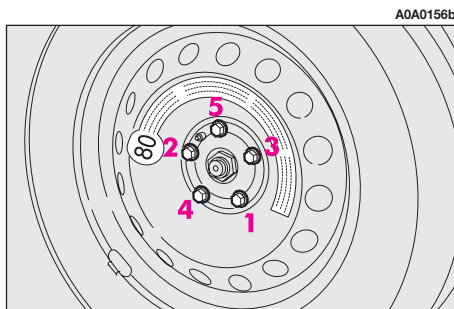

fig. 8

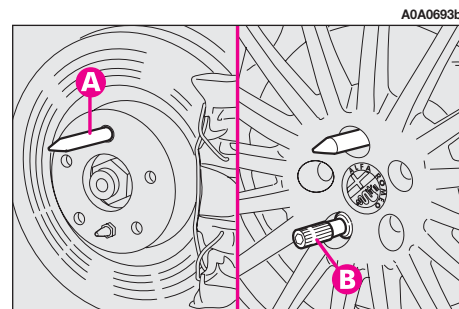

fig. 9

QUICK TYRE REPAIR KIT FIX&GO automatic

The car is equipped with a tyre quick repairing kit called "FIX&GO automatic", replacing the tools and the compact spare wheel usually provided with the car.

The kit **fig. 10** is placed in the boot. In the kit container you will also find the screw-driver and the tow ring.

The quick tyre repair kit includes:

- bottle **A-fig. 10** containing sealer and fitted with:
- filler hose **B**
- sticker **C** with caution "max. 80 km/h", to be affixed in a visible position for the driver (instrument panel) after repairing the tyre;
- compressor **D** including gauge and connections;

– instruction brochure **fig. 11**, to be used for prompt and proper use of the quick repair kit and to be then handed to the personnel charged with handling the treated tyre;

- a pair of protection gloves located in the side space of the compressor;
- adapters for inflating different elements.

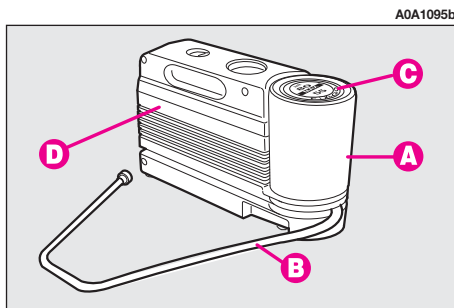

fig. 10

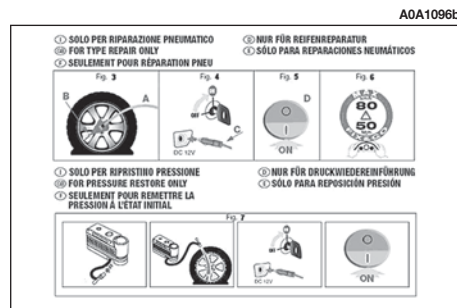

fig. 11



Hand the instruction brochure to the personnel charged with treating the tyre repaired with the kit.



In the event of a puncture caused by foreign bodies, it is possible to repair tyres showing damages on the track or shoulder up to max 4 mm diameter.

IT SHOULD BE NOTICED THAT:

The sealing fluid of the quick tyre repair kit is effective with external temperatures between -20°C and $+50^{\circ}\text{C}$. The sealing fluid has limited life.



Holes and damages on the tyre side walls cannot be repaired. Do not use the quick tyre repair kit if damaging is due to running with flat tyre.



Repairs are not possible in case of damages on the wheel rim (bad groove distortion causing air loss). Do not remove foreign bodies (screws or nails) from the tyre.



The cylinder contains ethylene glycol. The cylinder contains latex: it can cause allergic reactions. It is harmful if ingested or inhaled and irritant for the eyes and in case of contact. In case of contact rinse immediately with water and take off contaminated clothes. If swallowed, do not induce vomit, rinse out the mouth, drink a lot of water and call the doctor immediately. Keep away from children. This product must not be used by asthmatics. Do not inhale vapours. Call the doctor immediately in case of allergic reactions. Keep the cylinder in the space provided for the purpose and far from heat. The sealing fluid has limited life.



The compressor shall not be operated for more than 20 minutes. Risk of overheating!. Tyres repaired with the quick tyre repair kit shall be used temporarily only.



Replace the cylinder if sealer has run out. Do not throw away the cylinder and the sealing fluid. Have the sealing fluid and the cylinder disposed of in compliance with national and local regulations.

INFLATING PROCEDURE



Put on the protection gloves provided together with quick tyre repair kit.

Proceed as follows:

— place the wheel with the valve **A-fig. 13** in the position shown in the figure then, **pull up the handbrake**, take the repair kit and put it on the ground near the involved wheel;

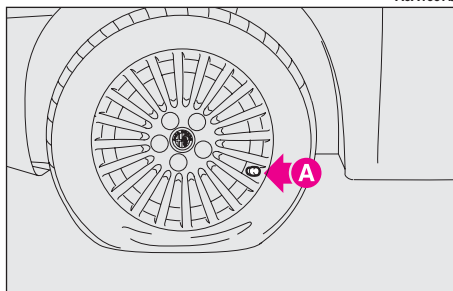

fig. 13

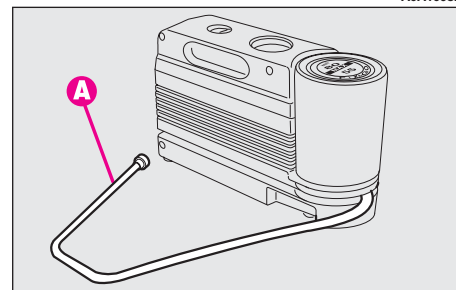

fig. 14

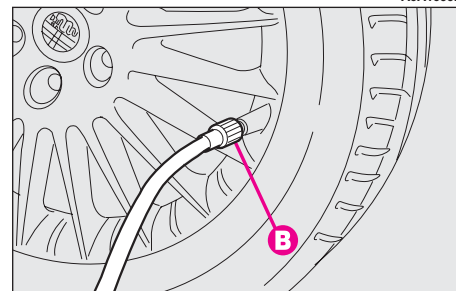

fig. 15

— loosen tyre inflation valve cap, take out the filler hose **A-fig. 14** and screw the ring nut **B-fig. 15** on the tyre valve;

A0A1098b

A0A1097b

A0A1099b

– make sure the compressor switch **A-fig. 16** is set to **0** (off), start the engine and fit plug **A-fig. 17** into the cigar lighter outlet and then turn on the compressor by setting switch **A-fig. 16** to **I** (on);

– inflate the tyre to the correct pressure value. Check tyre pressure on gauge **B-fig. 16** with compressor off to obtain precise reading;

– if after 5 minutes it is still impossible to reach at least 1.5 bar, disengage compressor from valve and current outlet, then move the car forth for approx. ten metres in order to distribute the sealing fluid inside the tyre evenly, then repeat the inflation operation;

– if after this operation it is still impossible after 5 minutes to reach at least 1.8 bar, do not start driving since the tyre is excessively damaged and the quick tyre repair kit cannot guarantee suitable sealing, contact Alfa Romeo Authorized Services;

– once the correct tyre pressure has been reached, start driving immediately;

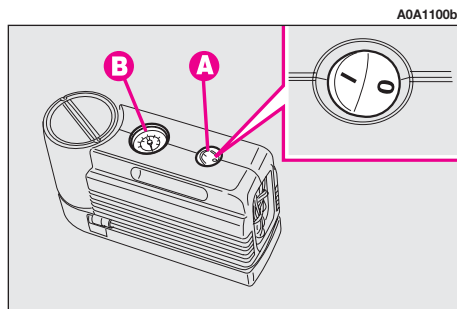

fig. 16

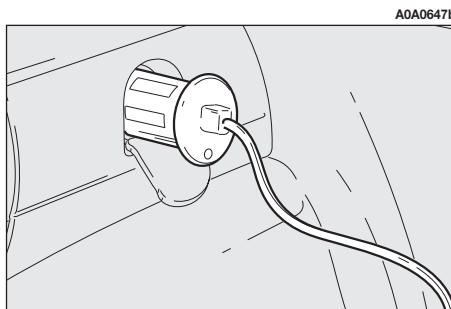

fig. 17



Apply the sticker in a visible position for the driver to indicate that the tyre has been treated with the quick tyre repair kit. Drive carefully especially when cornering. Do not exceed 80 km/h. Avoid heavy braking and accelerating.

– after driving for about 10 minutes stop and check again the tyre pressure; pull up the handbrake;



If the pressure falls below 1.8 bars, do not drive any further: the quick tyre repair kit Fix & Go automatic cannot guarantee proper hold because the tyre is too much damaged. Contact Alfa Romeo Authorized Services.

– if at least 1.8 bar pressure is read, restore proper pressure (with engine running and handbrake on) and restart;

– drive with the utmost care to the nearest Alfa Romeo Authorized Service.



It is of vital importance to communicate that the tyre has been repaired using the quick tyre repair kit. Hand the instruction brochure to the personnel charged with treating the tyre repaired with the kit.

FOR CHECKING AND RESTORING PRESSURE ONLY

The compressor can be also used just for restoring pressure. Disconnect the quick connection **A-fig. 18** and connect it directly to the tyre valve **fig. 19**; in this way the cylinder is not connected to compressor and the sealing fluid will not flow into the tyre.

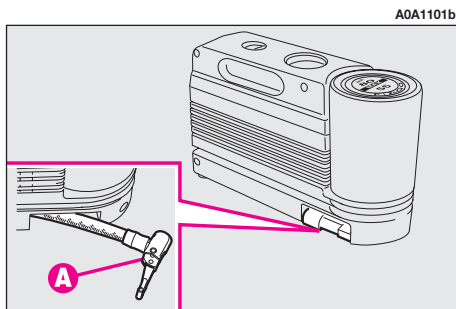

fig. 18

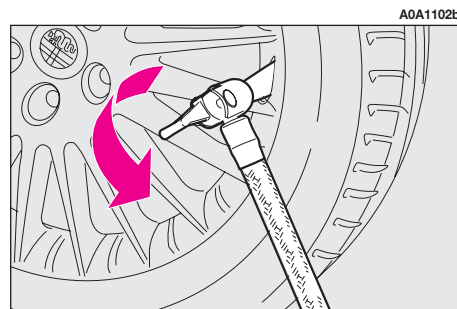

fig. 19

CYLINDER REPLACEMENT PROCEDURE

- To replace the cylinder proceed as follows:
- disconnect connection **A**-fig. 20 and hose **B**;
 - turn counter-clockwise the cylinder to replace and raise it;

- fit the new cylinder and turn it clockwise;
- reconnect connection **A** or hose **B** into the proper space.



It is of vital importance to communicate that the tyre has been repaired using the quick tyre repair kit. Hand the instruction sticker to the personnel charged with treating the tyre repaired with the kit.

A0A01103b

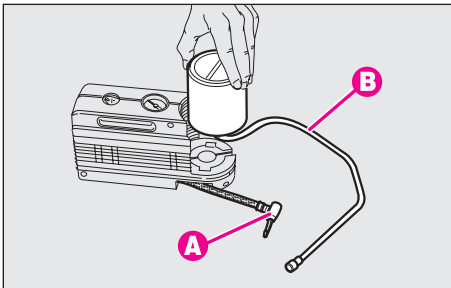

fig. 20

WHEN NEEDING TO CHANGE A BULB



Alterations or repairs to the electric system not carried out correctly and without taking into account the specifications of the system may cause malfunctioning and the risk of fire.



Where possible the bulbs should be replaced by Alfa Romeo Authorized Services. The correct operation and positioning of the external lights are vital to the safety of the car and its passengers and the subject of specific laws.



Due to high voltage, the bulb of (Xenon) gas-discharge headlights must only be replaced by experts: danger of death! Contact Alfa Romeo Authorized Services.



Halogen bulbs contain pressurised gas which, if broken, may cause small fragments of glass to be projected outwards.



Halogen bulbs must be handled touching only the metallic part. If the transparent bulb is touched with the fingers, its lighting intensity is reduced and life of the bulb may be compromised. If touched accidentally, rub the bulb with a cloth moistened with alcohol and allow to dry.

GENERAL INSTRUCTIONS

— When a light is not working, check that the corresponding fuse is intact before changing a bulb.

— For the location of fuses, refer to the paragraph “In the event of a burnt fuse” in this chapter.

— Before changing a bulb check the contacts for oxidation.

— Burnt bulbs must be replaced by others of the same type and power.

— Always check headlight aiming after changing a bulb to ensure they are safe.

TYPES OF BULBS (fig. 21)

Various types of bulbs are fitted to your car:

A. All glass bulbs

These are pressed on. Pull to remove.

B. Bayonet type bulbs

Press the bulb, turn counter-clockwise to remove this type of bulb from its holder.

C. Tubular bulbs

Free them from their contacts to remove.

D.-E. Halogen bulbs

To remove, free it from the clip on its housing.

F. Gas-discharge bulbs (Xenon)

To remove the bulb, slacken the fastening ring nut and release the retaining ring.

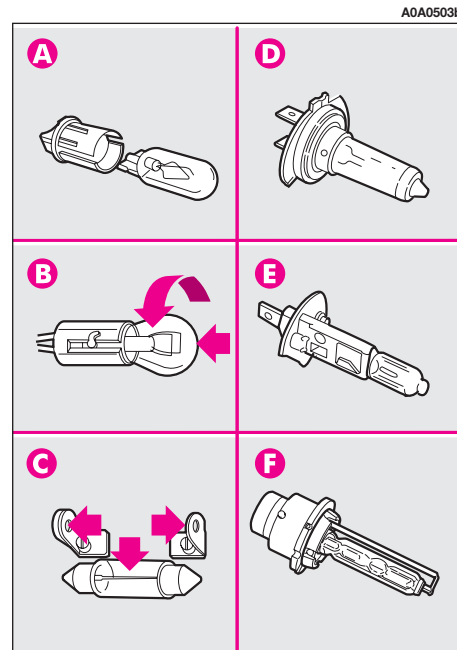

fig. 21

BULBS	FIGURE 21	TYPE	POWER
High beam	D	H7	55W
Low beam	D	H7	55W
Gas-discharge low beam headlights	F	DS2	35W
Front sidelights	B	H6W	6W
Foglights	E	H1	55W
Front direction indicators	B	PY21W	21W
Side direction indicators	A	W5W	5W
Rear direction indicators	B	P21W	21W
Rear sidelights - braking lights	B	P21/5W	5W/21W
Third stop (additional braking lights)	—	Led	—
Reversing light	B	P21W	21W
Rear foglights	B	P21W	21W
Number plate light	A	W5W	5W
Puddle lights	C	C5W	5W
Front roof light	C	C10W	10W
Rear roof light	C	C10W	10W
Courtesy mirror light	A	W1.2W	1.2W
Glovebox light	A	W5W	5W
Boot light	C	C5W	5W

IF AN EXTERIOR LIGHT GOES OUT

GAS-DISCHARGE (XENON) HEADLIGHTS



Due to high voltage, the bulb of (Xenon) gas-discharge headlights must only be replaced by experts: danger of death! Contact Alfa Romeo Authorized Services.

HALOGEN HEADLIGHTS

IMPORTANT For the type of bulb and power rating, see previous section “When needing to change a bulb”.

The front light units contain the sidelight, dipped beam, main beam and fog light bulbs.

The bulbs are arranged inside the light unit as follows (**fig. 22**):

- (A) Fog lights.
- (B) Dipped beam headlights.
- (C) Sidelights.
- (D) Main beam headlights.

To change the bulbs of the sidelights, low beams and main beams it is necessary to remove the cover (**A-fig. 23**) releasing the catches (**B**).

To change the fog lights, remove the cover (**C**) turning counter-clockwise.

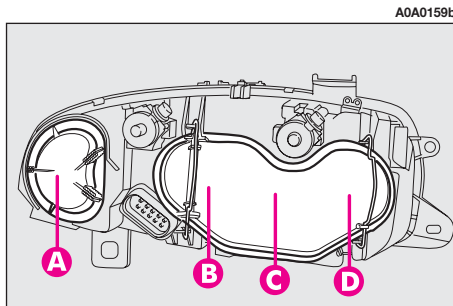

fig. 22

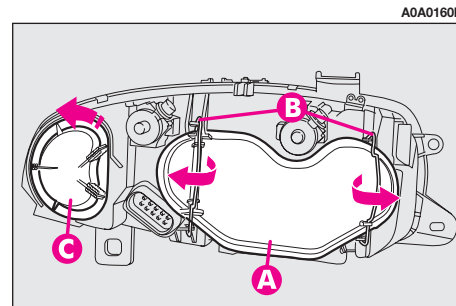

fig. 23



After replacement, refit the covers correctly checking that they are properly secured.

IMPORTANT A slight layer of steam (fogging) can appear on the inside surface of the beam transparent cover: this is not a defect. The presence of condensate traces in beams is a natural phenomenon, due to a low temperature and to the degree of humidity in the air. These traces will disappear when the beams are turned on. Drops of water inside the headlight indicate instead water infiltration: contact Alfa Romeo Authorised Services.

Fog lights (fig. 24)

IMPORTANT When needing to change the left bulb, the side trim next to the light itself needs to be removed to facilitate access to the engine compartment.

To change the bulb, proceed as follows:

- Remove the protective cover turning counter-clockwise.
- Disconnect the electric connector (**A**).
- Release the bulb catch (**B**).
- Remove the bulb and replace it.

- Fit a new bulb, making the tab of the metal part coincide with the one on the lamp unit, then hook the bulb holder catch (**B**).
- Re-connect the electric connector (**A**).
- Refit the protective cover correctly.

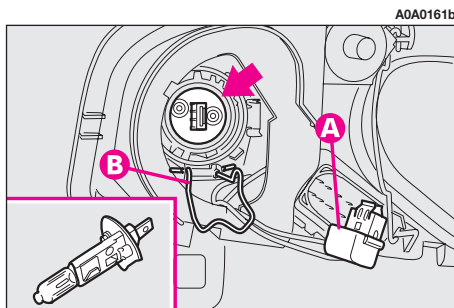

fig. 24

AQA0161b

Dipped beam headlights (fig. 25)

- To change the bulb, proceed as follows:
- Remove the protective cover releasing the catches.
 - Disconnect the electric connector (A).
 - Release the bulb catch (B).
 - Remove the bulb and replace it.
 - Fit a new bulb, making the tabs of the metallic part coincide with the grooves on the reflector, then hook the bulb holder catch (B).
 - Re-connect the electric connector (A).
 - Refit the protective cover correctly.

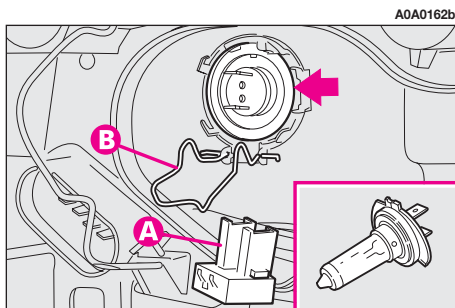

fig. 25

Front side lights (fig. 26)

- To change the bulb, proceed as follows:
- Remove the protective cover releasing the catches.
 - Using the extension (A), integral with the bulb holder (B), withdraw the bulb holder itself which is snap-fitted.
 - Remove the bulb (C), pushing gently and turning counter-clockwise.
 - Change the bulb and re-insert the bulb holder making sure that it clicks into place; also check that the bulb is in the correct position looking at the lamp from outside.
 - Refit the protective cover correctly.

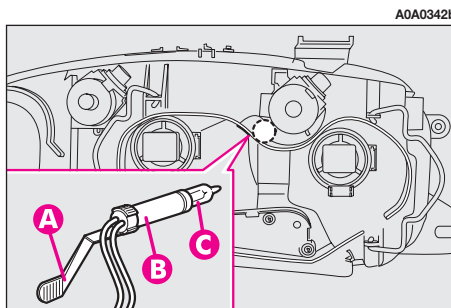

fig. 26

Main beam headlights (fig. 27)

- To change the bulb, proceed as follows:
- Remove the protective cover releasing the catches.
 - Disconnect the electric connector (A).
 - Release the bulb catch (B).
 - Remove the bulb and replace it.
 - Fit a new bulb, making the tabs of the metallic part coincide with the grooves on the reflector, then hook the bulb holder catch (B).
 - Re-connect the electric connector (A).
 - Refit the protective cover correctly.

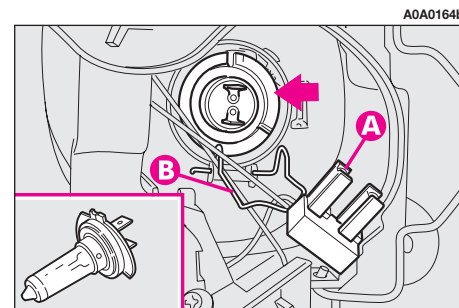

fig. 27

FRONT DIRECTION INDICATORS (fig. 28-29)

To change the bulb, proceed as follows:

- Using the screwdriver provided, remove the transparent unit operating on the two metal clips as shown in the figure;
- Turn the bulb holder clockwise (**A**) and remove it;
- Remove the bulb (**B**) pushing gently and turning counter-clockwise;

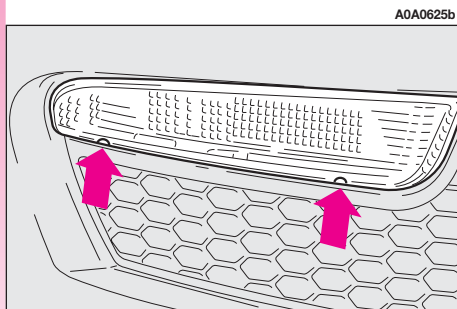

fig. 28

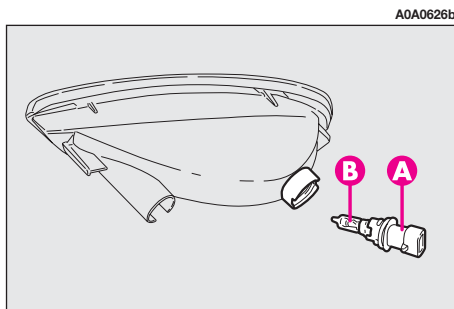

fig. 29

- Replace the bulb;
- Refit the bulb holder turning counter-clockwise and check that it is secured correctly;
- Refit the transparent.

SIDE DIRECTION INDICATORS (fig. 30)

– Push the transparent cover towards the rear of the car to compress the catch (**A**). Release the front part and remove this unit.

- Turn the bulb holder (**B**) counter-clockwise and remove it from the cover.
- Remove the snap-fitted bulb and replace it.
- Insert the bulb holder (**B**) in the transparent cover, then position the unit making sure the catch clicks into place (**A**).

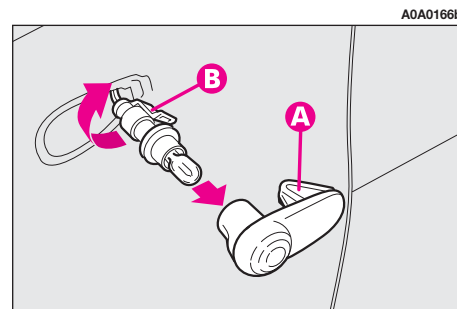

fig. 30

REVERSING LIGHT AND REAR FOG GUARDS (fig. 31-32)

The reverse light and the rear fog light (both reverse lights for Mexico version) are housed inside the light unit secured to the rear bumper and are located at the bottom side.

To change the bulb, proceed as follows:

- from the bumper lower side (**fig. 31**), operate on the bulb holder (**A-fig 32**) turning it counter-clockwise and remove it. Take care not to get burnt if the muffler is still hot;
- Remove the bulb pushing gently and turning counter-clockwise;
- Replace the bulb, then refit the bulb holder.

Anyway, you are advised to have this operation carried out by Alfa Romeo Authorised Services.

REAR DIRECTION INDICATORS AND REAR SIDELIGHTS- BRAKING LIGHTS (fig. 33-34)

The rear direction indicators and the side-lights-braking lights are in the tail light unit fastened to the body.

To change the bulb, proceed as follows:

- From inside the boot, open the compartment (**A-fig. 33**) and then the door (**B**) through the tab (**C**);
- Turn the bulb for sidelight and braking light counter-clockwise (**D-fig.34**), or the bulb for the direction indicator (**E-fig.34**) and remove it;

A0A0627b

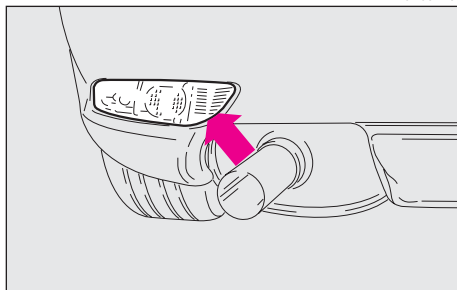

fig. 31

A0A0628b

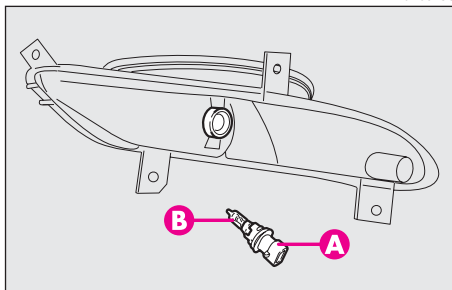

fig. 32

A0A0629b

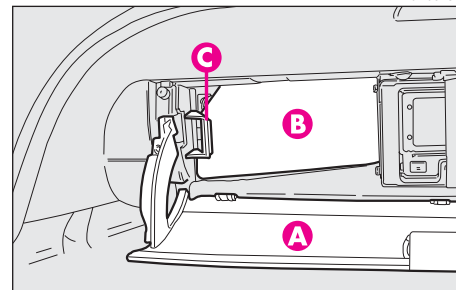

fig. 33

- Withdraw the light (**F** or **G**) push it gently and turn counter-clockwise;
- Replace the bulb;
- Refit the bulb holder turning clockwise and make sure it is secured correctly;
- Refit the door (**B**) and close the compartment (**A**).

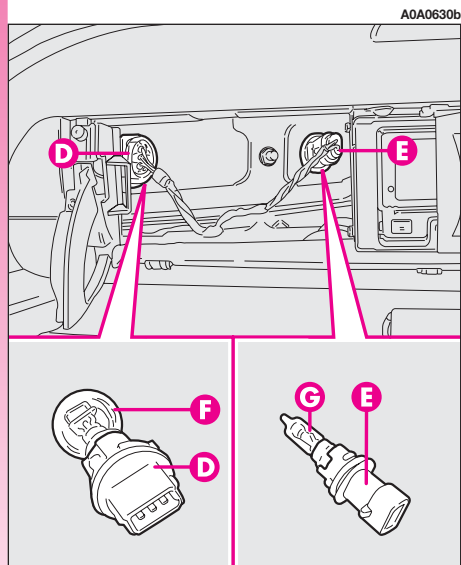

fig. 34

NUMBER PLATE LIGHTS (fig. 35)

To change the bulbs, proceed as follows:

- Work on the transparent cover frame, in the point shown by the arrow to compress the catch (**B**). Free the opposite end and remove the unit.
- Turn the bulb holder counter-clockwise (**A**) and remove it from the transparent cover.
- Remove the snap-fitted bulb and replace it.
- Insert the bulb holder (**A**) in the transparent cover then refit the unit checking that the catch clicks into place (**B**).

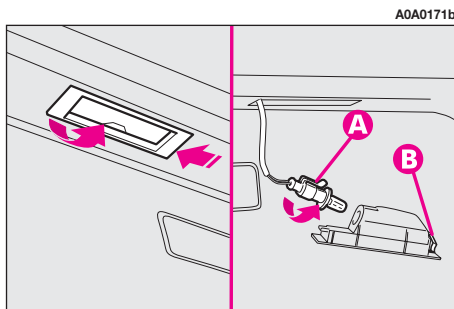

fig. 35

ADDITIONAL BRAKING LIGHT (THIRD STOP) (fig. 36-37)

To change the led unit, proceed as follows:

- Open the tailgate and use a screwdriver to open the two covers (**A**-fig. 36);
- Slacken the two fastening screws of (**B**) the led unit;

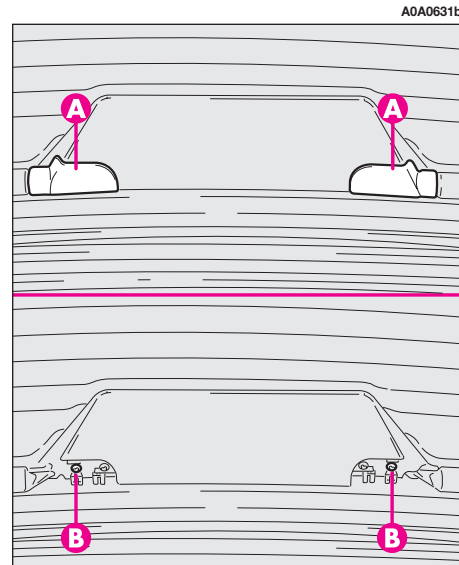

fig. 36

- disconnect the connector (**C**-fig. 37), remove the led unit (**D**) and replace it with a new unit;
- Refit the unit on the tailgate reversing the above mentioned procedure.

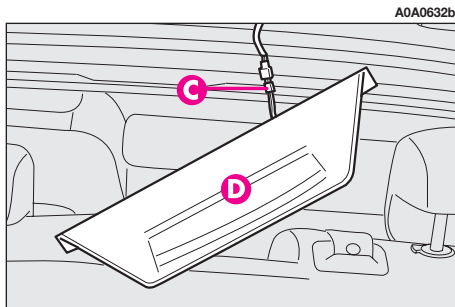

fig. 37

PUDDLE LIGHTS (fig. 38) (per versions/market where provided)

- To change the bulb, proceed as follows:
- Open the door and slacken the screw (**A**) fastening the transparent covers.
 - Remove the unit composed of the two transparent covers then change the bulb, releasing it from the side contacts making sure that the new bulb is correctly clamped between the contacts.
 - Realign the two transparent covers and tighten the fastening screw (**A**).

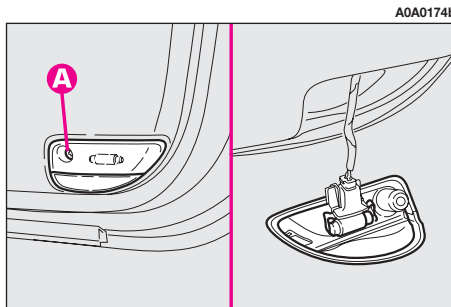

fig. 38

IF AN INTERIOR LIGHT GOES OUT

FRONT ROOF LIGHT (fig. 39-40)

- To change the bulbs, proceed as follows:
- Remove the light unit (**A**) levering in the points shown by the arrow (in correspondence with the retainer catches).
 - Open the protective cover (**B**).
 - Replace the bulb concerned releasing it from the side contacts making sure that the new bulb is correctly clamped between the contacts.

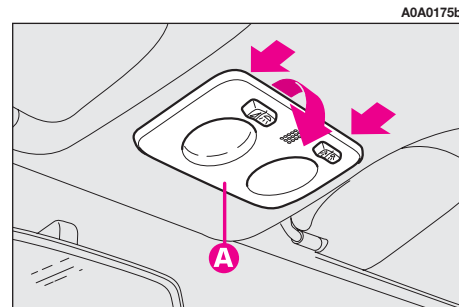

fig. 39

- Close the protective cover (**B**).
- Refit the light unit pressing gently in correspondence with the retainer catches, until hearing the click.

REAR ROOF LIGHT (fig. 41-42)

To change the bulb, proceed as follows:

- Remove the light unit (**A**) levering in the point shown by the arrow.
- Replace the bulb releasing it from the side contacts making sure that the new bulb is correctly clamped between the contacts.

- Refit the light unit in the correct position inserting first the side with the connector, then pressing the other side until the catch clicks into place (**B**).

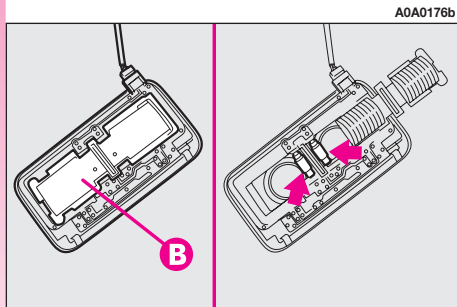

fig. 40

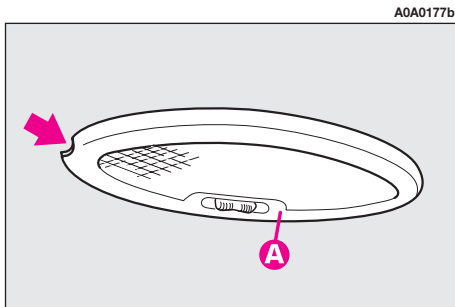

fig. 41

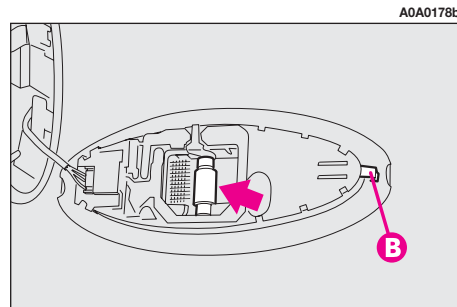

fig. 42

COURTESY MIRROR LIGHT (fig. 43-44)

To change the bulb, proceed as follows:

- Open the mirror cover (A).
- Remove the transparent cover (B) levering in the point shown by the arrow.
- Gently raise the bulb holder (C) from its housing, remove the snap-fitted bulb and change it.

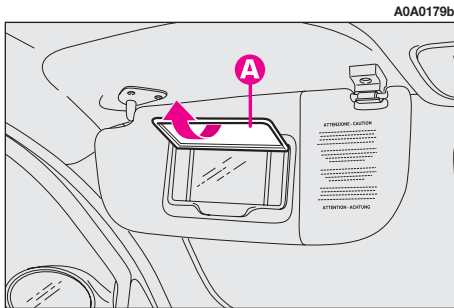

fig. 43

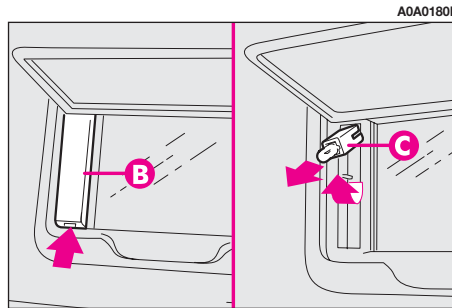

fig. 44

GLOVEBOX LIGHT (fig. 45-46)

To change the bulb, proceed as follows:

- Open the glovebox, then remove the light unit (A) levering in the point shown by the arrow.
- Open the protection (B) and change the snap-fitted bulb.
- Close the protection (B) on the transparent cover.

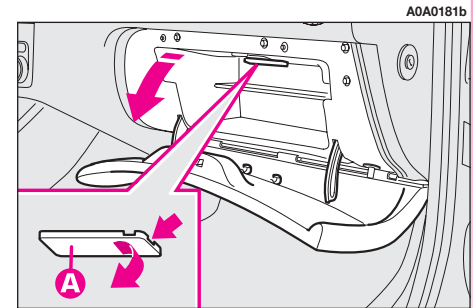

fig. 45

– Refit the light unit inserting it in its correct position firstly on one end and then on the other until it clicks into place.

BOOT LIGHT (fig. 47-48)

To change the bulb, proceed as follows:

- Open the tailgate;
- Remove the light unit (**A-fig. 47**) levering in the point shown by the arrow;

– Replace the bulb (**B-fig. 48**) releasing it from the side contacts, making sure that the new bulb is correctly clamped between the contacts;

– Refit the light unit inserting it in its correct position firstly on one end and then on the other until it clicks into place (**C**).

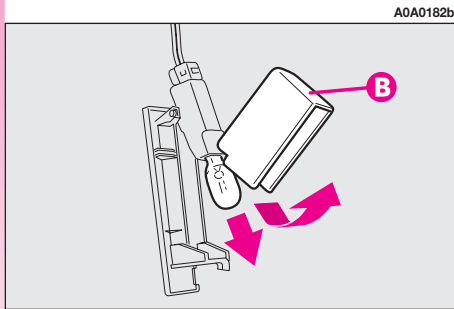

fig. 46

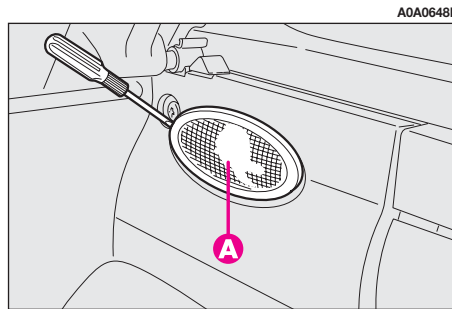

fig. 47

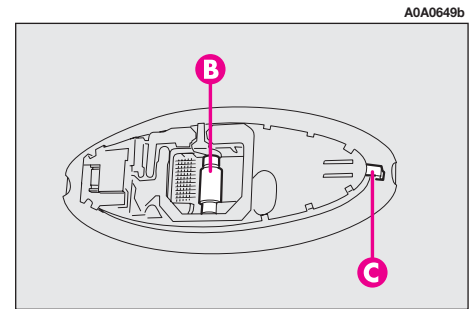

fig. 48

IN THE EVENT OF A BLOWN FUSE

GENERAL

The fuse is a protective device for the electric system: it comes into action (i.e. it cuts off) mainly due to a fault or improper action on the system.

When a device does not work, check the efficiency of its fuse. The conductor element (**A**-fig. 49) must be intact; if not, replace the fuse with one of the same amp rating (same colour).

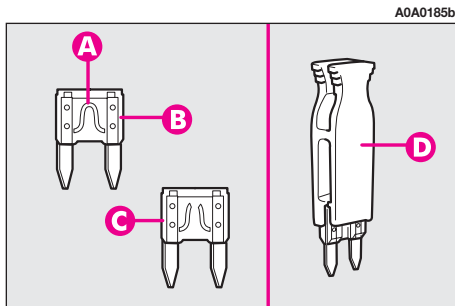

fig. 49

(B) - Undamaged fuse

(C) - Fuse with damaged filament.

Remove the blown fuse using the pincer provided (D), in the control box.



Never replace a fuse with metal wires or anything else. Always use an intact fuse of the same colour.



Never replace a fuse with another with a higher amp rating; DANGER OF FIRE.



If a general fuse (MAXI-FUSE or MEGA-FUSE) cuts in, do not attempt any repair and contact Alfa Romeo Authorised Services.



Before replacing a fuse, make sure the ignition key has been removed and that all the other services are switched off and/or disengaged.



If a fuse blows again, contact an Alfa Romeo Authorised Service.

Alfa GT fuses are located in three fuse boxes set on the dashboard, on battery positive terminal and near the battery.

To gain access to the fuses in the fuse box on the dashboard, loosen the two retainers (A-fig. 50) and remove the protective cover (B).

To gain access to the fuses in the fusebox on the battery post, remove the protective cover pressing the opening catches (front).

Access is gained to the control box next to the battery releasing the perimetral catches (A-fig. 51) and removing the protective cover (B).

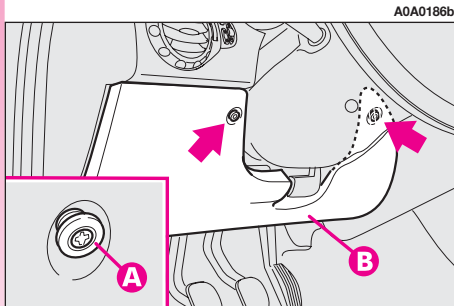

fig. 50

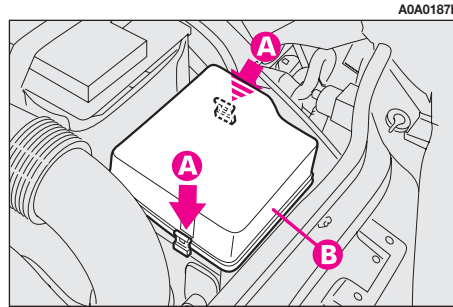

fig. 51

To locate the protection fuses, consulting the summary table on the following pages, refer to the following illustrations **fig. 52**, **fig. 53** and **54**.

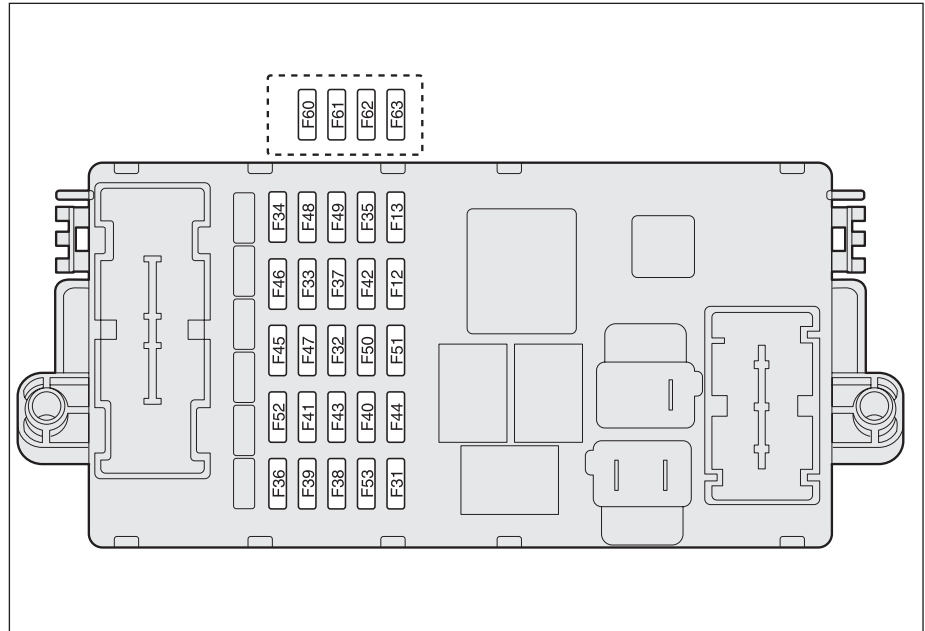

fig. 52 - Fuse box on the dashboard

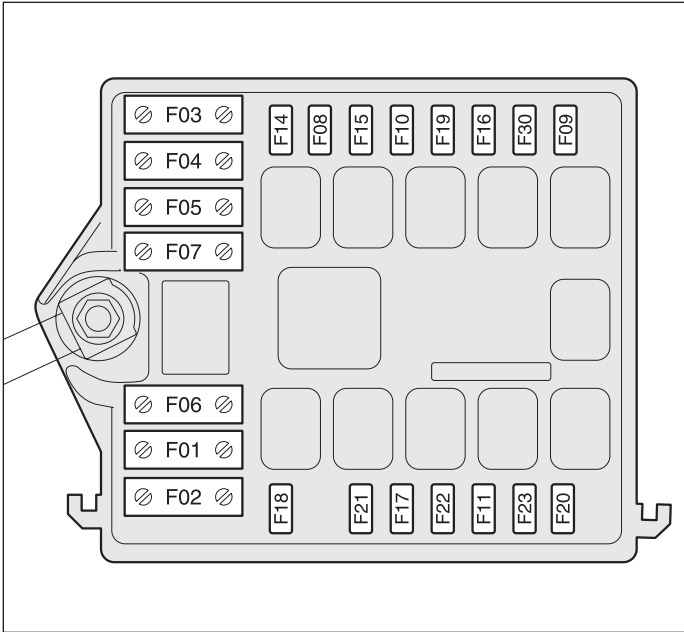

fig. 53 - Fuse box near the battery

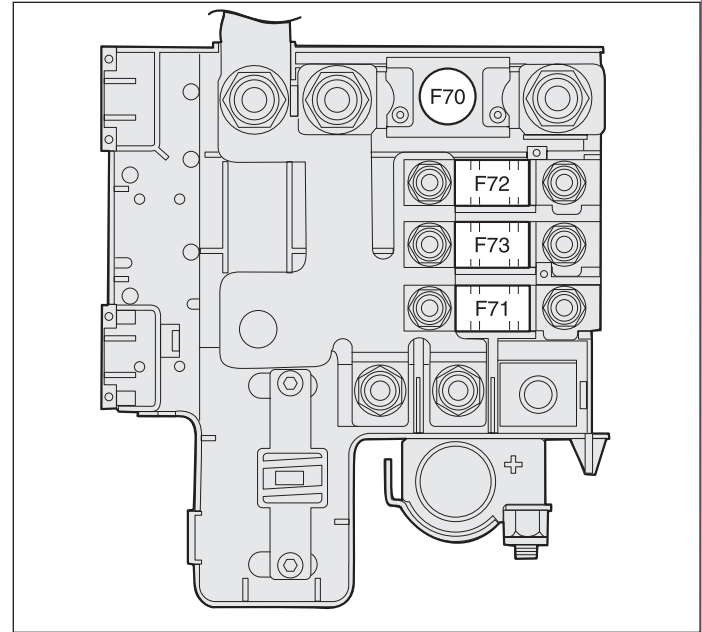

fig. 54 - Fuse box on battery positive terminal

FUSE SUMMARY TABLE

LIGHTS	FIGURE	FUSE	AMPERES
Hazard warning lights	52	F53	10
Right dipped-beam headlight	52	F12	10
Left dipped-beam headlight	52	F13	10
Right main-beam headlight	53	F14	10
Left main-beam headlight	53	F15	10
Foglights	53	F30	15
Braking light	52	F37	10
Reversing light	52	F35	7.5
+30 direction indicators	52	F53	10

SERVICES	FIGURE	FUSE	AMPERES
Selespeed transmission pump	53	F03 (MAXI-FUSE)	30
Additional heater	54	F73 (MAXI-FUSE)	30
Headlight aiming device	52	F13	10
Climate control system	52	F31	7.5
Climate control system	52	F39	15
Climate control compressor	53	F19	7.5
Heater unit relay coils	52	F31	7.5

SERVICES	FIGURE	FUSE	AMPERES
Key-operated +30	52	F32	15
Selespeed transmission	52	F32	15
Selespeed transmission	52	F51	7.5
Radio	52	F39	15
Navigator	52	F39	15
Rearscreen heating	52	F40	30
Windscreen - rearscreen washer (pump)	52	F43	30
Cigar lighter	52	F44	20
Seats with electric heating	52	F45	15
Heated wing mirrors – heated nozzles	52	F41	7.5
Cruise control	52	F35	7.5
Central door locking	52	F38	20
Headlight washer	53	F09	20
Services + 30	52	F39	15
Primary services (electronic injection)	53	F17	7.5
Secondary services (electronic injection)	53	F11	15
Secondary services	52	F49	7.5

SERVICES	FIGURE	FUSE	AMPERES
Volumetric sensors	52	F39	15
ESP system sensor	52	F42	7.5
Steering angle sensor	52	F42	7.5
EOBD system diagnosis socket	52	F39	15
Cell phone provision	52	F39	15
Driver's door control unit supply	52	F47	20
Passenger's door control unit supply	52	F48	20
Control lighting	52	F49	7.5
Climate control system control lighting	52	F35	7.5
Instrument cluster	52	F37	10
Instrument cluster	52	F53	10
Driver's door control unit	52	F39	15
ABS control unit	52	F42	7.5
ABS control unit	53	F04 (MAXI-FUSE)	50
Dashboard control unit	53	F02 (MAXI-FUSE)	50
Air - bag control unit	52	F50	7.5
Electronic injection control unit +30	53	F18	7.5
Engine compartment control box (petrol versions)	54	F70 (MEGA-FUSE)	125
Dashboard control unit	54	F71 (MAXI-FUSE)	70
Trailer control unit	52	F36	10

SERVICES	FIGURE	FUSE	AMPERES
Climate control fan	53	F05 (MAXI-FUSE)	40
Radiator fan (first speed - petrol versions)	53	F06 (MAXI-FUSE)	30
Radiator fan (second speed - petrol versions)	53	F07 (MAXI-FUSE)	50
Horn	53	F10	15
Fuel pump	53	F21	15
Injectors (petrol versions)	53	F22	15
Ignition coils	53	F21	15
Tailgate electric unlocking	52	F60 (*)	25
Electronic injection system	53	F16	7.5
Bose system	52	F61 (*)	15
Bose system	52	F62 (*)	15
Additional heater	53	F08	30
Ignition switch	54	F72 (MAXI-FUSE)	30
Glow plug warming (JTD versions)	53	F01 (MAXI-FUSE)	50
Heated fuel oil filter (JTD versions)	53	F20	20
Engine compartment control box (JTD versions)	54	F70 (MEGA-FUSE)	150
Radiator fan (first speed — JTD versions)	53	F06 (MAXI-FUSE)	40
Radiator fan (second speed — JTD versions)	53	F07 (MAXI-FUSE)	60
Injectors (JTD versions)	53	F22	20

(*) Fuse behind dashboard control box on an auxiliary bracket.

IN THE EVENT OF A FLAT BATTERY

Before anything else, you are advised to read the precautions for preventing the battery from draining and for ensuring long life in the “car maintenance” chapter.

CHARGING THE BATTERY

IMPORTANT The battery charging procedure is described only for information purposes. This operation should be carried out by Alfa Romeo Authorised Services.

Charging should be slow at a low amp rating for 24 hours. Charging for a longer time may damage the battery.

Charge the battery as follows:

- Disconnect the battery negative terminal (–).
- Connect the charger cables to the battery terminal ensuring that the bias is correct.
- Turn on the charger.
- After charging, turn off the charger before disconnecting it from the battery.
- Re-connect the battery negative terminal (–).



The liquid contained in the battery is poisonous and corrosive. Avoid contact with the skin or eyes. The battery should be charged in a well ventilated place, away from naked flames or possible sources of sparks: danger of explosion and fire.



Do not attempt to charge a frozen battery: it must firstly be thawed, otherwise it may burst. If freezing has occurred, the battery should be checked by skilled personnel to make sure that the internal elements are not damaged and that the body is not cracked, with the risk of leaking poisonous and corrosive acid.

IF THE CAR IS TO BE TOWED

The tow ring supplied with the car is housed in the tool box under the boot mat.

To install the tow ring, proceed as follows:

- Take the tow ring from the tool box.
- Remove the cover (A) snap-fitted on the front (fig. 55) or rear (fig. 56) bumper. To do this, using the flat-bladed screwdriver provided, protect the tip with a soft cloth to avoid damaging the car.

- Firmly screw the ring in its housing.



Before tightening the ring carefully clean the threaded housing. Before beginning to tow the car, make sure that the ring is firmly tightened in its threaded housing.



Before starting to tow, turn the ignition key to MAR and back to STOP, again without removing it. Removing the key automatically engages the steering lock resulting in the impossibility to steer the wheels. When towing remember that without the help of the engine brake and power steering greater effort is required on the pedal and steering wheel. Do not use flexible cables for towing and avoid jerks. During towing operations make sure that fastening the joint to the car does not damage the components in contact with it. When towing the car, it is compulsory to follow specific traffic regulations concerning both the towing device and behaviour on the road.

A0A0650b

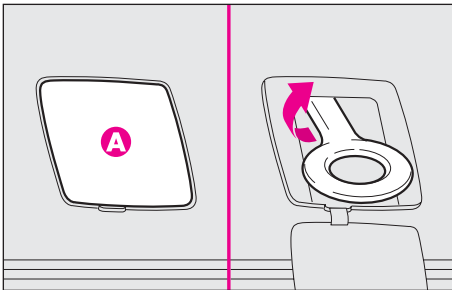

fig. 55 - front

A0A0670b

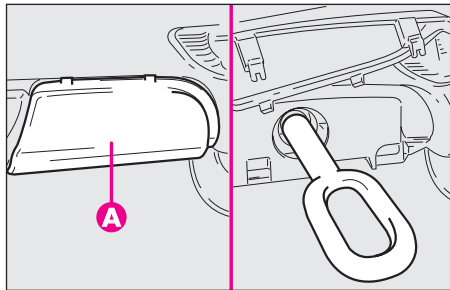

fig. 56 - rear



Do not start the engine when towing the car.

IMPORTANT For versions with Sele-speed transmission, make sure that the gears are in neutral (**N**) (checking that the car moves if pushed) and then proceed as for towing a normal car with mechanical transmission, following the instructions given previously.

Should it be impossible to set the gears to neutral, do not tow the car and contact Alfa Romeo Authorised Services.

IF THE CAR IS TO BE LIFTED



The car may fall if the jack is not positioned correctly. Never use the jack for higher capacities than the one stated on the label.

These points are identified by symbol ▼ on the bottom of the sidemember.



Take care when positioning the arms of the lift or workshop lift to avoid damaging the side strips.

USING AN ARM LIFT OR WORKSHOP LIFT

The car must only be lifted laterally positioning the ends of the arms or the workshop lift in the areas illustrated, approx. 40 cm from the profile of the wheelhouse (**fig. 57**).

A0A0672b

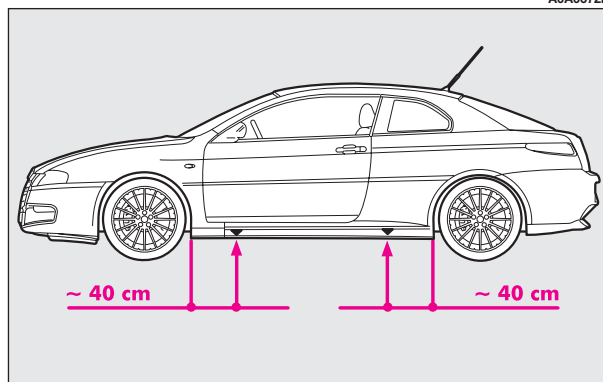

fig. 57

IN THE EVENT OF AN ACCIDENT

- It is important to keep calm.
- If you are not directly involved, stop at least a few dozen metres away from the accident.
- On motorways, stop without blocking the emergency lane.
- Turn the engine off and the hazard warning lights on.
- At night, illuminate the place of the accident with the headlights.
- Take care, do not risk being run over.
- Signal the accident placing the triangle at regulation distance in a clearly visible place.
- Call the emergency organisation, giving the most accurate information possible. On motorways use the special phones provided.

– In motorways pileups, especially with poor visibility, the risk of being involved in other crashes is high. Leave the car immediately and go beyond the guard-rail.

– If doors are blocked, do not try to get out of the car breaking the windscreen which is stratified. The windows and rear screen are easier to break.

– Remove the ignition key of the cars involved.

– If you note a smell of fuel or other chemical products, do not smoke and have a cigarette stubbed out.

– To put out fires, even small ones, use the extinguisher, blankets, sand, or earth.

Never use water.

– If use of the lighting system is not necessary, disconnect the battery negative terminal (–).

IF PEOPLE ARE INJURED

– An injured person must never be abandoned. Helping is compulsory also for persons not directly involved in the accident.

– Do not crowd around injured people.

– Reassure the injured person that help is on the way, and stay near to overcome any panic.

– Release or cut the seat belt restraining injured persons.

– Do not give injured persons anything to drink.

– An injured person should never be moved except in the following circumstances.

– Remove an injured person from the car only in danger of fire, sinking or falling. When removing an injured person: do not pull the limbs or bend the head and keep the body as horizontal as possible.

FIRST AID KIT

In addition to the first-aid kit, it is also wise to keep an extinguisher and a blanket in the car.

CAR MAINTENANCE

SCHEDULED SERVICING

Correct maintenance is determined in ensuring long car life under the best conditions.

This is why Alfa Romeo has programmed a series of checks and maintenance operations every 20,000 km.

IMPORTANT On versions fitted with reconfigurable multifunction display, at 2000 km from the maintenance deadline, the display will show "REFER TO SERVICE MANUAL" which is shown again turning the ignition key to **MAR**, every 200 km. For further details, see "Service" in the "Reconfigurable multifunction display".

It is however wise to remember that Programmed Maintenance does not completely cover all the car's requirements: also in the initial period before the 20,000 km service coupon and later, between one coupon and another, ordinary care is still necessary such as for example routinely checking and topping up the level of fluids, checking the tyre pressure, etc...

IMPORTANT The Programmed Maintenance coupons are specified by the Manufacturer. The failure to have them carried out may invalidate the warranty.

The Programmed Maintenance service is carried out by all Alfa Romeo Authorised Services, at pre-established times.

If during each operation, in addition to the ones programmed, the need arises for further replacements or repairs, these may be carried out only with the explicit agreement of the customer.

IMPORTANT You are advised to contact Alfa Romeo Authorised Services in the event of any minor operating faults, without waiting for the next service coupon.

SCHEDULED MAINTENANCE PROGRAMME

Thousands of km	20	40	60	80	100	120	140	160	180
Check tyre conditions/wear and adjust pressure if necessary	●	●	●	●	●	●	●	●	●
Check operation of lighting system (headlights, direction indicators, hazard warning lights, boot, passenger compartment, glovebox lights, warning lights, etc..)	●	●	●	●	●	●	●	●	●
Check operation of windscreen washer system, adjust spray jets	●	●	●	●	●	●	●	●	●
Check position/wear of windscreen/rearscreen wiper blades	●	●	●	●	●	●	●	●	●
Check operation of front disk brake pad wear indicator	●	●	●	●	●	●	●	●	●
Check wear conditions of rear disk brake pads		●		●		●		●	
Sight check the conditions of: body exterior, underbody protection, stiff pipes and hoses (exhaust - fuel supply - brakes), rubber parts (boots - sleeves - bushes etc..)	●	●	●	●	●	●	●	●	●
Check cleanness of locks, bonnet and boot and lever cleanness, and lubrication	●	●	●	●	●	●	●	●	●
Sight inspect accessory drive belt conditions			●						●
Check handbrake lever stroke adjustment		●		●		●		●	
Change air cleaner cartridge (petrol versions)		●		●		●		●	
Change air cleaner cartridge (JTD versions)	●	●	●	●	●	●	●	●	●
Top up fluid levels (engine coolant, brakes, windscreen washer, battery, etc..)	●	●	●	●	●	●	●	●	●

	Thousands of km	20	40	60	80	100	120	140	160	180
Check and if necessary top up the Selespeed automatic transmission oil level (2.0 JTS versions)		●	●	●	●	●	●	●	●	●
Sight check for conditions of timing gear drive toothed belt (3.2 V6 and JTD versions)				●						●
Check emissions/smoke at the exhaust (JTD versions)			●		●		●		●	
Check operation of engine control system (through diagnosis socket)			●		●		●		●	
Check mechanical transmission oil level					●				●	
Change counter-rotating shaft drive belt							●			
Change timing gear drive belt (1.8 T.SPARK and 2.0 JTS versions) (*)				●			●			●
Change timing gear drive belt (3.2 V6 and JTD versions) (*)							●			
Change accessory poly-V drive belt							●			
Change spark plugs (petrol versions)						●				
Change engine oil and oil filter (petrol versions) (or every 24 months) 		●	●	●	●	●	●	●	●	●
Change engine oil and oil filter (diesel with DPF versions) (**) (or every 24 months)										
Change engine oil and oil filter (diesel without DPF versions) (**) (or every 24 months)		●	●	●	●	●	●	●	●	●
Change brake fluid (or every 24 months)				●			●			●
Change fuel filter (JTD versions)		●	●	●	●	●	●	●	●	●
Change pollen filter (or every year)		●	●	●	●	●	●	●	●	●

(*) Regardless of the km covered, the timing belt shall be replaced every 4 years for particularly demanding use (cold climates, driving in the city, idling for a long time) or in any case every 5 years.

(**) Engine oil and oil filter shall actually be changed according to the conditions of use of the car and it is indicated by the relevant warning light or message (where provided) on the instrument panel (see "Warning lights and messages" paragraph).

 If the car is used mainly on urban routes or if the yearly kilometres travelled are less than 10,000 km, the engine oil and filter must be changed every 12 months.

ANNUAL INSPECTION PROGRAMME

For cars with an annual mileage of below 20,000 km (for example about 10,000 km) the following yearly inspection programme is advised:

- Check tyre conditions/wear and if necessary adjust the pressure (including spare wheel)
- Check operation of lighting system (headlights, direction indicators, hazard warning lights, boot, passenger compartment, glovebox lights, warning lights, etc.)
- Check operation of windscreen wiper system, spray jet adjustment
- Check windscreen blade position/wear
- Check front disk brake pad conditions and wear
- Check cleanness of bonnet and boot locks, and lever cleanness and lubrication.

- Sight check for conditions of: engine, gearbox, transmission, pipes (exhaust - fuel supply - brakes), rubber parts (boots - sleeves - bushes etc..), brake and fuel supply system hoses

- Check battery charge
- Sight check for conditions of various drive belts
- Check and if necessary top up fluid levels (engine coolant, brakes, windscreen washer, battery etc.)
- Change engine oil and oil filter
- Change pollen filter.

ADDITIONAL OPERATIONS

Every **1000 km** or before long journeys, check and if necessary top up:

- engine coolant fluid level
- brake/hydraulic clutch control fluid level
- power steering fluid level
- windscreen washer and headlamp washer fluid level
- tyre pressure and conditions.

Every **3000 km** check and if necessary top up the engine oil level.

The use of **FL Selenia** products is recommended which have been designed and made expressly for Alfa Romeo cars (see “Refuelling” in the “Technical Specifications” chapter).

IMPORTANT **Engine oil**

Should prevailing use of the car be under one of the following specially heavy conditions:

- trailer or caravan towing
- dusty roads
- short distances (less than 7-8 km) repeated and with external temperatures below zero
- frequently idling engines or long distance low speed driving or in case of a long term inactivity

replace engine oil more frequently than required on the Scheduled Maintenance Programme.

IMPORTANT **Diesel filter**

The variety of the degree of purity of the fuel oil in commerce may make it necessary to change the fuel oil filter more frequently than stated in the Scheduled Maintenance Programme. If the engine is “sobbing” it is a sign that the filter needs changing.

IMPORTANT **Air cleaner**

Using the car on dusty roads change the air cleaner more frequently than specified in the Schedule Maintenance Programme.

For any doubts concerning the intervals between the engine oil and air cleaner replacement in relation to how the car is used, contact Alfa Romeo Authorised Services.

IMPORTANT Battery

It is advisable to check the battery charge, preferably at the onset of winter, to prevent the possibility of the electrolyte freezing.

This check should be carried out more frequently if the car is used mainly for short trips, or if it is fitted with accessories that permanently absorb electricity even with the ignition key removed, especially in the case of after market accessories.

If the car is used in hot climates or particularly harsh conditions it is wise to check the level of the battery fluid (electrolyte) more frequently than specified in the Scheduled Maintenance Programme.

IMPORTANT Pollen filter

If the car is used frequently in dusty or heavily polluted environments it is advisable to replace the filtering element more frequently; in particular it should be replaced if a reduction of the amount of air admitted to the passenger compartment is noted.



Car maintenance should be entrusted to Alfa Romeo Authorised Services. For routine and minor maintenance operations you wish to carry out yourself, always make sure you have the proper equipment, genuine Alfa Romeo spares and the necessary fluids; do not however carry out these operations if you have no experience.

CHECKING LEVELS



Never smoke while working in the engine compartment; gas and inflammable vapours may be present, with the risk of fire.



When topping up take care not to confuse the various types of fluids: they are incompatible with one another and could seriously damage the car.

1 Engine oil - 2 Battery - 3 Brake fluid - 4 Windscreen/rear window/headlight washer fluid - 5 Engine coolant - 6 Power steering fluid - 7 Selespeed transmission oil (2.0 JTS Selespeed versions)

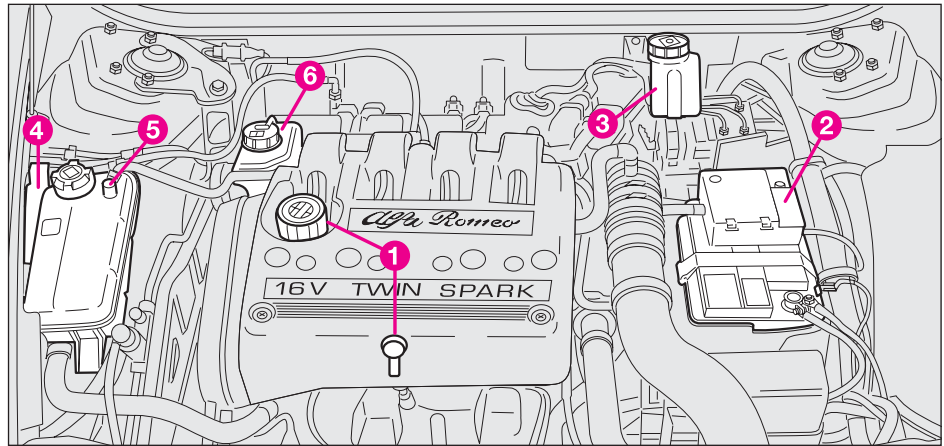

fig. 1 - 1.8 T. SPARK version

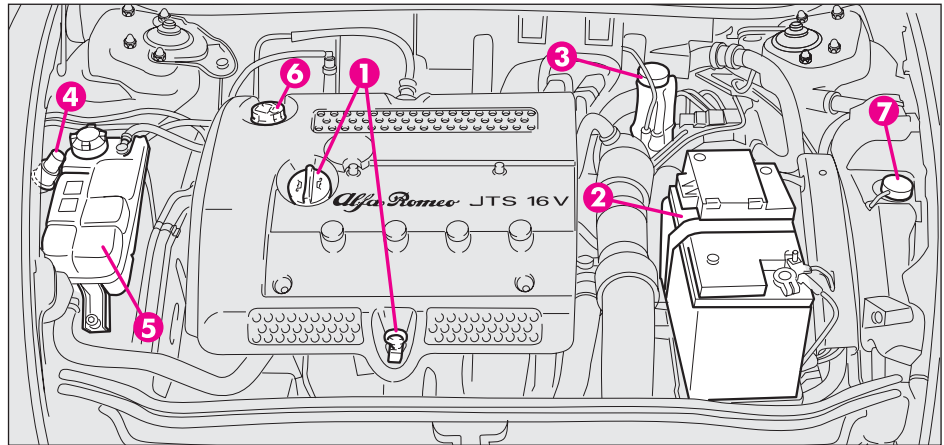

fig. 2 - 2.0 JTS version

A0A0736b

A0A0681b

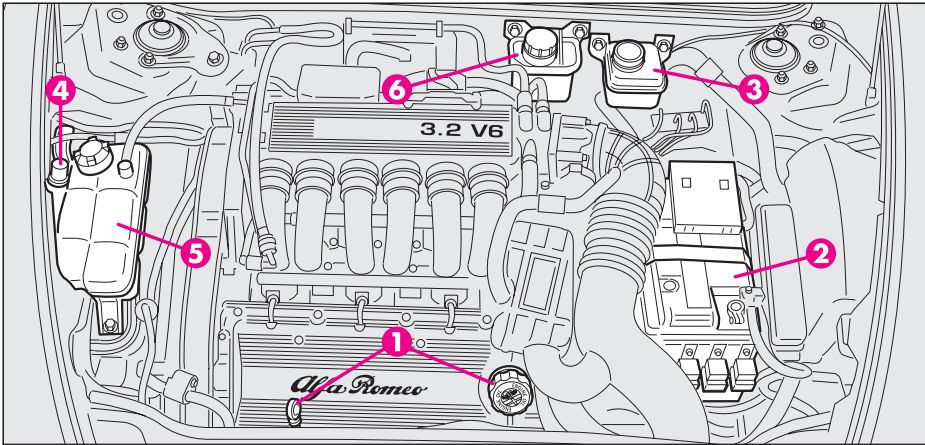

fig. 3 - 3.2 V6 version

1 Engine oil - **2** Battery - **3** Brake fluid - **4** Windscreen/rear window/headlight washer fluid - **5** Engine coolant - **6** Power steering fluid

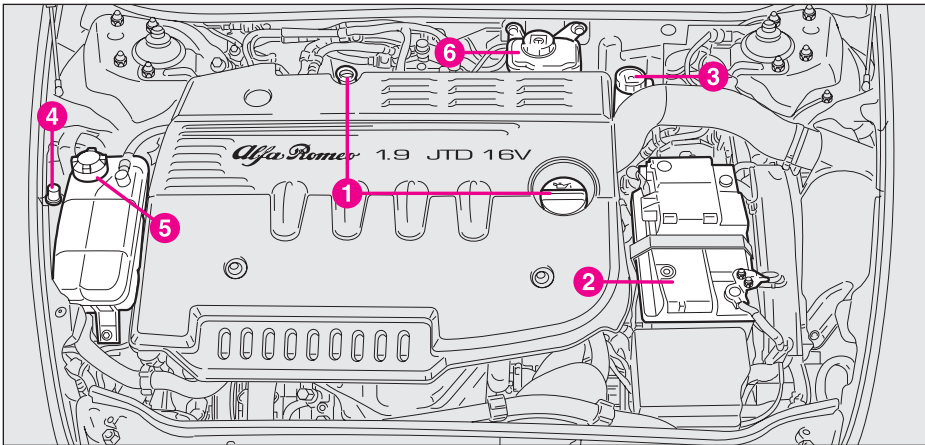

fig. 4 - JTD 16V version

1 Engine oil - **2** Battery - **3** Brake fluid - **4** Windscreen/rearscreen/headlamp washer fluid - **5** Engine coolant fluid - **6** Power steering fluid

ENGINE OIL (fig. 5-6-7-8)

The engine oil should be checked with the car on a level surface a few minutes (about 5) after the engine has been switched off.

Remove the dipstick (A), clean it, put it back in completely, remove it and check that the level is within the **MIN** and **MAX** marks on the dipstick. The interval between the **MIN** and **MAX** marks correspond to about one litre of oil.



Never add oil with characteristics (classification, viscosity) which are different from those of the oil already in the circuit.



When the engine is hot, take care when working inside the engine compartment to avoid burns. Remember that when the engine is hot, the fan may cut in: danger of injury.

If the oil level is near or even below the **MIN** mark, add oil through the filter neck (B), until reaching the **MAX** mark.

IMPORTANT If a routine check reveals that the level is above the **MAX** mark, contact Alfa Romeo Authorised Services to have the correct level restored.

IMPORTANT After topping up the oil, before checking the level again, run the engine a few seconds and wait for a few minutes after stopping it.

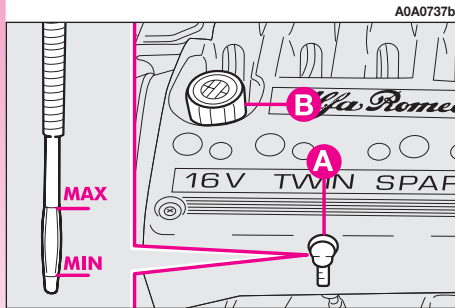

fig. 5 - 1.8 T. SPARK version

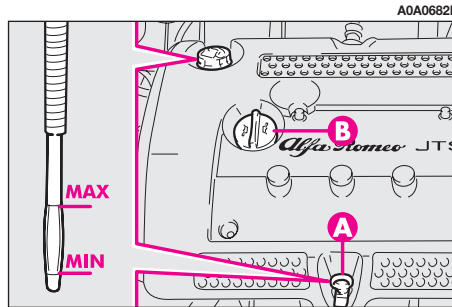

fig. 6 - 2.0 JTS version

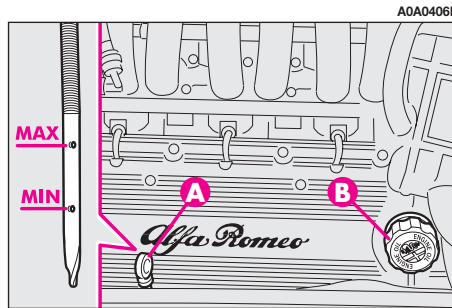

fig. 7 - 3.2 V6 version

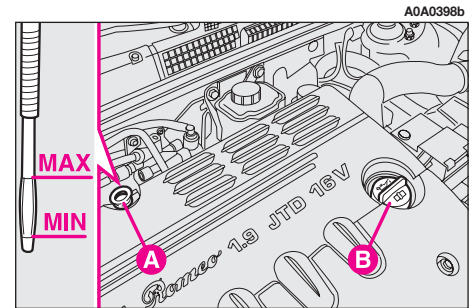

fig. 8 - JTD 16V version

Engine oil consumption

Max engine oil consumption is usually 400 grams every 1000 km.

During the initial period of use the engine settles, therefore engine oil consumption may be considered stabilised only after the first 5000 ÷ 6000 km.

IMPORTANT Engine oil consumption depends on the way of driving and the conditions of use of the car.



Used engine oil and filter contain harmful substances for the environment. Contact Alfa Romeo Authorised Services to have the oil and the filter changed, as they are equipped to dispose of the waste oil and filters respecting nature and the law.

SELESPEED TRANSMISSION OIL (fig. 9)

The Selespeed transmission oil should be checked with the car on a level surface and with the engine stopped and cold.

To check the level, proceed as follows:

- turn the ignition key to **MAR**;
- disconnect the breather tube and remove the cap (**A**) checking that the level corresponds with the **MAX** mark on the dipstick integrated with the cap;
- if the oil is below the **MAX** mark, top up to reach the correct level;

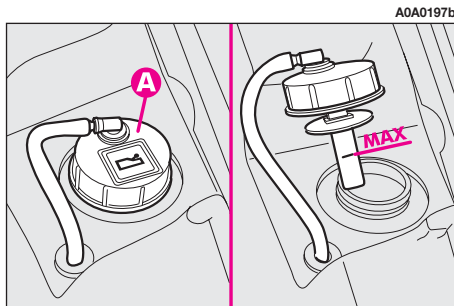

fig. 9

– after refitting the cap, insert the breather tube firmly on the housing on the cap and turn the ignition key to **STOP**.



Do not add oil with specifications other than that already in the gearbox.



Used gearbox oil contains dangerous substances for the environment. For changing the oil we advise contacting Alfa Romeo Authorised Services who are equipped for disposing of used oil respecting nature and the law.



Be very careful working inside the engine compartment if the engine is hot: danger of burns. Remember that the fan may cut in if the engine is very hot: danger of injury.

ENGINE COOLANT FLUID

(fig. 10)



Do not remove the cap when the engine is hot: danger of burns.

The level of the coolant in the header tank (reservoir) should be checked with the engine cold and the car on a level surface and it should be between the **MIN** and **MAX** marks on the tank.

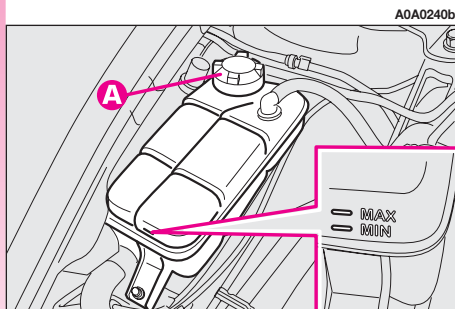

A0A0240b

If the level is low, loosen the header tank cap (**A**) and slowly pour a mixture of 50% distilled water and 50% **PARAFLU UP FL Selenia** through the filler neck until nearing the **MAX** mark.

The antifreeze mixture of 50% **PARAFLU UP** and 50% distilled water guarantees protection down to -35°C .



The cooling system uses PARAFLU UP antifreeze. Do not add fluid having different specifications from that already existing. PARAFLU UP cannot be mixed with other types of fluids. Should other fluids be added, do not start the engine and contact Alfa Romeo Authorized Services as soon as possible.



The cooling system is pressurised. If necessary, replace the cap only with another genuine one, otherwise system efficiency could be compromised. Do not remove the reservoir cap when the engine is hot: you risk scalding yourself.

POWER STEERING FLUID**(fig. 11)**

Check that the level of the oil in the reservoir is at maximum.

This operation should be carried out with the car on a level surface and the engine switched off and cold.

Check that the level reaches the **MAX** mark on the reservoir or coincides with the upper notch (maximum level) on the dipstick (**A**) integral with the reservoir cap.

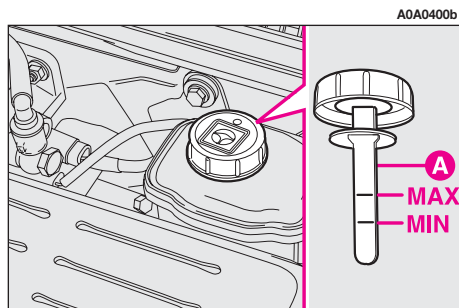

fig. 11

If the oil level in the reservoir is below the specified one, top up only with one of the products listed in the “Fluids and lubricants” table in the “Technical specifications” chapter proceeding as follows:

- Start the engine and wait for the oil level in the reservoir to stabilise.
- With the engine running, turn the steering wheel lock to lock a few times.
- Top up to the **MAX** level notch, then refit the cap.



Do not allow the power steering fluid to touch hot parts of the engine: it is inflammable.



Oil consumption is very low; if topping up again is needed shortly afterwards, have the system checked for possible leaks by Alfa Romeo Authorised Services.

BRAKE AND HYDRAULIC CLUTCH FLUID (fig. 12)

Check that the fluid level in the reservoir is at maximum. Top up with the brake fluid specified in the table “Fluids and lubricants” (see section “Technical specifications”).

NOTE Clean accurately the tank cap **A** and the surrounding surface. When opening the cap take the utmost care to prevent impurities entering the tank. When topping up, always use a funnel with built-in filter with mesh equal to or lower than 0.12 mm.

IMPORTANT For this operation it is however recommended to contact Alfa Romeo Authorised Services.

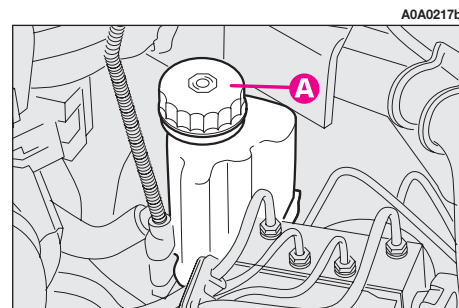

fig. 12



Make sure that the highly corrosive brake fluid does not drip onto the paintwork. If it does, wash it off immediately with water.



Brake and clutch fluid is poisonous and highly corrosive. In the event of accidental contact, wash the parts concerned immediately with neutral soap and water, then rinse thoroughly. See a doctor at once if the fluid is swallowed.



The © symbol on the container indicates synthetic brake fluid, distinguishing it from the mineral kind. Using mineral fluids irreversibly damages the special braking system rubber seals.

IMPORTANT Brake and hydraulic clutch fluid is hygroscopic (i.e. it absorbs moisture). For this reason, if the car is mainly used in areas with a high degree of atmospheric humidity, the fluid should be replaced at more frequent intervals than specified in the Scheduled Maintenance Programme.

WINDSCREEN/REARSCREEN HEADLIGHT WASHER FLUID (fig. 13)

Open the cap (A) and check the level in the reservoir.

If necessary top up using a mixture of water and **TUTELA PROFESSIONAL SC 35** fluid as follows:

– 30% of **TUTELA PROFESSIONAL SC 35** and 70% water in summer;

– 50% of **TUTELA PROFESSIONAL SC 35** and 50% water in winter;

– in the case of temperatures below -20°C use **TUTELA PROFESSIONAL SC 35** fluid neat.



Some commercial additives for windscreen washers are inflammable. The engine compartment contains hot components which may set it on fire.



Do not travel with the windscreen washer reservoir empty: the action of the windscreen washer is fundamental for improving vision.



To avoid damaging the pump motor, do not use the windscreen/rear screen washers when the reservoir is empty.

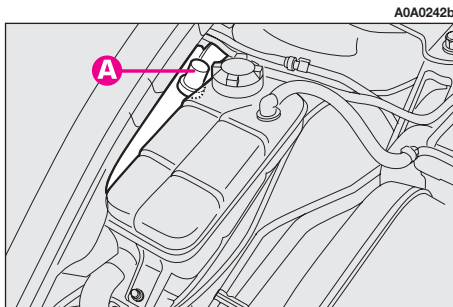

fig. 13

AIR CLEANER

The air cleaner is connected to the temperature and air flow sensors which send to the control unit the electric signals needed for correct operation of the injection and ignition system.

It must therefore always be in perfect conditions, to ensure correct operation of the engine, low consumption and exhaust emission levels.



If the operations concerning cleaner replacement described below are not carried out correctly and with the due precautions, they may compromise the travelling safety of the car. You are recommended to have this operation carried out by Alfa Romeo Authorised Services.



If the car is habitually used in dusty areas, the cleaner should be replaced at shorter intervals than those specified in the Programmed Maintenance Schedule.



Any attempt to clean the cleaner may damage it, leading to serious engine damage.

DIESEL FUEL FILTER (diesel versions)

DRAINING CONDENSATION WATER



The presence of water in the supply circuit may cause serious damage to the entire injection system and cause irregular running of the engine. If the warning message + symbol are shown on the reconfigurable multifunction display contact Alfa Romeo Authorized Services as soon as possible to have the system relieved. If warning indications turn on after refuelling, water has probably been poured into the tank: turn the engine off immediately and contact Alfa Romeo Authorized Services.

POLLEN FILTER

Have the dust/pollen filter checked once a year by Alfa Romeo Authorised Services, preferably at the onset of summer.

If the car is mainly used in dusty or heavily polluted areas, the filter should be changed at more frequent intervals than specified in the Scheduled Maintenance Programme.

IMPORTANT The failure to replace the pollen filter can considerably reduce the effectiveness of the climate control system.

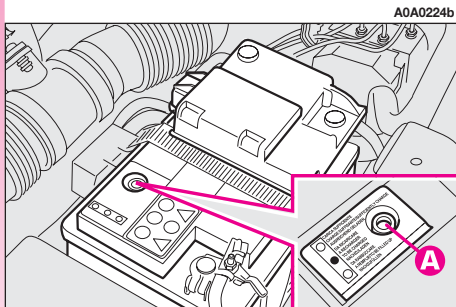

230 fig. 14

BATTERY

The battery is of the “Limited maintenance” type: under normal conditions of use the electrolyte does not need topping up with distilled water.

Contact Alfa Romeo Authorised Services to have the battery checked/replaced.



Incorrect fitting of electrical accessories can seriously damage the car. If after buying the car, you wish to install electric accessories (alarm, sound system, radiotelephone, etc.) contact Alfa Romeo Authorized Services who will be able to suggest the most suitable devices and above all advise about the need to use a more powerful battery.



Batteries contain substances that are very harmful for the environment. You are advised to have the battery changed at Alfa Romeo Authorized Services, which are properly equipped for disposing of used batteries respecting nature and the law.



If the car is to remain stationary for a long time in very cold weather, remove the battery and take it to a warm place, otherwise it might freeze.



When doing any work on the battery or near it, always wear special protective goggles.



The liquid in the battery is poisonous and corrosive. Avoid contact with eyes and skin. Do not bring naked flames or possible sources of sparks near to the battery: risk of fire and explosion.



Working with a low fluid level may damage the battery irreversibly, even causing it to burst.

CHECKING THE CHARGE

The battery charge may be checked through the indicator **A** (where required) set on the battery cover and acting according to the colour the indicator shows.

Should the battery be not fitted with battery charge inspection device (optical electrolyte indicator), inspection operations shall be carried out by skilled personnel only.

Refer to the table below or to the label (fig. 15) on the battery itself.

A0A0393b

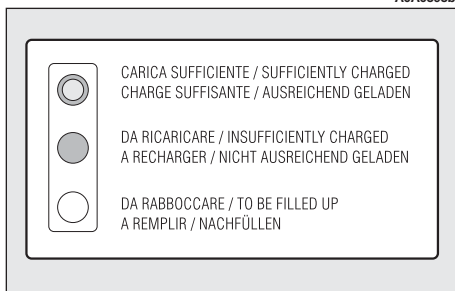

fig. 15

CHARGING THE BATTERY

IMPORTANT The battery charging procedure is described only for information purposes. This operation should be carried out by Alfa Romeo Authorised Services.

Charging should be slow at a low amp rating for 24 hours. Charging for a longer time may damage the battery.

Charge the battery as follows:

- Disconnect the battery negative terminal (–).
- Connect the charger cables to the battery terminal ensuring that the bias is correct.
- Turn on the charger.

– After charging, turn off the charger before disconnecting it from the battery.

– Re-connect the battery negative terminal (–).



Never attempt to charge a frozen battery: it must firstly be thawed, otherwise it may burst. If freezing has occurred, the battery should be checked before charging by specialised personnel, to make sure that the internal elements are not damaged and that the body is not cracked, with the risk of leaking poisonous and corrosive acid.

Brilliant white colour

Top up the electrolyte

Contact Alfa Romeo Authorised Services

Dark colour without green area in the centre

Low charge level

Charge the battery (you are advised to contact Alfa Romeo Authorised Services)

Dark colour with green area in the centre

Sufficient electrolyte level and charge

No action

IMPORTANT If the battery is kept with a charge of below 50% it is damaged by sulphation, its starting capability is reduced and it is also more subject to the possibility of freezing (this may occur already at -10 °C). In the event of a prolonged inactivity, refer to the paragraph “car inactivity”, in the chapter “Correct use of the car”.

CHANGING THE BATTERY

When changing the battery it should be replaced with another original one with the same characteristics. If it is replaced by a battery with different characteristics, the maintenance intervals given in the Scheduled Maintenance Programme in this chapter are no longer valid and for maintenance it will be necessary to follow the battery Manufacturer’s instructions.

IMPORTANT Lacking power to control units (e.g. battery change/disconnection and replacement of power window control unit protection fuses), window automatism must be reset.

Proceed as follows with **doors closed**:

1. open completely the driver’s window **keeping the button pressed** for at least 3 seconds after full opening;
2. close completely the driver’s window **keeping the button pressed** for at least 3 seconds after full closing;
3. proceed as described in points 1 and 2 also for the passenger’s side;
4. check for proper initialisation by operating the windows in automatic.

USEFUL HINTS TO EXTEND THE LIFE OF YOUR BATTERY

To avoid rapidly draining the battery and ensure that it continues to work correctly, the following should be noted:

- The terminals must always be firmly tightened.
- As far as possible, avoid keeping services on for a long time with the engine stopped (radio, hazard lights, parking lights, etc.).

– When leaving the car parked in a garage, make sure that the doors, bonnet, boot and interior lids are properly shut to prevent lights from staying on.

– Before carrying out any work on the electric system, disconnect the negative cable from the battery.

– If after buying the car, you wish to install electric accessories which require a permanent electric supply (alarm, voice feature, radionavigator with satellite antitheft function etc.) or accessories that burden the electric system, contact Alfa Romeo Authorised Services whose qualified personnel, in addition to suggesting the most suitable devices belonging to Lineaccessori Alfa Romeo, will evaluate the overall electric absorption, checking whether the car’s electric system is capable of withstanding the load required, or whether it should be integrated with a more powerful battery. In fact, as some of these devices continue absorbing energy even when the ignition key is off (car stationary, engine off), they gradually drain the battery.

The maximum absorption of all the accessories (standard and fitted afterwards) should be 0,6 mA x Ah (of the battery), as shown in the following table:

Battery	Maximum permissible loadless absorption
60 Ah	36 mA
70 Ah	42 mA

You are also reminded that services with high current absorption switched on by the user, such as for example: baby bottle warmers, vacuum cleaner, mobile phone, mini fridge, etc., **quicken the battery draining process** if they are turned on with the engine off or running at idle speed.

IMPORTANT When installing additional systems on the car, bear in mind that improper branches on connections of the car wiring are dangerous, particularly if safety devices are involved.

WHEELS AND TYRES

TYRE PRESSURE

Check the tyre pressure of every wheel, including the spare, every two weeks and before a long journey. The pressure should be checked with the tyre rested and cold.

It is normal for the pressure to increase when the car is in use; for the correct tyre inflation pressure, see “Wheels” in the “Technical Specifications” chapter.

Incorrect pressure causes abnormal tyre wear:

- (A): normal pressure: tread evenly worn.
- (B): low pressure: tread particularly worn at the edges.
- (C): high pressure: tread particularly worn in the centre.

Tyres should be changed when the tread thickness is reduced to 1.6 mm.

In any case follow local regulations.

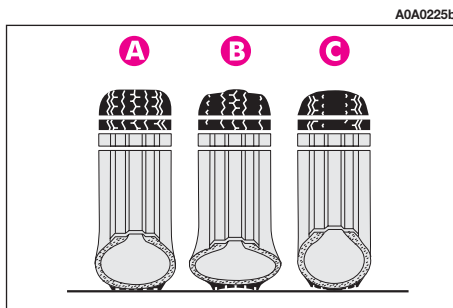

fig. 16

IMPORTANT NOTES

— Where possible, avoid sudden braking, tyre squealing starts, violent bumps against kerbs, potholes or obstacles of various kinds. Prolonged driving on rough roads may damage the tyres;

— Routinely check the tyres for cuts on the sides, swellings or uneven tread wear. If necessary contact Alfa Romeo Authorised Services;

— Avoid overloading the car when travelling: this may cause serious damage to the wheels and tyres;

— If a tyre is punctured, stop immediately and change it to avoid damage to the tyre itself, the rim, suspensions and steering system;

— Tyres age even if they are not used much. Cracks in the tread rubber are a sign of aging. In any case, if the tyres have been on the car for over 6 years, they should be checked by specialised personnel, to see if they can still be used. Also remember to check the compact spare wheel;

— In case of replacement, always fit new tyres, avoiding those of dubious origin;



Remember that car road holding also depends on correct tyre inflation pressure.



Excessive low pressure causes overheating of the tyre with the possibility of serious damage to it.



Do not cross switch the tyres, moving them from the right of the car to the left and vice versa.



Alloy rim painting involving temperatures exceeding 150 °C should be avoided since wheel mechanical characteristics could be impaired.

RUBBER HOSES

As far as the brake system and fuel supply rubber hoses are concerned, carefully follow the Scheduled Maintenance Programme. Indeed, ozone, high temperatures and the prolonged lack of fluid in the system may cause hardening and cracking of the hoses, with possible leaks. Careful control is therefore necessary.

WINDSCREEN/REAR SCREEN WIPERS

BLADES

Periodically clean the rubber part using special products; **TUTELA PROFESSIONAL SC 35** is recommended.

If the rubber blades are bent or worn they should be replaced. In any case they should be changed once a year.

A few simple notions can reduce the possibility of damage to the blades:

- If the temperature falls below zero make sure that ice has not frozen the rubber against the glass. If necessary, thaw using an antifreeze product.

- Remove any snow from the glass: in addition to protecting the blades, this prevents effort on the motor and overheating.

- Do not operate the windscreen and rear screen wipers on dry glass.



Driving with worn wiper blades is a serious hazard, because visibility is reduced in bad weather.

Changing the windscreen wiper blade (fig. 17)

How to remove the blade

Proceed as follows:

- raise the windscreen wiper arm (A);
- turn the blade (B) 90° around the pin (C) set at wiper arm end;
- remove the blade from pin (C).

How to refit the blade

Proceed as follows:

- fit pin (C) into the hole set in the middle of the blade (B);
- refit the wiper arm with the blade on the windscreen.

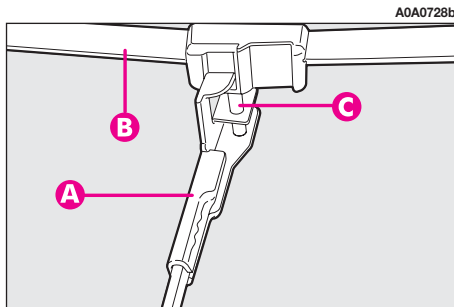

fig. 17

SPRAY NOZZLES (fig. 18)

If the jet of fluid is inadequate, firstly check that there is fluid in the reservoir: see “Checking levels” in this chapter.

Then check that the nozzle holes are not clogged, if necessary use a needle.

If necessary, direct the jet of fluid working on the adjustment screw.

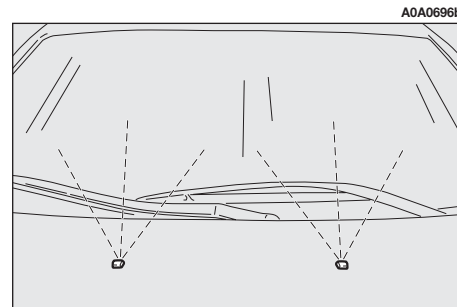

fig. 18

HEADLIGHT WASHERS

(fig. 19)

Regularly check that the spray jets are intact and clean.

If it is necessary to direct the jet, contact an Alfa Romeo Authorized Service.

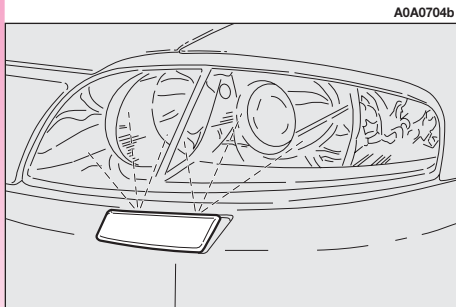

BODYWORK

PROTECTION FROM ATMOSPHERIC AGENTS

The main causes of corrosion are:

- atmospheric pollution
- salty air and humidity (coastal areas, or hot humid climates)
- seasonal environment conditions.

Not to be underestimated is also the abrasive action of wind-borne atmospheric dust and sand and mud and gravel raised by other cars.

On your car, Alfa Romeo has implemented the best manufacturing technologies to effectively protect the bodywork against corrosion.

These include:

- Painting products and systems which give the car particular resistance to corrosion and abrasion.
- Use of galvanised (or pretreated) steel sheets, with high resistance to corrosion.
- Spraying of the underbody, engine compartment, wheel arches and other parts with highly protective wax products.
- Spraying of plastic parts, with a protective function, in the more exposed points: underdoor, inner wheel arch linings, etc.
- Use of “open” boxed sections to prevent condensation and pockets of moisture from triggering rust inside.

CAR EXTERIOR AND UNDERBODY WARRANTY

Your car is covered by warranty against perforation due to rust of any original element of the structure or body. For the general terms of this warranty, refer to Alfa Romeo Warranty booklet.

ADVICE FOR PRESERVING THE BODYWORK

Paint

The paintwork does not only serve an aesthetic purpose but also protects the underlying sheet metal.

In the case of deep scrapes or scores, you are advised to have the necessary touching up carried out immediately to avoid the formation of rust.

Only original products should be used for touching up paint (see "Body paint identification plate" in the "Technical Specifications" chapter).

Normal paint maintenance consists in washing at intervals depending on the conditions and environment of use. For example, in highly polluted areas, or if the roads are sprayed with salt, it is wise to wash the car more frequently.

To correctly wash the car:

- 1) Remove the aerial from the roof to prevent damage to it if the car is washed in an automatic system.
- 2) Spray the car with a low pressure jet of water.
- 3) Pass a sponge moistened with a light detergent solution, rinsing the sponge frequently.
- 4) Rinse well with water and dry with a jet of air or chamois leather.

When drying, take particular care with the less visible parts like door surrounds, bonnet and around the headlights where water may stagnate. The car should not be taken to a closed area immediately, but left in the open so that residual water can evaporate.

Do not wash the car after it has been left in the sun or with the bonnet hot: this may alter the shine of the paintwork.

Exterior plastic parts must be cleaned in the same way as the rest of the car.

Where possible, do not park under trees; the resinous substances many species release give the paint a dull appearance and increase the possibility of triggering the rust processes.

IMPORTANT Bird droppings must be washed off immediately and thoroughly as the acid they contain is particularly aggressive.



Detergents cause water pollution. Therefore the car should be washed in areas equipped for collecting and purifying the liquid used in the washing process.

Windows

Use specific products to clean the windows. Use clean cloths to avoid scratching or altering the transparency of the glass.

IMPORTANT The inside of the rearscreen should be wiped gently with a cloth in the direction of the filaments to avoid damaging the heating device.

Front headlights

IMPORTANT Do not use aromatic substances (e.g. petroleum) or ketones (e.g. acetone) to clean the front headlight plastic transparents.

Engine compartment

At the end of the winter the engine compartment should be carefully washed, without directing the jet against electronic control units. Contact a specialised workshop to have this done.



Detergents cause water pollution. Therefore the engine compartment should be washed in areas equipped for collecting and purifying the liquid used in the washing process.

IMPORTANT The car should be washed with the engine cold and the ignition key at **STOP**. After washing make sure that the various protections (e.g. rubber caps and various covers) have not been damaged or removed.

INTERIOR FITTINGS

Periodically check that water is not trapped under the mats (due to water dripping off shoes, umbrellas, etc.) which could cause oxidation on the sheet metal.



Never use inflammable products like fuel oil ether or rectified petrol for cleaning inside the car. The electrostatic charges generated when rubbing to clean may cause fire.

CLEANING SEATS AND FABRIC AND VELVET PARTS

— Use a soft brush or a vacuum cleaner to remove dust. Velvet is cleaned better if the brush is moistened.

— Rub the seat with a sponge moistened with a solution of water and neutral detergent.

CLEANING LEATHER SEATS

– Remove dried on dirt with a lightly moistened chamois leather or cloth without pressing too hard.

– Remove liquid and grease stains with a dry absorbent cloth without rubbing. Then wipe with a soft cloth or chamois leather with water and neutral soap. If the stain persists, use specific products, carefully following the instructions for use.

IMPORTANT Never use spirit or alcoholbased products, even in small percentage.



Fabric upholstery of your car is purpose-made to withstand common wear resulting from normal use of the car. It is however absolutely necessary to prevent hard and/or prolonged scratching/scraping caused by clothing accessories like metallic buckles, studs, “Velcro” fixings, etc. that stressing locally the fabric could break yarns and damage the upholstery as a consequence.

INTERIOR PLASTIC PARTS

For routine cleaning of interior plastic parts use a soft cloth moistened with water and neutral soap. Remove grease or persisting stains using appropriate solvent-free products designed to preserve appearance and colour of plastic components.

IMPORTANT Never use spirit or petroleum to clean the glass of the instrument panel or other plastic components.



Do not keep aerosol cans in the car. There is the risk they might explode. Aerosol cans must never be exposed to a temperature above 50°C. The temperature inside the car might go well beyond that figure when exposed to the sun’s rays.

STEERING WHEEL/GEAR LEVER KNOB WITH GENUINE LEATHER COVERING

These components shall only be cleaned with water and neutral soap. Never use spirit or alcohol-based products.

Before using special products for cleaning interiors, read carefully label instructions and indications to make sure they are free from spirit and/or alcohol-based substances. If when cleaning the windscreen with special glass products, some drops fall on the leather covering of the steering wheel/gear lever knob remove them immediately and then clean with water and neutral soap.

IMPORTANT Take the utmost care when engaging the steering lock to prevent scratching the leather covering.

TECHNICAL SPECIFICATIONS

IDENTIFICATION DATA

You are advised to note the identification codes. The identification data stamped and given on the labels and their position are the following (**fig. 1**):

- 1 - Identification label
- 2 - Body label
- 3 - Bodywork paint identification label
- 4 - Engine label.

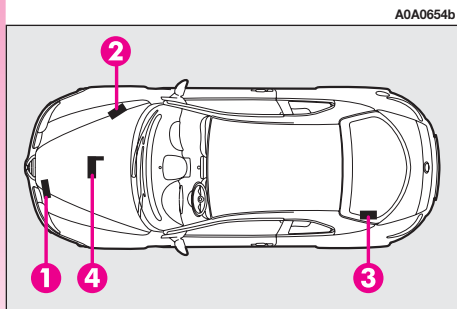

fig. 1

IDENTIFICATION LABEL

This (**fig. 2**) is to be found on the front crossmember of the engine compartment.

It contains the following information:

- (A) Space for details of national homologation
- (B) Space for punching the consecutive chassis number
- (C) Space available for maximum weights authorised by various national regulations
- (D) Space for version and any supplementary indications to those specified

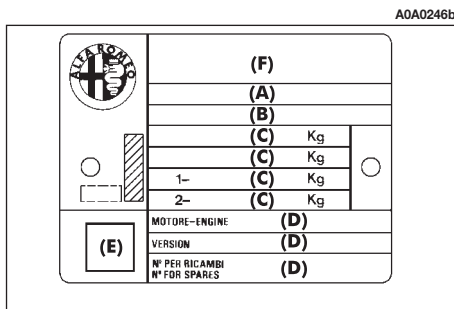

fig. 2

- (E) Space for smoke coefficient (JTD versions)
- (F) Space for punching manufacturer's name.

BODYWORK LABEL

This is located in the engine bay, to one side of the upper right shock absorber (**fig. 3**) and contains:

- Type of vehicle: ZAR 937.000
- Manufacturer's serial number (chassis number).

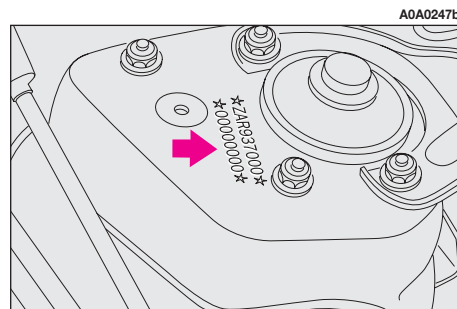

fig. 3

BODYWORK PAINT IDENTIFICATION LABEL

The label (**fig. 4**) is on the inner left edge of the tailgate. It contains the following information:

- A.** Paint manufacturer.
- B.** Name of colour.
- C.** Colour code.
- D.** Indication on the type of product to be used for touching-up.

ENGINE STAMP

The engine marking is stamped on the gearbox side of the crankcase, in correspondence with the exhaust manifold.

ENGINE CODES - BODY VERSIONS

	Engine code	Body versions
1.8 T SPARK	AR32205	937CXR1A 26
2.0 JTS	937A1000	937CXH1A 22
2.0 JTS (for special markets)	932A2000	937CXT1A 29
2.0 JTS Selespeed	937A1000	937CXH11 23
3.2 v6	936A000	937CXP1B 25
JTD 16V	937A5000	937CXN1B 24D

A0A0651b

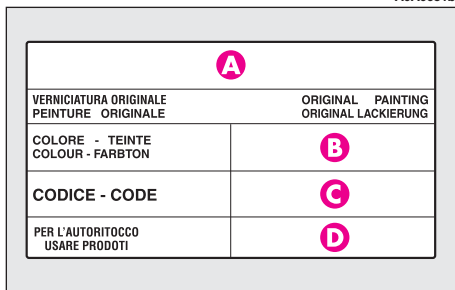

fig. 4

ENGINE

		1.8 T. SPARK	2.0 JTS 2.0 JTS Selespeed	2.0 JTS (**)	3.2 v6	JTD 16V
Code type		AR32205	937A1000	932A2000	936A000	937A5000
Cycle		Otto	Otto	Otto	Otto	Diesel
Number and position of cylinders		4 in line	4 in line	4 in line	6 in 60° V	4 in line
Piston bore and stroke	mm	82.7	83 x 91	83 x 91	93 x 78	82 x 90.4
Total displacement	cm ³	1747	1970	1970	3179	1910
Compression ratio		11.5 : 1	11.5 : 1	11.5 : 1	10 : 1	17.5 : 1
Maximum horsepower (EEC):						
	kW	103	121	119	176,5	110
	HP	140	165	163	240	150
at	rpm	6500	6400	6400	6200	4000
Maximum torque (EEC):						
	Nm	163	206	201	300	305
	kgm	16.6	21	20	30.6	31
at	rpm	3900	3250	3250	4800	2000
Spark plugs (*)		NGK PFR6B+ NGK PMR7A NGK BKR6EKPA+ NGK PMR7A	NGK PFR6B NGK BKR6EKPA	NGK PFR6B NGK BKR6EKPA	NGK PFR6B	
Fuel		Unleaded petrol 95 RON	Unleaded petrol 95 RON	Unleaded petrol 95 RON	Unleaded petrol 95 RON	Diesel fuel for motor vehicles (Specification EN 590)

(*) There are two different spark plugs for each cylinder, one per type (**) For versions/markets where applicable



To change plugs contact Alfa Romeo Authorized Services.

FUEL SUPPLY

	1.8 T. SPARK	2.0 JTS	3.2 v6	JTD 16V
Supply	Multipoint electronic injection	Direct electronic injection	Direct electronic injection	Common Rail direct injection with supercharging



Alterations or repairs to the fuel supply system carried out incorrectly and without taking account of the technical features of the system, may cause operating faults with the risk of fire.

TRANSMISSION

	1.8 T. SPARK	2.0 JTS	2.0 JTS Selespeed	3.2 v6	JTD 16V
Gearbox	Five forward gears plus reverse with synchronisers for forward speeds	Five forward gears plus reverse with synchronisers for forward speeds	Five forward gears and reverse with electronic control system	Six forward gears plus reverse all synchronised	Six forward gears plus reverse all synchronised
Clutch	Dry single disk with hydraulic control	Dry single disk with hydraulic control	Dry single disk with electrohydraulic control	Dry single disk with hydraulic control	Dry single disk with hydraulic control
Drive	Front	Front	Front	Front	Front

FRONT WHEEL DRIVE WITH SELF-LOCKING DIFFERENTIAL (upon request for versions/markets where applicable)

Alfa Q2 characteristics are such as to guarantee top performance with whatever road condition.

Alfa Q2 features front wheel drive with front mechanical self-locking differential LSD (Limited Slip Differential). Torque level between right and left wheel is modulated according to the **TORSEN B** front differential grip. Mechanical modulation is continuous and gradual thus optimizing drive under whatever running condition and guaranteeing smooth drive, high stability and keeping top comfort conditions.

This type of differential enables to exploit the tyre-road grip at the best even under poor grip conditions: the driver is however charged with observing common safety rules since road safety is always the driver's responsibility.

BRAKES

1.8 T. SPARK - 2.0 JTS - 3.2 v6 - JTD 16V

Service brakes:

– front Disk

– rear Disk

Parking brake

Controlled by hand lever, acting on the rear brakes

SUSPENSION

1.8 T. SPARK - 2.0 JTS - 3.2 v6 - JTD 16V

Front

quadrilateral system with stabiliser bar

Rear

Mc Pherson type

STEERING SYSTEM

1.8 T. SPARK - 2.0 JTS - 3.2 v6 - JTD 16V

Type

rack and pinion with hydraulic power steering

Turning radius
(between pavements) m

11.5

WHEELS

RIMS AND TYRES

Pressed steel or alloy rims.

Radial tubeless tyres.

The log book shows all the homologated tyres.

IMPORTANT In the event of any discrepancies between this Handbook and the vehicle Log Book, only the latter should be considered.

While the specified dimensions remain the same, for driving safety, the vehicle must be fitted with tyres of the same brand and type on all wheels.

IMPORTANT Do not use inner tubes with Tubeless tyres.

COMPACT SPARE WHEEL

Pressed steel rim.

WHEEL GEOMETRY

Front wheel toe-in measured from rim to rim: -1 ± 0.6

The values refer to the vehicle travelling.

CORRECT TYRE READING

(fig. 5)

Below, please find the instructions needed to understand the meaning of the code stamped on the tyre.

The code may be in one of the ways given in the example.

Example:
205/55 R 16 91 W
 or
205/55 ZR 16

- 205** = Nominal width (**S**, distance in mm between sides).
- 55** = Percentage height/width (**H/S**) ratio.
- R** = Radial tyre.
- ZR** = Radial tyre, with speed over 240 km/h.
- 16** = Rim diameter in inches (\emptyset).
- 91** = Load index (capacity), e.g. 91 = 615 kg. Not present in ZR tyres.
- W, Z** = Maximum speed index. In ZR tyres the speed index Z is before the R.

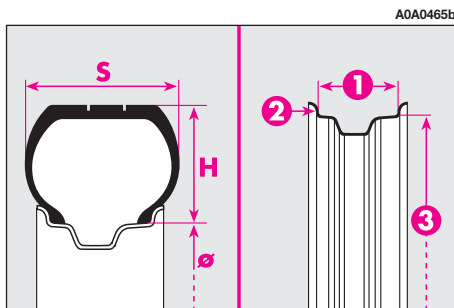

fig. 5

Load index (capacity)

60 = 250 kg	85 = 515 kg
61 = 257 kg	86 = 530 kg
62 = 265 kg	87 = 545 kg
63 = 272 kg	88 = 560 kg
64 = 280 kg	89 = 580 kg
65 = 290 kg	90 = 600 kg
66 = 300 kg	91 = 615 kg
67 = 307 kg	92 = 630 kg
68 = 315 kg	93 = 650 kg
69 = 325 kg	94 = 670 kg
70 = 335 kg	95 = 690 kg
71 = 345 kg	96 = 710 kg
72 = 355 kg	97 = 730 kg
73 = 365 kg	98 = 750 kg
74 = 375 kg	99 = 775 kg
75 = 387 kg	100 = 800 kg
76 = 400 kg	101 = 825 kg
77 = 412 kg	102 = 850 kg
78 = 425 kg	103 = 875 kg
79 = 437 kg	104 = 900 kg
80 = 450 kg	105 = 925 kg
81 = 462 kg	106 = 950 kg
82 = 475 kg	
83 = 487 kg	
84 = 500 kg	

Maximum speed index

Q = up to 160 km/h.
R = up to 170 km/h.
S = up to 180 km/h.
T = up to 190 km/h.
U = up to 200 km/h.
H = up to 210 km/h.
V = over 210 km/h.
ZR = over 240 km/h.
W = up to 270 km/h.
Y = up to 300 km/h.

Maximum speed index for snow tyres

Q M + S = up to 160 km/h.
T M + S = up to 190 km/h.
H M + S = up to 210 km/h.

CORRECT RIM READING

Below, please find the instructions needed to understand the meaning of the code stamped on the rim, as shown in (fig. 5).

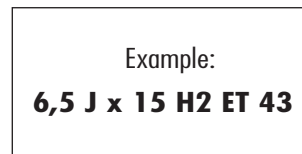

- 6,5** = rim width in inches (1)
- J** = rim drop centre outline (side projection where the tyre bead rests) (2)
- 15** = rim nominal diameter in inches (corresponds to diameter of the tyre to be mounted) (**3** = Ø)
- H2** = "hump" shape and number (relief on the circumference holding the Tubeless tyre bead on the rim).
- ET 43** = camber angle (distance between disk/rim line and wheel rim centre line)

	1.8 T SPARK	2.0 JTS	JTD 16V	3.2 V6	"Black Line" and "Q2" versions	"Collezione" versions
Standard fittings	6 1/2 J x 15 7 J x 16	7 J x 16 7 J x 17 (□)	6 1/2 J x 15 7 J x 16	7 1/2 J x 17	8 J x 18	7 J x 17
Rims	7 J x 17 (□) 7 1/2 J x 17 (□)	7 1/2 J x 17 (□)	7 J x 17 (□) 7 1/2 J x 17 (□)			
Tyres	205/60 R15 91V (●) 205/55 R16 91V (●) 205/55 ZR16 (●) 215/45 R17 87W (□)	205/55 R16 91W (●) 205/55 ZR16 (●) 215/45 R17 87W (□)	205/60 R15 91V (●) 205/55 R16 91W (●) 205/55 ZR16 (●) 215/45 R17 87W (□)	225/45 ZR17 91Y (Pirelli Pzero Rosso) (●) (*) 225/45 ZR17 (Bridgestone S-02) (●) (**)	225/40ZR 18 92Y (●) (Michelin Pilot Sport2) (*) 225/40 ZR 18 92Y (●) (Pirelli P Zero Rosso) (*)	215/45 R 17 87W (●)
Compact spare wheel						
— Rim	4J x 15	4J x 15	4J x 15	(***)	4J x 15	4J x 15
— Tyre	125/80 R15	125/80 R15	125/80 R15		125/80 R15	125/80 R15
Fittings on request	6 1/2 J x 15	6 1/2 J x 15	6 1/2 J x 15		6 1/2 J x 15	6 1/2 J x 15
Rims	7 J x 17 8 J x 18	7 J x 17 8 J x 18	7 J x 17 8 J x 18	7 1/2 J x 17 8 J x 18	7 J x 16 7 J x 17	7 J x 16 8 J x 18
Tyres	195/60 R15 88V (**) 215/45 R17 87W (●) 215/45 ZR17 87W (Pirelli P7000) (●) (*) 215/45 ZR17 87Y (Good Year Eagle F1) (●) (*) 225/40 ZR18 92Y (Michelin Pilot Sport 2) 225/40 ZR 18 92Y (●) (Pirelli P Zero Rosso) (*) (●) (*) 205/60 R15 91V (Michelin Pilot Primacy) (●) (*)	195/60 R15 88V (**) 215/45 R17 87W (●) 215/45 ZR17 87W (Pirelli P7000) (●) (*) 215/45 ZR17 87Y (Good Year Eagle F1) (●) (*) 225/40 ZR18 92Y (Michelin Pilot Sport 2) (●) (*) 225/40 ZR 18 92Y (●) (Pirelli P Zero Rosso) (*)	195/60 R15 88V (**) 215/45 R17 87W (●) 215/45 ZR17 87W (Pirelli P7000) (●) (*) 215/45 ZR17 87Y (Good Year Eagle F1) (●) (*) 225/40 ZR18 92Y (Michelin Pilot Sport 2) 225/40 ZR 18 92Y (●) (Pirelli P Zero Rosso) (*) (●) (*) 205/60 R15 91V (Michelin Pilot Primacy) (●) (*)	215/45 R17 87W (**) 215/45 R17 87W (Pirelli P7000) (*) (**) 215/45 ZR17 87Y (Good Year Eagle F1) (*) (**) 225/40 ZR18 92Y (Michelin Pilot Sport 2) (●) (*) 225/40 ZR 18 92Y (●) 225/40 ZR 18 92Y (●) (Pirelli P Zero Rosso) (*)	195/60 R15 88V (**) 205/55 R16 91V (●) 215/45 R17 87W (●)	195/60 R15 88V (**) 205/55 R16 91V (●) 225/40 R18 92Y (●) (Michelin Pilot Sport2) (*) 225/40 ZR18 92Y (●) (Pirelli P Zero Rosso) (*)
Winter tyres	195/60 R15 88Q (M+S) 205/55 R16 91T (M+S) 215/45 R17 87H (M+S)	195/60 R15 88Q (M+S) 205/55 R16 91T (M+S) 215/45 R17 87H (M+S)	195/60 R15 88Q (M+S) 205/55 R16 91T (M+S) 215/45 R17 87H (M+S)	215/45 R17 87H (M+S) 225/45 ZR17 91H (M+S)	195/60 R15 88Q (M+S) 205/55 R16 91T (M+S) 215/45 R17 87H (M+S)	195/60 R15 88Q (M+S) 205/55 R16 91T (M+S) 215/45 R17 87H (M+S)

(●) Unchainable tyres (□) For versions/markets where applicable (*) Size certified and admitted only for the specified tyres
 (***) **IMPORTANT** Tyres that can be fitted with chains; see paragraph "Snow chains" in section "Correct use of the car"
 (***) The compact spare wheel cannot be used on this version

COLD TYRE INFLATION PRESSURE

Tyres		reduced load		full load	
		front	rear	front	rear
195/60 R15	bar	2.2	2.2	2.5	2.5
205/60 R15	bar	2.3	2.3	2.6	2.6
205/55 R16	bar	2.3	2.3	2.6	2.6
205/55 ZR16	bar	2.3	2.3	2.6	2.6
215/45 R17	bar	2.4	2.3	2.7	2.6
225/45 ZR17	bar	2.5	2.4	2.8	2.7
225/40 ZR18	bar	2.5	2.4	2.8	2.7
Compact spare wheel					
125/80 R15	bar	4.2		4.2	

With the tyre hot the inflating pressure should be +0.3 bar compared with the specified rating

With winter tyres the inflation pressure should be +0,2 bar compared with the specified rating

PERFORMANCE

	1.8 T. SPARK	2.0 JTS Selespeed	2.0JTS	3.2 v6	JTD 16V
Maximum speed in km/h	200	216	216	243	209

DIMENSIONS

The sizes are in mm and refer to the car fitted with standard tyres.

Slight changes with optional tyres.

Height with unladen vehicle.

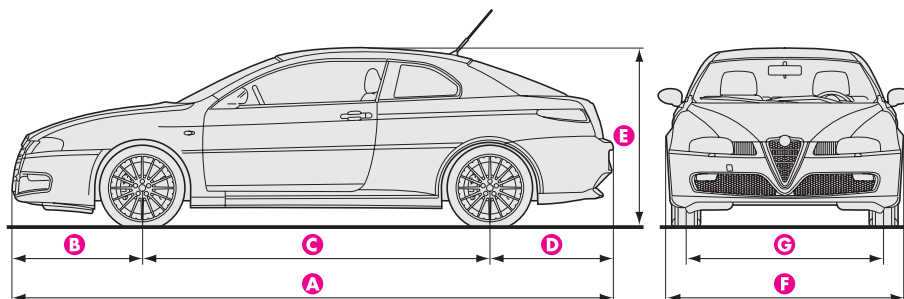

LUGGAGE COMPARTMENT VOLUME

Capacity 320 dm³

Capacity with rear seat back rest folded 905 dm³

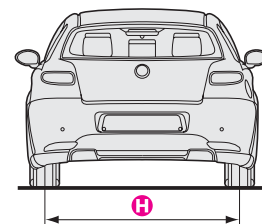
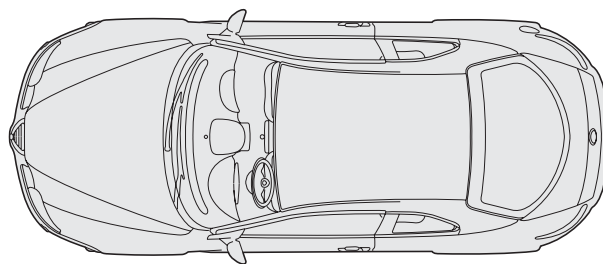

fig. 5

	A	B	C	D	E	F	G	H
1.8 T. SPARK - 2.0 JTS	4489	967	2596	926	1362	1763	1524	1510
3.2 v6	4489	967	2596	926	1355	1763	1524	1510
JTD 16V	4489	967	2596	926	1366	1763	1524	1510

WEIGHTS

		1.8 T. SPARK	2.0 JTS	3.2 v6	JTD 16V
Weight empty (including fluids, 90% fuel in the tank and no optional)	kg	1290	1320	1410	1320
Payload (*) including driver	kg	520	520	520	520
Max permissible weights (**):					
– front axle	kg	980	980	1040	990
– rear axle	kg	980	980	980	980
– total	kg	1810	1840	1930	1885
Towable weights:					
– braked trailer	kg	1300	1300	1400	1300
– trailer without brake	kg	400	400	400	400
Maximum load on ball (braked trailer)	kg	60	60	60	60

(*) With special equipment (trailer towing device, etc.) the loadless weight increases, thereby reducing the payload, with regard to the maximum permissible loads.

(**) Loads not to be exceeded. It is the driver's responsibility to place goods in the boot and/or on the loading surface in accordance with the maximum permissible loads.

REFILLING

		1.8 T. SPARK	2.0 JTS	2.0 JTS Selespeed	3.2 v6	JTD 16V	Recommended products and genuine lubricants
Fuel tank: – including a reserve of	litres	63 (▲)	63 (▲)	63 (▲)	63 (▲)	63 (■)	(▲) Unleaded petrol with no less than 95 R.O.N (■) Diesel fuel for motor vehicles (Specification EN590)
	litres	7 (▲)	7 (▲)	7 (▲)	7 (▲)	7 (■)	
Engine cooling system	litres	7.2	7.2	7,2	7.2	7.2	Mixture of distilled water and PARAFLU UP at 50%
Oil sump and filter	litres	4.4 (□)	4.4 (○)	4.4 (○)	5.9 (○)	4.5 (●)	(□) SELENIA 20 K for Alfa Romeo (○) SELENIA RACING (●) SELENIA WR
Mechanical transmission/ differential	litres	2.0	2.0	2.0	2.0	2.0	TUTELA CAR TECHNYX
Selespeed transmission	litres	–	–	0.6	–	–	TUTELA CAR CS SPEED
Hydraulic power steering	litres	1.2	1.2	1.2	1.2	1.2	TUTELA GI/A
Hydraulic brake circuit with ABS	litres	0.52	0.52	0.52	0.52	0.52	TUTELA TOP 4 for Alfa Romeo
Windscreen washer and rearscreen washer fluid reservoir – with headlamp washer	litres	2.5	2.5	2.5	2.5	2.5	Mixture of water and fluid TUTELA PROFESSIONAL SC 35
	litres	4.2	4.2	4.2	4.2	4.2	

FLUIDS AND LUBRICANTS

RECOMMENDED PRODUCTS AND THEIR SPECIFICATIONS

Use	Fluid and lubricant specifications for correct car operation	Genuine fluids and lubricants	Change intervals
Lubricants for petrol engines 1.8 T. SPARK	Synthetic-based oils, grade SAE 10W-40 FIAT 9.55535-G2 qualification	SELENIA 20K for ALFA ROMEO	As per Service Schedule
Lubricants for petrol engines 2.0 JTS - 3.2 v6	Synthetic-based oil, grade SAE 10W-60 FIAT 9.55535-H3 qualification	SELENIA RACING	As per Service Schedule
Lubricants for Multijet engines	Synthetic-based oil, grade SAE 5W-40 FIAT 9.55535-N2 qualification.	SELENIA WR	As per Service Schedule

Should non-genuine products be used, lubricants with minimum ACEA A3 properties for petrol engines and ACEA B4 for Diesel engines are tolerated; in this event top engine performance is not guaranteed.

Using low-quality products, not compliant with ACEA A3 and ACEA B4 properties and specifications could cause engine damages not covered by warranty.

For very cold temperatures, consult Alfa Romeo Authorised Services for the proper **Selenia** product to use.

Use	Fluid and lubricant specifications for correct car operation	Genuine fluids and lubricants	Applications
Lubricants and greases for transmissions	Synthetic-based oil, grade SAE 75W-85 that passes API GL-4 PLUS, FIAT 9.55550	TUTELA CAR TECHNYX	Mechanical gearbox and differential
	Lubricant for automatic transmissions that passes "ATF DEXRON II D LEV" specification	TUTELA GI/A	Hydraulic power steering
	Specific fluid for gear selector electrohydraulic actuators	TUTELA CAR CS SPEED	Selespeed electrohydraulic actuator
	Molibdenum disulphide, lithium soap based grease.	TUTELA STAR 500	CV joints on wheel side
Brake fluid	Synthetic fluid, F.M.V.S.S. n. 116, DOT 4, ISO 4925, SAE J-1704	TUTELA TOP 4 for Alfa Romeo	Brake and clutch hydraulic controls
Protective agent for radiators	Protective with antifreeze action, red colour based on inhibited monoethylen glycol and organic formula, that passes CUNA NC 956-16, ASTM D 3306 specifications	PARAFLU^{UP}	Cooling circuits. Proportion: 50% down to -35° C. Not to be mixed with products having different formulas.
Windscreen and rear window washer fluid	Mixture of alcohol and surfactants CUNA NC 956-11	TUTELA PROFESSIONAL SC 35	To be used diluted or undiluted

FUEL CONSUMPTION

The fuel consumption figures given in the table below are determined on the basis of the homologation tests set down by specific European directives.

The procedures below are followed for measuring consumption:

– **urban cycle:** cold starting followed by driving that simulates urban use of the car;

– **extra-urban cycle:** frequent accelerating in all gears, simulating extraurban use of the car; the speed varies between 0 and 120 km/h;

– **combined consumption:** is calculated weighing about 37% of urban cycle consumption and about 63% of extraurban consumption.

IMPORTANT The type of route, traffic situations, weather conditions, driving style, general conditions of the vehicle, trim level/equipment/accessories, load, presence of a roof rack, use of the climate control system, other situations that affect air drag may lead to different fuel consumption levels than those measured (see “Reducing running costs and environment pollution” in the chapter “Correct use of the car”).

Fuel consumption according to directive 2004/3/EC (litres x 100 km)	1.8 T. SPARK	2.0 JTS	2.0 JTS Selespeed	3.2 v6	JTD 16V
Urban	12.1	12.2	12.2	18.6	8.2
Extraurban	6.4	6.7	6.7	8.7	4.8
Combined	8.5	8.7	8.7	12.4	6.1

CO₂ EMISSIONS

CO₂ emission levels at the exhaust given in the following table refer to combined consumption.

CO₂ EMISSIONS ACCORDING TO 2004/3/EC DIRECTIVE (g/km)

1.8 T. SPARK	2.0 JTS	2.0 JTS Selespeed	3.2 v6	JTD 16V
202	207	207	295	159

DASHBOARD

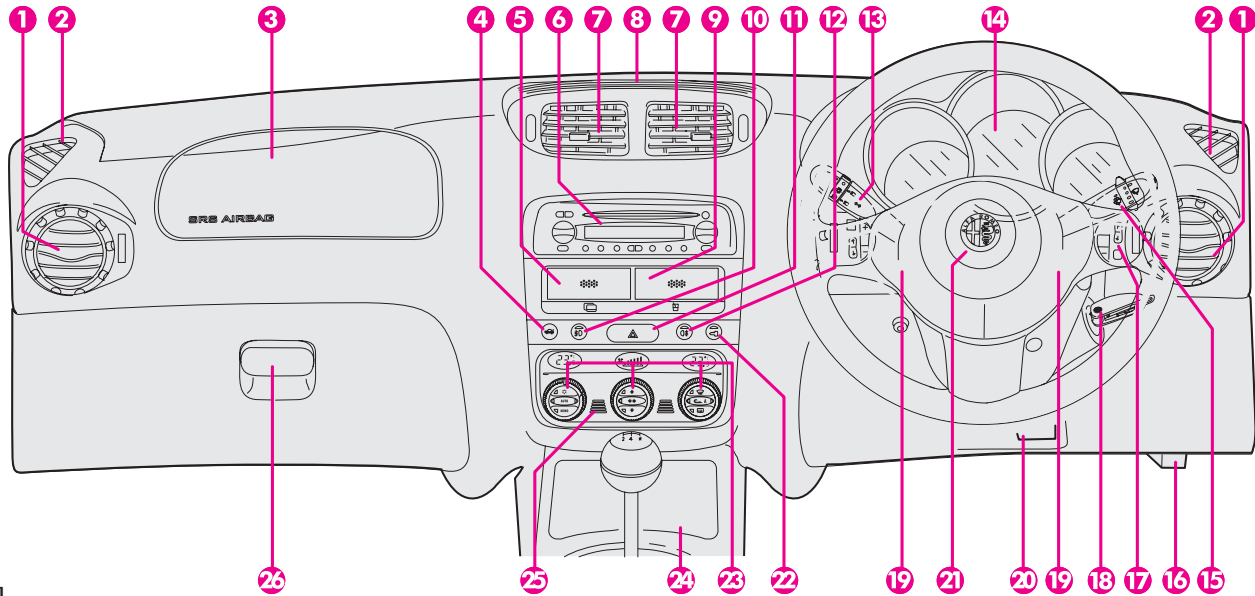

A0A0724b

fig. 1

1. Adjustable side air vents - **2.** Fixed side window air vents - **3.** Front passenger's air bag - **4.** Tailgate release button - **5.** Cards holder (for versions/markets where applicable) - **6.** Sound system (for versions/markets where applicable) - **7.** Adjustable central air vents - **8.** Upper fixed vent - **9.** Glass/can holder (for versions/markets where applicable) - **10.** Front fog light button - **11.** Hazard light switch - **12.** Rear fog light button - **13.** External lights control lever - **14.** Instrument panel - **15.** Windscreen wiper stalk - **16.** Bonnet opening lever - **17.** Set of controls - **18.** Ignition key and ignition switch - **19.** Horn - **20.** Steering wheel locking/release lever - **21.** Driver's air bag - **22.** Door locking button - **23.** Heating/ventilation/climate controls - **24.** Cigar lighter/ashtray housing lid - **25.** Temperature sensor - **26.** Glovebox.

INSTRUMENT PANEL

A. Fuel level gauge with reserve warning light - **B.** Engine coolant fluid temperature gauge with maximum temperature warning light - **C.** Speedometer - **D.** Odometer display (mileage recorder, trip recorder with headlamp position display) - **E.** Reconfigurable multifunction display - **F.** Rev counter

NOTE On JTDM versions the scale bottom is at 6000 revs.

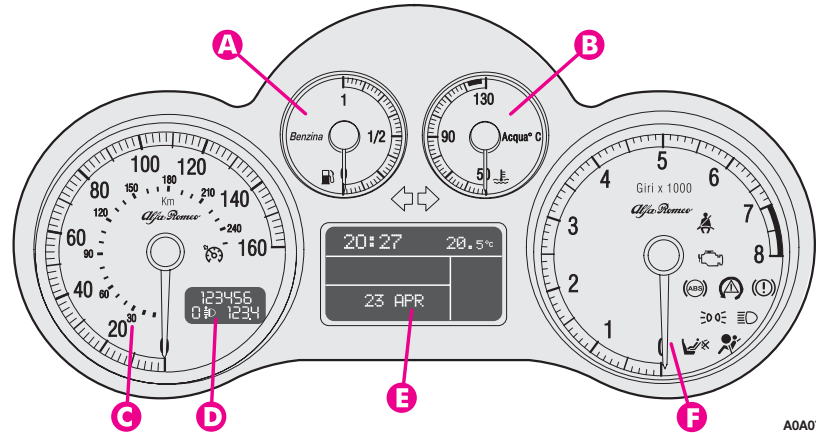

A0A0762b

fig. 2 - Petrol versions

A. Fuel level gauge with reserve warning light - **B.** Engine coolant fluid temperature gauge with maximum temperature warning light - **C.** Speedometer - **D.** Odometer display (mileage recorder, trip recorder with headlamp position display) - **E.** Reconfigurable multifunction display - **F.** Rev counter

NOTE On JTDM versions the scale bottom is at 6000 revs.

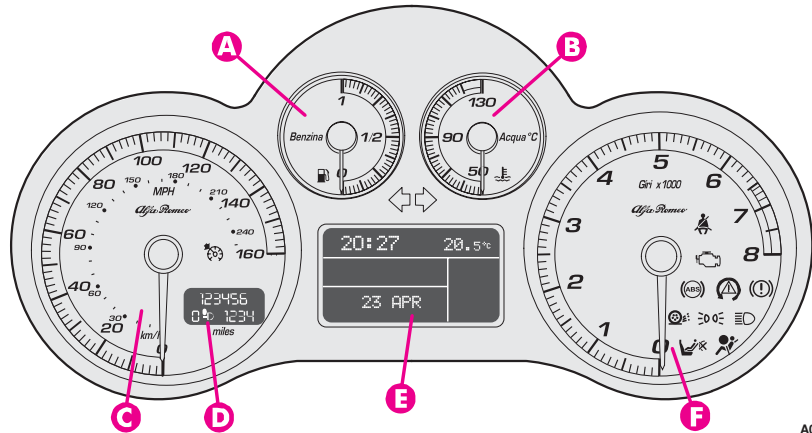

A0A0754b

fig. 3 - Black Line versions

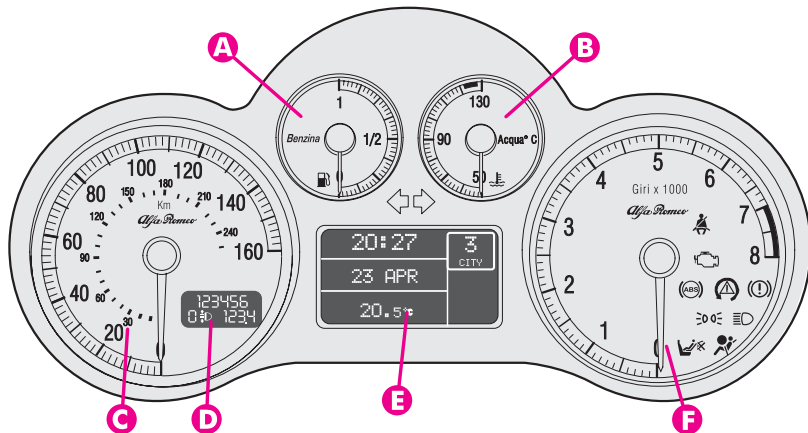

AOA0763b

A. Fuel level gauge with reserve warning light - **B.** Engine coolant fluid temperature gauge with maximum temperature warning light - **C.** Speedometer - **D.** Odometer display (mileage recorder, trip recorder with headlamp position display) - **E.** Reconfigurable multifunction display - **F.** Rev counter

fig. 4 - 2.0 JTS Selespeed versions

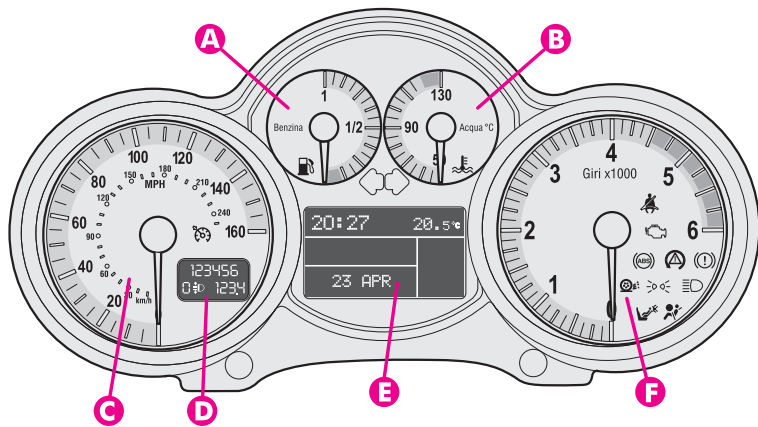

AOA0727b

A. Fuel level gauge with reserve warning light - **B.** Engine coolant fluid temperature gauge with maximum temperature warning light - **C.** Speedometer - **D.** Odometer display (mileage recorder, trip recorder with headlamp position display) - **E.** Reconfigurable multifunction display - **F.** Rev counter

fig. 5 - 3.2 V6 version

INDEX

- A**BS system 134
- Accessories purchased by the user .. 127
- Additional stop light (third stop) 200
- Air bags 38
- Air cleaner 229
- Alfa Romeo CODE 6
- Armrest
- front 17
 - rear 22
- Ashtray
- front 124
 - rear 125
- ASR (system) 138
- B**attery
- advice for preserving the charge 232
 - checking the charge 212-231
 - replacement 232
- Body (maintenance) 236
- Body versions 241
- Bonnet 131
- Boot
- extension 19
 - lighting 129
 - luggage net 22
 - opening from inside 128
 - opening with remotecontrol .. 8-128
 - restraining the load 130
 - tailgate closing 129
 - warnings for carrying luggage ... 130
- Boot light
- changing bulbs 204
- Brakes 245
- Braking lights (third stop)
- changing bulbs 199
- Bulbs
- general instructions 193
 - replacement 192
 - type of bulbs 193
- C**ard and glass holder 125
- Car maintenance** 216
- Cell phones (provision) 126
- Changing a wheel 181-183
- Changing bulbs
- general instructions 192
 - types of bulbs 193
- Checking levels 222
- Cigar lighter 124
- Cleaning and maintenance
- body 236
 - car interior 238
 - engine compartment 238
 - windows 238
- Climate control system 81
- Climate control system, automatic two-zone 89
- Clock 68
- Controls 106
- CO₂ emissions 256
- CODE card 7
- Correct use of the car** 169
- Courtesy light
- changing bulbs 203
- Cruise Control 49

D ashboard	52
Diesel fuel filter	229
Diesel particulate filter (DPF)	167
Digital multifunction display	58
Dimensions	250
Direction indicators	
- changing front bulbs	198
- changing rear bulbs	199
- changing side bulbs	198
- switching on	46
Door locking system	107
Door mirrors	23
Doors	15
E lectronic alarm system	11
Emergency starting	179
- coasting	181
- starting with an auxiliary battery	180
Engine codes/body versions	241
Engine	
- identification codes	241
- marking	241
- specifications	242
Engine compartment	

- bonnet	131
- washing	238
Engine oil consumption	224
Engine starting	169
Environmental protection	168
EOBD (system)	140
External lights (switching on)	44
F irst-aid kit	215
Fix &Go Automatic (device)	186
Flashing high beams	45
Fluids and lubricants	253
Follow me home device	46
Foglights	
- changing bulbs	196
- switching on	106
Front ceiling light	121
- changing bulbs	201
Front fog lights	
- changing bulbs	196
- switching on	106
Fuel consumption	255
Fuel flap	167
Fuel supply	243
Fuses	205

G etting to know your car ...	6
Glove compartment	121
Glove compartment light	
- changing bulbs	203
H andbrake	108
Hazard warning lights	
- switching on	106
Headlamp beam adjustment	108
Headlight washers	49-236
Headlights	
- adjustment abroad	133
- compensation for tilt	108-132
Headrests	
- front	18
- rear	21
Heating and climate control system	81
Hoses	234
I dentification data	240
Ignition device	14
Ignition switch and steering lock	14-15
In an emergency	179

- Inertial fuel cut off switch 107
- Installation of electric/
electronic devices 127
- Instrument cluster 53
- In the event of an accident 215
- Intelligent washing (windscreen) ... 47
- Interior fittings (cleaning) 238
- Internal fittings 121
- K**eys 6
- L**evers (steering wheel) 44
- Lights 44
- Load limiters 29
- Low beam headlights
- changing bulbs 197
- switching on 44-45
- Luggage restrainer net 22
- M**ain beam headlights
- changing bulbs 197
- switching on 45
- Maintenance
- additional operations 229
- annual inspection programme ... 219
- scheduled maintenance 216
- scheduled maintenance
programme 217
- Manual heater 83
- Mechanical gearbox 109
- N**umber plate lights
- changing bulbs 200
- O**ddment recesses 126
- P**aintwork 237
- Parking 172
- Parking sensor 105
- Performance 249
- Pockets 125
- Pollen filter 230
- Power windows 24
- Pretensioners 28
- Puddle lights 123
- changing bulbs 201
- R**adio transmitters and cellular
telephones 127
- Radio 141
- Rain sensor 48
- Raising the car 214
- Rear ceiling light 123
- changing bulbs 202
- Rear fog guards
- changing bulbs 199
- switching on 106
- Rearview mirror 23
- Reconfigurable multifunction
display 61
- Reducing running costs 172
- Refuelling 166-252
- Remote control 7
- Rev counter 56
- Reversing light
- changing bulbs 199
- Rims 247
- S**eat belts 26
- carrying children safety 31
- front belt height adjustment 27
- general instructions 29
- load limiters 29
- maintenance 31
- pretensioners 28

- rear centre lap belt	27	- Fix&Go automatic	186
- use of belts	26	- inflating pressure	249
Seats		- replacement	181
- front	16	- snow chains	177
- rear	19	- types of tyres and rims	247
Selespeed gearbox	110	- winter	177
Sidelights		V DC system	136
- changing front bulbs	197	Vehicle inactivity	178
- changing rear bulbs	199	W arning lights and messages	72
- switching on	45	Weights	251
Snow chains	177	Wheel geometry	246
Speedometer	56	Wheels and tyres	233-246
Steering lock	15	Windscreen washer	
Steering system	245	- intelligent washing function	47
Steering wheel	22	- operation	47
Sun visors	126	- spray jets	235
Suspensions	245	Windscreen wiper	
Symbols	5-6	- blade replacement	235
Technical specifications	240	- operation	47
Towing the car	213	- rain sensor	48
Towing trailers	174	- spray jets	235
Transmission	243		
Tyres			
- correct reading	246		

PROVISIONS FOR THE PROCESSING OF A VEHICLE AT THE END OF ITS LIFE-CYCLE

For years now Alfa Romeo has been developing its global commitment towards the safeguarding and protection of the Environment through the continuous improvement of its production processes and the making of increasingly more “eco friendly” products. With a view to guaranteeing the best possible service to clients in full observance of environmental standards and in response to the obligations imposed by European Directive 2000/53/EC on end-of-life vehicles, Alfa Romeo offers its clients the possibility to hand in their vehicle* at the end of its life span without additional costs.

The European Directive, in fact, provides for the take-back of the vehicle without the last holder or owner of the same incurring expenses due to the fact that the market value of the vehicle is zero or negative. In particular, in almost all of the countries of the European Union, up until 1st January 2007, take-back of the vehicle free of charge only applies to vehicles registered from 1 July 2002 on, while, from 2007 on, take-back will be carried out free of charge, independently of the year of registration, provided that the vehicle still contains all its essential component parts (especially engine and body) and is free from additional waste materials.

Our contracted network of authorised treatment facilities has been carefully selected in order to provide a quality service to our customers by de-polluting and recycling “End of Life Vehicles” to approved environmental standards. To find out the location of your nearest authorised treatment facility, offering free of charge take-back, simply contact one of our dealers or refer to the Alfa Romeo web site or call the toll free number 00800 2532 0000.

* Passenger transportation vehicles to seat a max. of nine persons, having a total admissible weight of 3.5 t

NOTES



A series of 20 horizontal dotted lines, evenly spaced, extending across the width of the page, intended for writing notes.

SELENIA®

***In the heart of those who race.
At the heart of your engine.***



Always ask your mechanic for **SELENIA®**

Your car is factory filled with Selenia

*The engine of your car is factory filled with **Selenia**. This is an engine oil range which satisfies the most advanced international specifications. Its superior technical characteristics allow **Selenia** to guarantee the **highest performance** and **protection of your engine**.*

The Selenia range includes a number of technologically advanced products:

SELENIA STAR

High performance lubricant developed to protect the engine even when operated at the most extreme temperatures generated during sports style driving. Its unique formulation maximizes the performance of high specific power engines, improves cold starting and maintains constant viscosity levels during oil change intervals. Specific Selenia formulation for Alfa Romeo.

SELENIA 20K Alfa Romeo

It guarantees maximum wear protection and performance of aspirated, turbo charged and multivalve engines. Specific Selenia formulation for Alfa Romeo.

SELENIA RACING

This lubricant has been developed as a result of Selenia's extensive experience in track and rally competitions, it maximises engine performance in all kinds of competition use.

SELENIA DIGITECH

Fully synthetic lubricant for petrol and diesel engines. Its advanced technology guarantees maximum protection, a reduction of consumption and reliability in extreme climate conditions.

SELENIA WR

Oil specifically designed for common rail and Multijet engines. Particularly effective during cold starts, it guarantees maximum wear protection and hydraulic tappets control, reduction in consumption and stability at high temperatures.

The range also includes Selenia 20K, Selenia TD, Selenia Performer Multipower and Selenia Performer 5W-40.

For further information on Selenia products visit the web site www.fl-selenia.com.

COLD TYRE INFLATION PRESSURES

Tyres		reduced load		full load	
		front	rear	front	rear
195/60 R15	bar	2.2	2.2	2.5	2.5
205/60 R15	bar	2.3	2.3	2.6	2.6
205/55 R16	bar	2.3	2.3	2.6	2.6
205/55 ZR16	bar	2.3	2.3	2.6	2.6
215/45 R17	bar	2.4	2.3	2.7	2.6
225/45 ZR17	bar	2.5	2.4	2.8	2.7
225/40 ZR18	bar	2.5	2.4	2.8	2.7
Compact spare wheel (*)					
125/80 R15	bar	4.2		4.2	

With the tyre hot the inflating pressure should be +0.3 bar compared with the specified rating

With winter tyres the inflation pressure should be +0.2 bar compared with the specified rating

(*) The compact spare wheel cannot be used on 3.2 v6 version

ENGINE OIL REPLACEMENT

Oil sump and filter (1.8 T. SPARK - 2.0 JTS) litres 4.4

Oil sump and filter (3.2 v6) litres 5.9

Oil sump and filter (JTD 16v) litres 4.5

Do not discard used oil in the environment.

REFUELLING

Fuel tank capacity..... litres 63

Reserve..... litres 7

Only refuel petrol engines with unleaded petrol with octane rating (RON) not less than 95.

Only refuel diesel engines with diesel fuel for motor vehicles (Specification EN590).



SERVICE

CUSTOMER SERVICES

TECHNICAL SERVICES - SERVICE ENGINEERING

Largo Senatore G. Agnelli, 5 - 10040 Volvera - Torino (Italia)

Fiat Group Automobiles S.p.A.

Print No. 60431933 - 1st Edition - 05/2008

All rights reserved. Reproduction, even in part is prohibited without written permission from Fiat Group Automobiles S.p.A.

ENGLISH

Alfa Romeo 
SERVICE