

4

CONFERENCE PROCEEDINGS No. 25

AD 669417
CONFERENCE PROCEEDINGS No. 25

AGARD

ADVISORY GROUP FOR AEROSPACE RESEARCH & DEVELOPMENT

64 RUE DE VARENNE PARIS 7^E FRANCE

Behavioural Problems in Aerospace Medicine

★

OCTOBER 1967

DDC
RECEIVED
JUN 3 1968
E

NORTH ATLANTIC TREATY ORGANIZATION



... release and sale; ...
distribution is unlimited.

Reproduced by the
CLEARINGHOUSE
for Federal Scientific & Technical
Information Springfield Va. 22151

AD 669 417

BEHAVIOURAL PROBLEMS IN AEROSPACE MEDICINE

Advisory Group for Aerospace Research and Development
Paris, France

October 1967

BLANK PAGE

AD669417

NORTH ATLANTIC TREATY ORGANIZATION
ADVISORY GROUP FOR AEROSPACE RESEARCH AND DEVELOPMENT
(ORGANISATION DU TRAITE DE L' ATLANTIQUE NORD)

BEHAVIOURAL PROBLEMS IN
AEROSPACE MEDICINE

OCTOBER 1967

Papers presented at the Twenty-Fourth Meeting of the Aerospace Medical Panel of AGARD,
held in Rhode-Saint-Genèse, Belgium, 25-27 October 1967

613.69:159.943



*Printed by Technical Editing and Reproduction Ltd
Harford House, 7-9 Charlotte St. London. W. 1.*

SUMMARY

The 24th Meeting of the AGARD Aerospace Medical Panel, which was held from 25th to 27th October, 1967, dealt essentially with behavioural problems of aerospace medicine, with particular reference to such aspects as diurnal rhythms, sleep and alertness. Recent medical problems of space and of air warfare were also considered.

It was particularly in the section on human factors in air weapons systems that the subject of sleep and wakefulness, based on a twenty-four hour cycle, was considered in relation to man's performance. Emphasis was placed on the practical aspect of these circadian problems, particularly in relation to associated changes in reaction time and mental performance, and in relation to civil and military flying. The quality of sleep, and the biochemistry underlying the choice of sleep-inducing drugs, formed part of this programme of communications.

Other subjects, such as quantifying biological effects of cosmic radiation, and the ability to walk in a lunar environment, as tested by the Langley sub-gravity simulator, formed part of the section dealing with current problems of space, while the communications in the remainder of the meeting drew attention to a variety of other topics, many of which were orientated towards a specialist audience.

Of immediate application to the operational users, however, mention should be made of the papers dealing with the development and provision of protective clothing for aircrew in hot, humid environments, the development and trial of flashblindness spectacles, a particular type of aircrew selection test, and the effect of a five weeks' stay at 2,250 metres altitude on some aspects of pulmonary function.

RESUME

La 24ème Reunion de la Commission de la Médecine Aérospatiale tenue du 25 au 27 octobre 1967 a étudié essentiellement les problèmes de comportement dans le domaine de la médecine aérospatiale, en rappelant en particulier les aspects tels que les rythmes diurnes, le sommeil et la vigilance. Les problèmes de la médecine aérospatiale récemment rencontrés et les problèmes médicaux de la lutte aérienne ont également été évoqués.

Dans la partie du programme consacrée à l'étude des facteurs humains qui interviennent dans l'utilisation des systèmes d'armes d'avion, on a examiné en particulier la question du sommeil et de la vigilance suivant un cycle de 24 heures, en fonction de la capacité fonctionnelle de l'homme. On a souligné l'aspect pratique de ces problèmes circadiens, surtout en ce qui concerne les variations du temps de réaction et de la capacité mentale qui en résultent, et du point de vue du vol sur les avions civils et militaires. La qualité du sommeil et la biochimie servant de base du choix des substances pharmaceutiques provoquant le sommeil ont figuré sur le programme de communications présentées dans cette partie.

D'autres thèmes, comme les effets biologiques quantifiants du rayonnement cosmique et la possibilité de se promener dans un environnement lunaire, ainsi qu'il a été essayé dans le simulateur d'apesanteur de Langley, ont fait l'objet des communications traitant des problèmes actuels de l'espace. Les mémoires qui ont suivi ont attiré l'attention sur diverses autres questions, dont plusieurs destinées à une assistance spécialiste.

Toutefois, étant donné qu'ils sont directement applicables par les utilisateurs, il faut signaler les mémoires qui ont porté sur les problèmes suivants: mise au point et fourniture de vêtements de protection pour le personnel navigant ayant à travailler dans des conditions de chaleur et d'humidité élevées; mise au point et expérimentation de lunettes anti-lueur; type particulier d'essai permettant de sélectionner le personnel navigant; effets sur quelques aspects de la fonction pulmonaire d'un séjour de cinq semaines à 2.250 mètres d'altitude.

CONTENTS

	Page
SUMMARY	iii
RESUME	iv
INTRODUCTORY REMARKS	viii
WELCOMING ADDRESSES	ix
	Reference
DESYNCHRONISATION AND RESYNCHRONISATION OF HUMAN CIRCADIAN RHYTHMS by Jürgen Aschoff	1
CIRCADIAN RHYTHMS AND MILITARY MAN by Clyde H. Kratochvil	2
THE USE OF PERIOD ANALYSIS TO EVALUATE HUMAN PHYSIOLOGICAL AND PSYCHOMOTOR PERFORMANCE by Michael McCally	3
PERIODIC VARIATIONS IN INDICES OF HUMAN PERFORMANCE, PHYSICAL FITNESS, AND STRESS RESISTANCE by K. E. Klein, H. M. Wegmann and H. Brüner	4
PILOT RESPONSE UNDER GROUND SIMULATION CONDITIONS AND IN FLIGHT by A. M. Hammerton Fraser, J. M. Rolfe and E. M. B. Smith	5
METHODS USED AT AMRD IN THE STUDY OF NORMAL SLEEP AND DRUG-INDUCED SLEEP ON A VISUAL ALERTNESS TEST by R. D. Squires, M. D. and W. C. Sipple	6
THE EFFECTS OF NORMAL SLEEP AND DRUG-INDUCED SLEEP ON A VISUAL ALERTNESS TEST by R. J. Oleynik, M. D. and R. D. Squires	7
NOREPINEPHRINE AND SEROTONIN EFFECTS ON SLEEP, ALERTNESS, AND TEMPERATURE REGULATION by Thomas J. Crowley	8
ELECTROCARDIOGRAPHIC SURVEY OF ROUTINE DUTY DAYS IN HELICOPTER PILOTS by W. P. Schane	9

Reference

THE MORBIDITY OF ARMY AVIATORS. A PRELIMINARY STUDY by R. Bailey	10
ETUDE DE LA VIGILANCE ET DES REACTIONS PSYCHOMOTRICES SUR DES PRIMATES PLACES EN VOL BALISTIQUE by G. Chatelier and Dr. Belugou	11
RECENT WORK ON OXYGEN RICH FIRES by D. M. Denison	12
HUMAN-FACTORS ASPECTS OF ORBITAL OPERATIONS by A. W. Vogeley	13
STATUS REPORT ON RECENT LANGLEY STUDIES OF LUNAR AND SPACE STATION SELF-LOCOMOTION by Donald E. Hewes	14
AREAS OF COINCIDENCE IN AEROSPACE AND SUBMARINE MEDICAL RESEARCH by Charles F. Gell	15
ETUDE DE L' ACTION BIOLOGIQUE DES RAYONS COSMIQUES - AU MOYEN DE BALLONS SONDES par A. Pfister, G. Deltour, H. Atlan, R. Kaiser et L. Miro	16
THE RADIOBIOLOGICAL HIATUS IN SPACE by E. R. Ballinger	17
SLEEP REQUIREMENTS DURING MANNED SPACE FLIGHT by Louis F. Johnson, Jr	18
SYSTEMATIC EVALUATION OF THERMAL ASPECTS OF AIR CREW PROTECTIVE SYSTEMS by Ralph F. Goldman	19
AIR CREW PROTECTIVE TECHNIQUES FOR HOT HUMID ENVIRONMENTS by R. Gaudio, M. McCally, W. C. Kaufman and N. Abramson	20
RECENT ADVANCES IN THE DEVELOPMENT OF MEDICAL EQUIPMENT AND MATERIEL FOR MILITARY AEROSPACE OPERATIONS by John E. Murphy and Bruce H. Warren	21
FLASH BLINDNESS - DEVELOPMENT AND TRIALS OF PROTECTIVE SPECTACLES by Bryan St. L. Liddy and Clement McCulloch	22
A REVIEW OF SOME RECENT AND CURRENT EXPLORATORY DEVELOPMENT EFFORTS IN PRESSURE SUIT TECHNOLOGY by Erwin R. Archibald	23

	Reference
ETUDE DES VALEURS NORMALES DE LA CAPACITE VITALE ET DU VOLUME EXPIRATOIRE MAXIMUM/SECONDE CHEZ LE PERSONNEL NAVIGANT DE LA FORCE AERIENNE BELGE par J. Bande	24
ANALYSE MATHEMATIQUE DU TRACE DE L'EPREUVE D'EXPIRATION FORCEE par J. Clement et K. Van De Woestyne	25
ETUDE CRITIQUE ET STATISTIQUE DE LA VALEUR DE DIVERS TESTS D'ATTENTION UTILISES POUR LA SELECTION DES PILOTES par Paul Lievens	26
BEHAVIOUR OF PULMONARY VENTILATION AND ALVEOLAR GASES TENSIONS IN ATHLETES, BEFORE, DURING, AND AFTER A FIVE WEEKS STAY AT THE ALTITUDE OF 2250 m by A. Scano and G. Meineri	27
A THERMAL MODEL FOR RETINAL DAMAGE INDUCED BY PULSED LASERS by Jude R. Hayes and Myron L. Wolbarsht	28
MECHANISMS OF INJURY FROM VIBRATION by D. J. Sass, J. R. Hayes and D. E. Goldman	29
BALLISTOCARDIOGRAPHIC DETERMINATION OF STROKE VOLUME AND CARDIAC PERFORMANCE by H. W. Kirchhoff	30
	Page
CONCLUDING REMARKS BY THE PANEL CHAIRMAN	1
CLOSING REMARKS BY BRIG. GEN. E. A. LAUSCHNER	3
TECHNICAL EVALUATION	4
LIST OF PARTICIPANTS	7
DISTRIBUTION	

INTRODUCTORY REMARKS

by

Air Commodore H. L. Roxburgh, RAF

Chairman of the Aerospace Medical

Panel of AGARD

Ladies and Gentlemen,

It is my privilege as Chairman of the Aerospace Medical Panel to open this 24th Meeting of the Panel. Before we get down to the scientific sessions, it is my pleasure to introduce to you certain of our hosts who have made this meeting possible: General Ceuppens, who is Chief of Staff of the Belgian Air Force; Mr Dietz, who is Director of the von Karman Institute for Fluid Dynamics and who is our immediate host in this building; Professor Haus, who is the senior Belgian national delegate to AGARD, and who is a member of the Board of Direction of the von Karman Institute, and finally Mr. Franklin J. Ross, who is the Director of AGARD.

The first scientific session will be chaired by General Evrard, who requires no introduction from me. I would like to add here that, along with the other hosts, we must regard General Evrard as one of the mainstays of the Aerospace Medical Panel for many years, and who is also Belgian national delegate to AGARD.

WELCOMING ADDRESSES

Lieutenant General J. Ceuppens, DFC,
Chief of Staff of the Belgian Air Force

Gentlemen,

As Chief of Staff of the Air Force, I have the great honour and privilege to welcome you to this country and to the 24th AGARD Meeting.

When General Evrard asked me to deliver this short introductory address, my feelings at first were mixed; to be honest I should say that they were feelings of apprehension. In my dealings with medical men I have, most of the time, been the consumer, and this gives me a fright at least once a year when I undergo my flying fitness examination.

Well, having accepted the honour of meeting this distinguished gathering of doctors and biologists, I asked for the Agenda of your session and then I became very interested indeed. I noted that you are concentrating your attention during three days on such subjects as "Air Weapons Systems", "New Facts in Air Warfare", "Flash Blindness Alertness", "Pilot Performance", etc. I was struck by the operational aspect and by the possibility of immediate military application of all these. In fact, unless I misunderstood the Agenda, your group is bridging the gap between Aerospace Medicine and the realistic and immediate problems interesting the Air Staffs.

Lay people always feel a bit anxious about the academic aspects of scientists' meetings, and the military, as men of action, even share a greater fear in this respect. But this is no longer true when they realise that the specialists, the doctors and the engineers, approach the solutions of the various technical problems that preoccupy the military. I am very happy to note that your investigations are directed towards this aim.

Messieurs,

L'automation et la mécanisation continuent leur expansion au sein des forces armées et particulièrement au sein des forces aériennes. Mais elles ne pourront exclure le rôle primordial de l'homme, de ce que j'appelle la loyauté et le génie du cerveau humain. Des lors, il me semble que le véritable problème est celui de la meilleure adaptation de l'homme aux conditions évoluant de la technique.

Messieurs, j'ai été frappé par le choix de votre lieu de reunion. Vous, medecins, pour vous reunir et pour discuter des aspects médicaux de problèmes militaires opérationnels, vous avez choisi un institut d'ingenieurs ou vous côtoyez des tunnels d'aérodynamique. J'y vois le symbole de la nécessaire coopération du medecin avec l'ingenieur et avec l'aviateur pour réaliser l'adaptation des forces aériennes au progrès de la technique.

Messieurs, j'ai essayé de résumer très brièvement mes vues et sentiments quant à vos travaux. Il me reste à vous souhaiter une session fructueuse et couronnée de succès.

Je vous remercie de votre attention.

Professor F. Haus,
Belgian National Delegate to AGARD,
Member of the Board of Direction of
The von Karman Institute for Fluid Dynamics

As a Belgian national delegate to AGARD and as a retired professor of Flight Mechanics, I have to comply with two duties: to welcome the audience, and especially those coming from abroad, and to say some words about the VKI, but I realise that this has been done by Mr. Dietz.

AGARD Fluid Dynamics Meetings have been held here four or five times. It is nevertheless the first time that the Aerospace Medical Panel meets here. This can be considered as a tribute to von Karman who - as everybody knows - was the founder of AGARD, but who is also the man to whom the Institute owes its present status and - I should say - its existence.

When AGARD was founded in 1952, the first decision was to create four panels:

Wind tunnel panel
Flight test panel
Aeromedical panel
Combustion panel.

von Karman realised that the full utilization of the atmosphere by man needed the collaboration of engineering, physics, chemistry and medicine. The collaboration of all sciences is necessary, and - in any science - the collaboration of workers of all countries.

von Karman was a great humorist. You know he lived and worked in Aachen for twelve years, roughly from 1920 to 1932. He spent then one year or two in Japan and settled at Pasadena, California, in 1934. von Karman never had Belgian students at Aachen, but he got some as soon as he was at Pasadena. He explained this by saying that the political distance between Brussels and Aachen, and especially between Liege and Aachen, was far greater than the political distance from Brussels to Los Angeles. von Karman's concept of political distance corresponded, at that time, to a reality. But NATO has certainly reduced the political distance between Western nations, and for those collaborating in a scientific programme, I dare say there is no political distance at all.

The final aim of AGARD is to increase the military potential of the alliance. This may be obtained by an increase in the efficiency of the machine, and in the efficiency of man.

Some terrible conditions concerning man's efficiency have been described at the Turin AGARD meeting by General de Cumont, Chairman of NATO Military Committee. He recalled the Broussilov offensive of 1916, where the man of the first row alone had a gun, and where the man of the second row had to wait until the man of the first row was killed or wounded in order to get an arm. This seems to be the worst conditions where a warrior may be placed, and the problem of increasing the efficiency of the airman requests now more elaborate conditions than the obvious ones which would have improved the efficiency of the Russian army of 1916. When one looks to the programme of the meeting, one gets the impression that every effort to place the fighting man in a better situation is really made, and that nothing is neglected.

The evolution of aircraft, in half a century, has led us from the Spads, Albatross or Sopwith from the first World War, to the F.104, the F.111 of the present time. The performances have grown fantastically fast. Is there so great a difference between the Guynemers, von Richthoffens and other pilots of the first World War, and the modern astronauts? I am afraid we cannot exert a strong impact on the evolution of men. You must accept man as he is, and this is a heavy limiting condition. The problem is then to improve the efficiency of a very slowly evolving being: it is by a better knowledge of man, by a careful study of his limits and by the research of the best working conditions, that you can improve his efficiency. What a difference with the time when the problem was only to provide a gun to each man!

The engineer has probably an easier task. When he has built a machine, he can always build a more powerful one sometime later. The air battle during the first World War was a race between engine builders. The plane driven by a 150 h.p. engine had a superiority over the plane powered by a 120 h.p. engine, and so we saw air superiority pass from one camp to another due to the fact that one had constructed a 220 h.p. engine some weeks before the opponent. During the second World War, the race was perhaps not so acute, as the factor of mass production was overwhelming, but the appearance of the jet engine was nevertheless an important factor.

In spite of the big technical achievements, the engineer must bow before the medical doctor, whose work is so strongly bounded by limiting conditions: the capabilities of man.

Training may of course prepare a man for a specific task, but training cannot improve the capacities in the same way as the increase of the motor power improves the performance of a plane. In addition, you have strong limitations in experimental possibilities since the life of man may not be endangered by his serving as a guinea pig.

I even feel I have to apologize for the attempts made by engineers to represent (by a mathematical formula) the behaviour of the pilot. The engineers have built successful auto-pilots which comply with a specific and well-defined programme. They have developed a mathematical theory of automatic control. They have now the pretension to describe, by a mathematical formula, the behaviour of a human pilot, and, in 1966, an AGARD meeting was devoted to this question. However, before the theory of automatic control can be usefully extended to the work of a human pilot, there must be more collaboration between the engineers and the physiologists. This requires the efforts of the engineer to understand the medical mind. In the reverse, it is possible that the medical doctors can find some useful suggestions in the laws and facts that the engineers have discovered. I predict even that there will be here a specialist of fluid circulation in tubes who will try to indoctrinate you, and to explain that the experience made in glass or plastic tubes may be of use for the study of liquid flow in the human body.

In any case, the fact that you - surgeons, physiologists - are meeting in a school for aerodynamicists, or more generally speaking, in a school for physicists, is a symbol. The symbol that physics, chemistry, physiology and medicine are only parts of a unique science: the knowledge of the universe.

Mr. R. O. Dietz
Director of The von Karman Institute
for Fluid Dynamics

Welcome to the von Karman Institute! It may seem strange that an Aerospace Medical Panel meets at an Institute involved in teaching and research in fluid dynamics. There are, however, some reasons for a feeling of kinship to exist between our groups. Principally we at the von Karman Institute deal with air. Air cannot be seen. Air cannot be smelt (at least away from Los Angeles) and air cannot be tasted. The equations which describe the flow of air over most surfaces cannot be solved. Thus the fluid dynamicist is somewhat like the doctor who must determine what is happening inside the human machine by observing the outside of the machine. The doctor also makes diagnoses on the basis of symptoms which are given by untrained and sometimes highly imaginative patients. It is clear then that your Group and this Institute deal with sciences which are somewhat less than exact.

There are a couple of more practical reasons why you may find your visit to this Institute worth while. I urge each of you to take advantage of the opportunity to inspect the facilities at the Institute which is scheduled for Thursday afternoon. During this inspection, you will see our Fluidics Laboratory. The scientist in charge there will describe the application of fluidics devices to mechanical heart machines. These devices have made possible one of the partially successful mechanical hearts which have been used with animals. As you will proceed further and look closer into our research programme, you may learn of a study on velocity measuring techniques for non-Newtonian fluids. Our results from such fundamental investigations may be applicable to measurements of blood flow in the human body.

Your use of our conference room and other facilities is a welcome extension to our long-standing relationship of co-operation with AGARD.

Mr. F. J. Ross
Director, AGARD

Ladies and Gentlemen,

May I first of all thank our Belgian hosts for having honoured us with their kind invitation to hold this AGARD meeting here. This is the second time that this Panel has enjoyed generous Belgian hospitality. Thank you very much.

It is my privilege to welcome you, on behalf of AGARD, to the 24th Meeting of the Aerospace Medical Panel. You have kindly accepted the Panel's invitation to present research results on given topics and to discuss present scientific problems and future plans. May I thank especially the speakers for their contributions.

I am pleased to learn from your programme how much you are concentrating on the role of man in present and in future operational environments. The integration of man, especially in advanced operational aerospace systems, requires still more knowledge and adaptation. You are not only providing the knowledge on man's capabilities under different environmental and working conditions, but you are also offering methods of adaptation. Technology is recognising more and more that the human operator is very often the weakest link in a given system, and this must always be taken into consideration. This can only be achieved by co-operation with biosciences.

A programme like yours will improve mutual understanding and inter-disciplinary co-operation, in addition to its value for the aerospace medical activities. Consequently this approach will result in the solution of problems remaining unsolved until now.

I wish to congratulate your Chairman, Air Commodore Roxburgh, on this programme and wish you a successful meeting and an enjoyable stay.

BLANK PAGE

DESYNCHRONIZATION AND RESYNCHRONIZATION
OF HUMAN CIRCADIAN RHYTHMS

by

Jürgen Aschoff

Max-Planck-Institut für Verhaltensphysiologie,
8131 Seewiesen und Erling-Andechs, Germany

SUMMARY

Circadian rhythms of activity, body temperature and urine excretion have been measured in human subjects, kept in isolation in an underground bunker, either in constant conditions or exposed to artificial light-dark cycles. In constant conditions, free-running rhythms synchronous in all functions have been demonstrated as well as cases with internal desynchronization. Entrainment to a 26.7-hour day resulted in changes of phase-angle differences as to be predicted from oscillation theory, whereas exposure to a 22.7-hour resulted in relative coordination between the circadian rhythms and the light-dark cycle only. A group of four subjects, enclosed together into the bunker, showed synchronous circadian rhythms during the first 10 days, thereafter desynchronization between one subject and the rest of the group. Shifts of the artificial light-dark cycle by 6 hours, simulating 'flights' in either eastward or westward direction, were followed by the activity-cycles of the subjects rather immediately; the rhythms of body temperature, however, did not regain their normal phases until several days (up to 10) had elapsed.

NOTATION

- T = Zeitgeber period
- τ = circadian period
- LL = continuous light

DESYNCHRONIZATION AND RESYNCHRONIZATION OF HUMAN CIRCADIAN RHYTHMS*

Jürgen Aschoff

1. INTRODUCTION

In Biology as well as in Medicine, increasing attention is being paid to the fact that there is strong temporal order in all living systems (1,2). The diurnal rhythms provide the most intensively studied examples. They have been described on all levels of organization, from biochemical reactions in the cell up to behavioral patterns of primates. In man, more than 100 functions and structural elements could be named which oscillate between maximal and minimal values once a day. They range from the well known rhythm in deep body temperature to rhythms in mood and in mental performance (3).

As has been shown experimentally, diurnal rhythms are based on endogenous, self-sustained oscillations (4). Under constant conditions, the rhythm continues with its own natural frequency. The period of such a 'free running' rhythm deviates more or less from that of the earth's rotation, i.e. from 24 hours. This is indicated by the term 'circadian', as introduced by Halberg (5). Under natural conditions, circadian rhythms are entrained to 24 hours by the synchronizing effects of periodic factors in the environment, called Zeitgebers. Using artificial Zeitgebers, e.g. an artificial light-dark cycle, it is possible to entrain a circadian rhythm to periods other than 24 hours (within some limits). In this case as well as in the case of a constant environment, the circadian system becomes desynchronized from the periodicity of its natural environment: external desynchronization. In contrast to this, internal desynchronization means that several rhythmic functions within the organism show different periods. Finally, a phase-shift of an artificial Zeitgeber against local time - or a sudden transfer of the organism in westward or eastward direction - may be considered as a type of transient external desynchronization which usually is accompanied by internal desynchronization for some time. For all three types of desynchronization, experimental evidence is given below.

2. EXTERNAL DESYNCHRONIZATION

2.1 Constant conditions

In order to demonstrate free running circadian rhythms in man, it is necessary to exclude from the experimental chamber external cues from which a notion on true time could be derived. In this regard, especial care has to be taken about all kinds of noise. At our institute, an underground bunker containing two separate apartments

* The experiments reported here have been supported by NASA Research Grant Nsg-259-62.

with kitchen and toilet have been in use for several years. When enclosed there in complete isolation and without a time-telling device, a subject continues to show rhythms in wakefulness and sleep as well as in other functions such as urine excretion and body temperature (6). As can be seen from the black bars on the upper margin of Fig. 1, the sleep times drift steadily to the right as compared to the vertical lines (midnight). The subject has a clear circadian period of more than 24 hours. Concurrent with each activity-time (white bars on the upper margin), there is a maximum in body temperature and a maximum in urinary excretion of potassium, sodium and water. This means: Although desynchronized from the natural day-night cycle, the organism is internally still synchronized, all functions showing the same circadian period of about 24.9 hours.

The deviation of the circadian period from 24 hours becomes even more conspicuous in Fig. 2 where data of a second experiment are presented in another manner (7). The horizontal continuous lines represent the time spans when the subject is out of bed (activity-times), the dotted lines the following time spans in bed (rest- or activity-times). Open circles indicate the minima of rectal temperature. The first 6 days show the behavior under normal conditions outside the bunker. The subject is enclosed into the bunker at the 7th day at 16:00. For the first few days in isolation, the period is still close to 24 hours. However, after 8 days of bunker life, the activity-sleep-times as well as the minima of body temperature drift towards later hours each day. At the 17th day of isolation, the subject awakes at 2:00 in the morning, having 'lost' nearly one day. When he then is released from the bunker, he is out of phase with local time by about 6 hours. This difference is nearly fully corrected already the following day with regard to the activity cycle. Body temperature, however, regains its normal phase (i. e. minimum at about 5:00) not until the 8th day after the subject has left the bunker.

The continuation of internal synchronization during a state of external desynchronization does not imply that the phase-map describing the phase-relationship between different rhythmic functions (8), remains unchanged. On the contrary, both, Fig. 1 and Fig. 2, indicate that the free running circadian system is characterized by a minimum of body temperature which coincides with the beginning of sleep-time whereas in the normally entrained organism the minimum of body temperature occurs rather towards the end of sleep-time. These changes in the internal phase-relationship already suggest that the rhythms of body temperature and of activity may be looked upon as separate oscillators (9).

2.2 Entrainment to Odd Days

By using artificial light-dark cycles (including dawn- and dusk-transients in light intensity), it is possible to entrain subjects in the bunker to non-24-hour periods (10). An example is given in Fig. 3. For the first 8 days, the subject is exposed to a 24-hour day with 15 hours of light and 9 hours of darkness. Obviously, the subject belongs to the group of 'late risers', showing a large negative phase-angle difference between his awakening time (onset of horizontal continuous lines) and light-on. The minimum of body temperature (open circles) occurs after the middle of sleep-time (dotted lines). From the 9th day on, the light is turned on and off each day 2.7 hours later; the Zeitgeber period therefore is now 26.7 hours. As a response, the subject reduces his negative phase-angle difference continuously until he eventually awakes at or even before the time of light-on. The diagram also demonstrates that the minima of body

temperature become advanced relative to the activity cycle, eventually coinciding with the end of activity-time rather than with the end of sleep-time. It is not clear from the picture whether a real steady state is reached after 15 Zeitgeber periods.

At day 23, the normal Zeitgeber with a period of 24 hours is re-introduced. In contrast to the first change from a 24 hour to a 26.7-hour period which was not perceived by the subject, this return to a normal period gives the subject the sensation of a change in conditions. Nevertheless, he does not readjust himself immediately. As can be seen from the minima of body temperature, a normal phase-relationship is not regained even after 11 days.

The experiment is concluded with the introduction of a light-dark cycle the period of which is 22.7 hours. The diagram clearly shows that the subject does not follow this short day. He drifts away with a circadian period which, in average, is longer than 24 hours. Therefore, he is crossing through the Zeitgeber several times. During this part of the experiment, the remarkable point is the appearance of 'relative coordination'. By this term, as first used by v.Holst (11) in describing the interaction between fin movements in fishes, it is meant that there is still an influence of the Zeitgeber on the circadian system, however, the influence is not strong enough to produce entrainment. The circadian rhythm, therefore, crosses through the Zeitgeber with a varying speed. Twice, there is an obvious tendency of the rhythm to lock on to the Zeitgeber, but each time the rhythm again drifts away after a few periods.

The whole experiment shown in Fig.3 demonstrates, first, desynchronization from the natural 24-hour period by means of an artificial Zeitgeber, and, second, desynchronization from the Zeitgeber itself. The results could partly have been predicted. The changes in phase-angle difference during entrainment to a 26.7-hour period are to be expected from oscillation theory (12). The failure of entrainment to a 22.7-hour period is not too surprising in the light of the long circadian periods usually shown by human subjects when kept in constant conditions. The results are also in accordance with the findings of Lewis and Lobban (13) who, in their Spitzbergen experiment, observed that adjustment to a 27-hour day was easier and more complete than adjustment to a 21-hour day. Whether or not a subject becomes entrained by a short Zeitgeber period, depends on many factors, including the great interindividual variability of natural periods. That synchronization with a 22-hour day is possible in bunker-type experiment, has recently been demonstrated by Jenner (14).

3. INTERNAL DESYNCHRONIZATION

3.1 More than One Oscillator?

When free running under constant conditions, the phase-map is not necessarily kept in order. It may happen that the rhythm of body temperature and the rhythm of activity and rest have different, non-integral frequencies. An example is given in Fig.4. During the first 15 days of isolation, the subject shows 10 periods in wakefulness and sleep as against 14 periods in body temperature. As a consequence, the minima of body temperature some times occur when the subject is asleep, some times when the subject is awake. This continuous change in the phase-relationship between the two rhythms results in a periodic change of the temperature's amplitude, being large when the maximum coincides with activity, and being small when the maximum coincides with sleep (c.f. for details 6).

During the second half of the experiment shown in Fig. 4, the rhythm of body temperature becomes synchronized with the activity-cycle in a 2:1-ratio (i. e. two minima of body temperature for one cycle in activity and rest; c. f. days 21 to 25). Finally, there is again a 1:1-ratio between the two rhythms both having now unusually long periods of about 50 hours for the last four days. From these and similar results, several conclusions may be drawn: 1) The rhythm of body temperature is not a mere consequence of the rhythm in activity and rest; 2) Both rhythms possibly have to be looked upon as separate oscillators; 3) The two oscillators are normally synchronized with each other in a 1:1-ratio, the phase-angle difference between them depending on the circadian period; 4) The two oscillators may also be entrained with each other in a 1:2-ratio (entrainment by demultiplication; 15), or they may even free run with different frequencies.

It is fair to assume that temporal order as it has been developed by evolution, is a prerequisite for health and efficiency. Since internal desynchronization (disorder) seems to occur in cases of external desynchronization, an environment without Zeitgebers or with improper Zeitgebers may be a hazardous one. There is also evidence that for free running circadian rhythms in man the appearance or non-appearance of desynchronization depends on several circumstances. Among those, electromagnetic fields seem to play a role. As has been shown recently by Wever (16), shielding against natural electric and magnetic fields (as done in one of the two bunker apartments), presumably facilitates internal desynchronization.

3.2 Group Effects

If several subjects are enclosed in the bunker at the same time, they usually all try to keep the same circadian period. In case of two, this is easily done: the superior one leads, and the other one follows. In the case of four subjects, the situation becomes more complex. The diagram in Fig. 5 gives the results of such an experiment (17). During the first 10 days of isolation, the average circadian period of the whole group is 26.2 hours. Three members of the group are also mainly close to each other in their times of getting up. Subject S, however, wakes up about 2 hours earlier than the rest of the group. He has, in technical terms, a leading phase or a positive phase-angle difference to the three other subjects. According to oscillation theory, this indicates that subject S may have a higher natural frequency than the rest of the group.

Two pieces of evidence support the hypothesis that subject S has a rather short natural circadian period. A) During the first 10 days, the rhythm in urine excretion of subject S nearly disappears towards day 5, and it reappears towards day 10. A likely explanation for this phenomenon is that subject S has a rhythm of urine excretion the rhythm of which is shorter than that of the activity-cycle and which has not become entrained to the rather long period of the group's activity-cycle. The rhythm of urine excretion, therefore, shows a beat-phenomenon, being first in phase, then out of phase and finally again in phase with the activity-cycle. (For details, c. f. 17.) B) When, at day 10, the intensity of illumination in the room is reduced from 1400 to 100 lux, the three 'slow' members of the group lengthen their circadian periods by roughly 1 hour. This, obviously, is too much for subject S. After a few days of compromise, he drifts away from the rest of the group with a period which is now close to 24 hours.

The experiments demonstrate 'internal' desynchronization if one considers the group a biological unit, built up by four sub-units. It may also be considered as an example

for external desynchronization in the case of subject S, the rest of the group being a Zeitgeber for S. The data reported here have some bearing on the results of experiments with crews working on a 4:2-hour work-rest cycle. The continuous changes in phase of the still present circadian rhythms, observed in some of these experiments, still need to be explained (c. f. 18).

4. PHASE-SHIFT OF THE ZEITGEBER

It is well known even to the layman that, after a jet flight in eastward or westward direction, it takes several days to become readjusted to local time. The time necessary for resynchronization depends, first of all, on the amount of phase-shift accomplished by the trip. However, the direction of the trip - whether eastward or westward - also influences the duration of re-entrainment. Experiments demonstrating this effect have been made with birds, kept in artificial light-dark cycles (19). 'Flights' are simulated by shortening or lengthening the Zeitgeber period once for several hours. In average, finches are resynchronized with the light-dark cycle (as measured by their activity) in about three days when the Zeitgeber has been shortened once by 6 hours; it takes about twice as long when the Zeitgeber has been lengthened once by 6 hours. This 'asymmetry' of the circadian system is in accordance with theoretical considerations, based on a mathematical model (20).

Similar experiments with human subjects in the bunker have led to similar results (21). The data presented in Fig. 6 show, first, the effects of a 'flight' in eastward direction, and, several days later, the effects of a 'flight' in westward direction on two male subjects, measured independently. In both subjects, the activity-cycle is adjusted to the shifted Zeitgeber immediately or after a very few days only. The minima of body temperature, however, regain their normal phase (in all but one of the shifts) in a slow gradual manner. And in both subjects, the time for re-entrainment of body temperature is longer after the westward 'flight' than it is after the eastward 'flight'.

The afore mentioned rule will, of course, not apply to all individuals. Whether resynchronization takes longer after a westward or after an eastward flight, depends to a large extent on the natural circadian period of the individual concerned. Even finches become resynchronized quicker after a westward flight if they show especially long periods under constant conditions. Since many human subjects tend to have rather long periods under constant conditions, a large percentage of the population probably may resynchronize easier after a flight in westward direction. The main point of interest is that internal desynchronization takes place during re-entrainment after shifts. Several rhythmic functions in one organism differ in the time needed for full resynchronization. Most likely, this internal disorder contributes to the loss in efficiency during the first days following a long-distance flight.

5. CONCLUDING REMARKS

Circadian rhythms are examples of an evolutionary adaptation to time structures in the environment. This process resulted in a) self-sustained oscillations the periods of which match approximately that of the environment, b) species-specific phase-relationships between the oscillations and the environment, warranted by entrainment, and c), temporal order between a multiplicity of oscillating systems. Maintenance of

the temporal order within the organism seems to depend partly on interaction between several oscillators within the organism, and partly on phase-setting effects of the entraining Zeitgeber. Therefore, lack of proper Zeitgebers may have deleterious effects to the organism (22).

Desynchronization from the natural 24-hour period, whether achieved by artificial Zeitgebers or by isolation from all Zeitgebers, does not necessarily comprise internal disorder. However, it results in changes of the internal phase-relationship the consequences of which are not yet known. It further can result in internal desynchronization which one has to expect to be injurious to the organism.

Resynchronization to 24 hours, whether after isolation or after entrainment to odd days, is often accompanied by a transient state of internal desynchronization. The same applies to re-entrainment of an organism after its quick transfer through several time zones. Any attempt to shorten the duration of re-entrainment after shifts or to reduce the loss in efficiency during this time, will depend on a deeper understanding of the underlying circadian mechanism. In several fields of applied physiology, all types of desynchronization mentioned above are of importance. In this regard, especial attention ought to be paid to the interaction between the circadian rhythms of members of a crew as well as to the reaction of a crew to either unusual Zeitgebers or to a shift-work schedule.

REFERENCES

1. Pittendrigh, C.S. The Harvey Lectures, Series 56(1961):93-125. New York, Academic Press.
2. Aschoff, J. Int. J. Biometeorol. (1967) (in press).
3. Mills, J.N. Physiol. Rev. (Wash.) 46(1966): 128-171.
4. Aschoff, J. Ann. Rev. Physiol. 25(1963): 581-600.
5. Halberg, F. Z. f. Vitamin-, Hormon- und Fermentforsch. 10(1959): 225-296.
6. Aschoff, J., U. Gerecke u. R. Wever. Jap. J. Physiol. (1967) (in press).
7. Kriebel, J. Unpublished data.
8. Aschoff, J. Dtsch. Med. Wochenschr. 88(1963): 1930-1937.
9. Aschoff, J., U. Gerecke u. R. Wever. Arch. Ges. Physiol. 295(1967): 173-183.
10. Aschoff, J., E. Pöppel u. R. Wever. Unpublished data.
11. Holst, E. v. Ergbn. Physiol. 42(1939): 228-306.
12. Aschoff, J. Arbeitsgemeinschaft. f. Forschg. des Landes Nordrhein-Westfalen 138(1964): 51-79. Westdeutscher Verlag, Köln.
13. Lewis, P.R. a. M.C. Lobban. Quart. J. Exp. Physiol. 42(1957): 371-386.
14. Jenner, F.A., Goodwin, J.C., Sheridan, M., Tauber, I.J. a. Lobban, M.C., Brit. J. Psychiat. 113(1967) (in press).
15. Bruce, V. Cold Spring Harbor Symp. Quant. Biol. 25(1960): 29-47.
16. Wever, R. Z. vergl. Physiol. 56(1967): 111-128.
17. Pöppel, E. Unpublished data.
18. Aschoff, J. In: Proc. 3rd Int. Symp. Bioastronautics and Exploration of Space. San Antonio 1964, (Ed. Bedwell and Strughold): 564-584.
19. Aschoff, J. u. R. Wever. Z. vergl. Physiol. 46(1963): 321-335.
20. Wever, R. J. theor. Biol. 13(1966): 187-201.
21. Aschoff, J. In: Proc. VII. Int. Space Science Symp. (Wien 1966). North-Holland, Amsterdam (1967): 159-173.
22. Aschoff, J. Symp. Zool. Soc. London. 13(1964): 79-98.

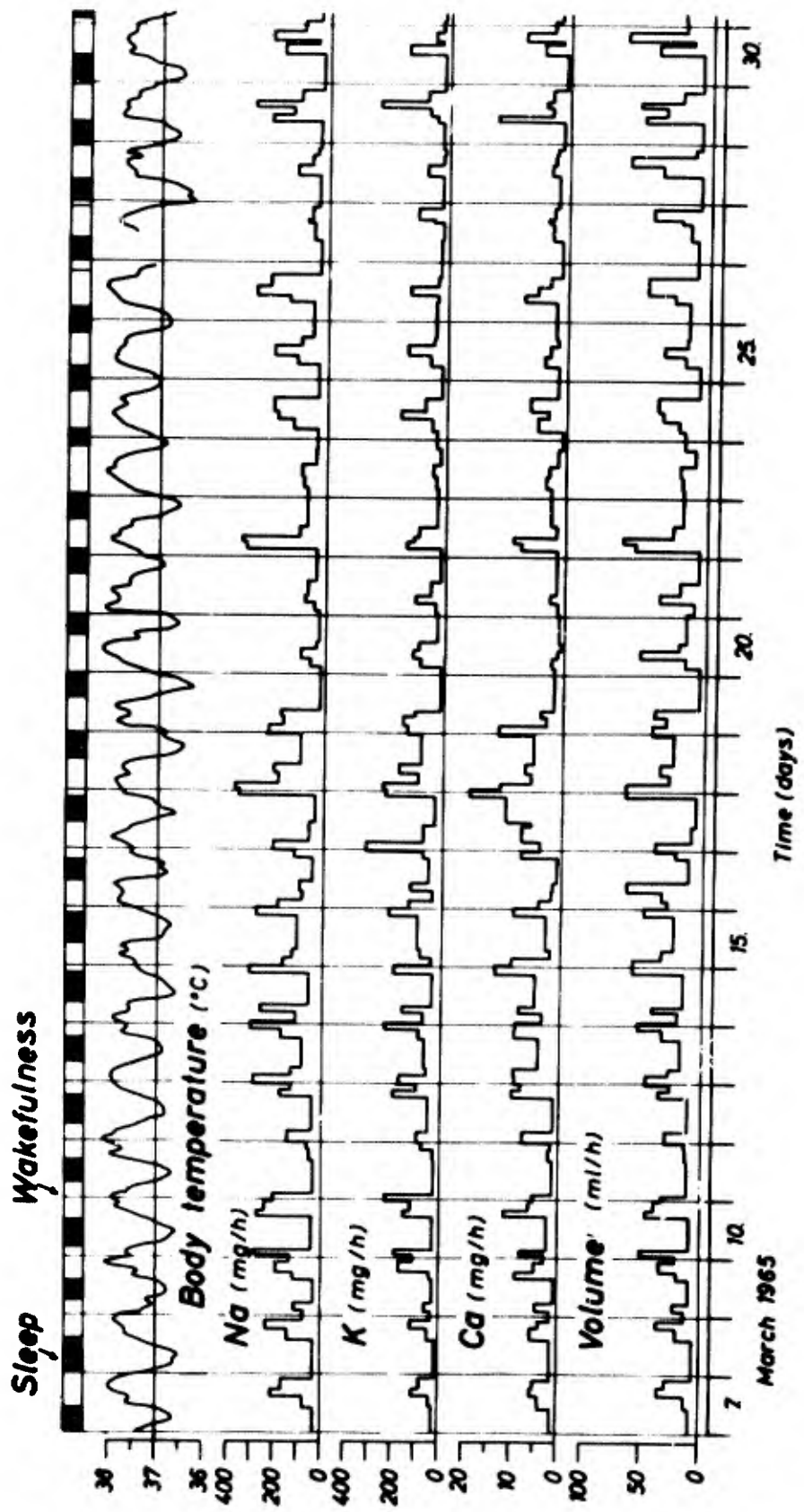

Fig. 1 Free-running circadian rhythms in a human subject, enclosed for 24 days in an underground bunker without time cues. The four curves from below give the urinary excretion of water, calcium, potassium and sodium respectively. Vertical lines drawn at midnight (From 6)

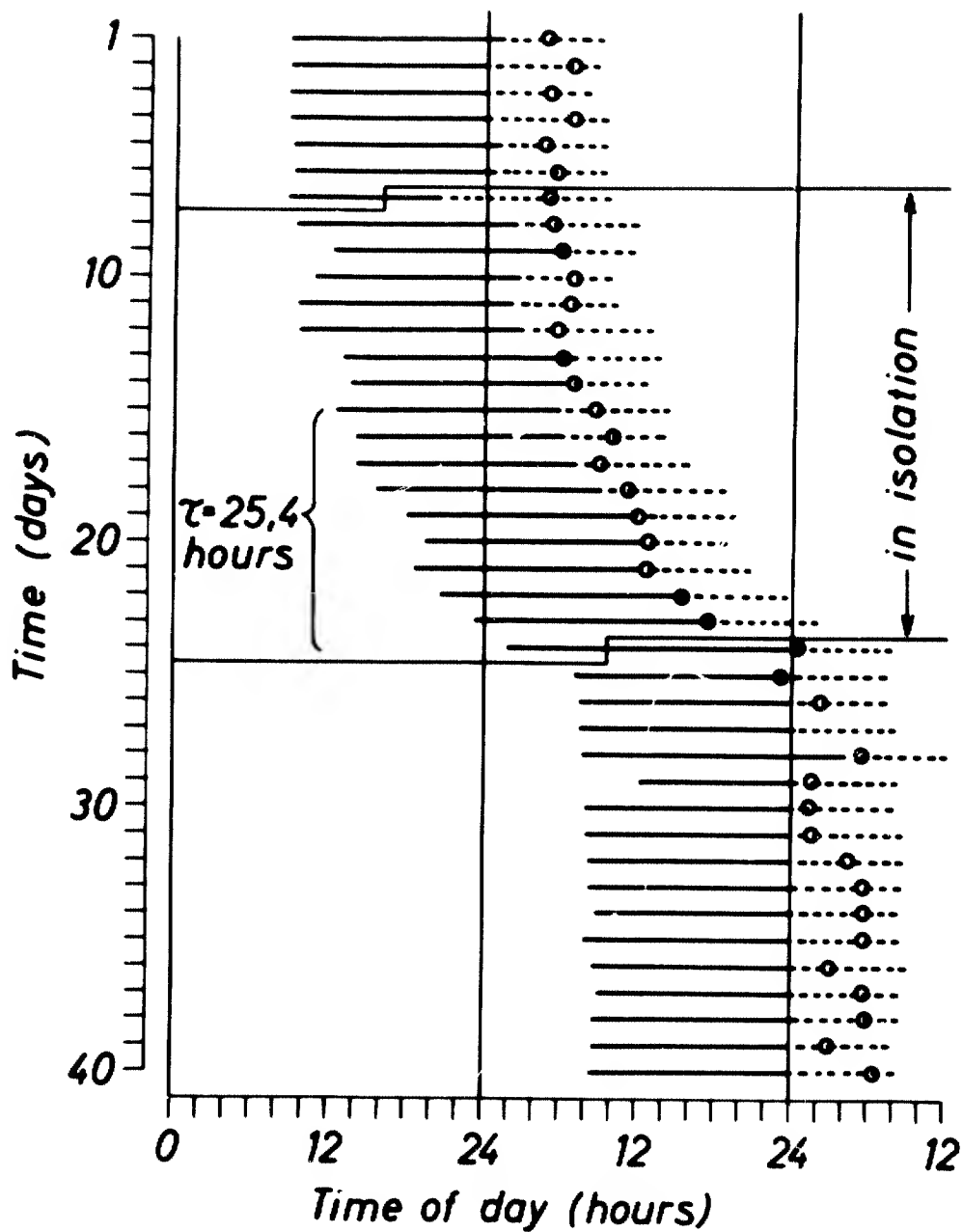

Fig. 2 Circadian rhythms in a subject living, first, under natural conditions, then for 17 days in isolation underground, and finally again under natural conditions. Subsequent days drawn underneath each other. Horizontal continuous lines: wakefulness. Dotted lines: sleep. Open circles: minima of body temperature. τ = circadian period. (From 7)

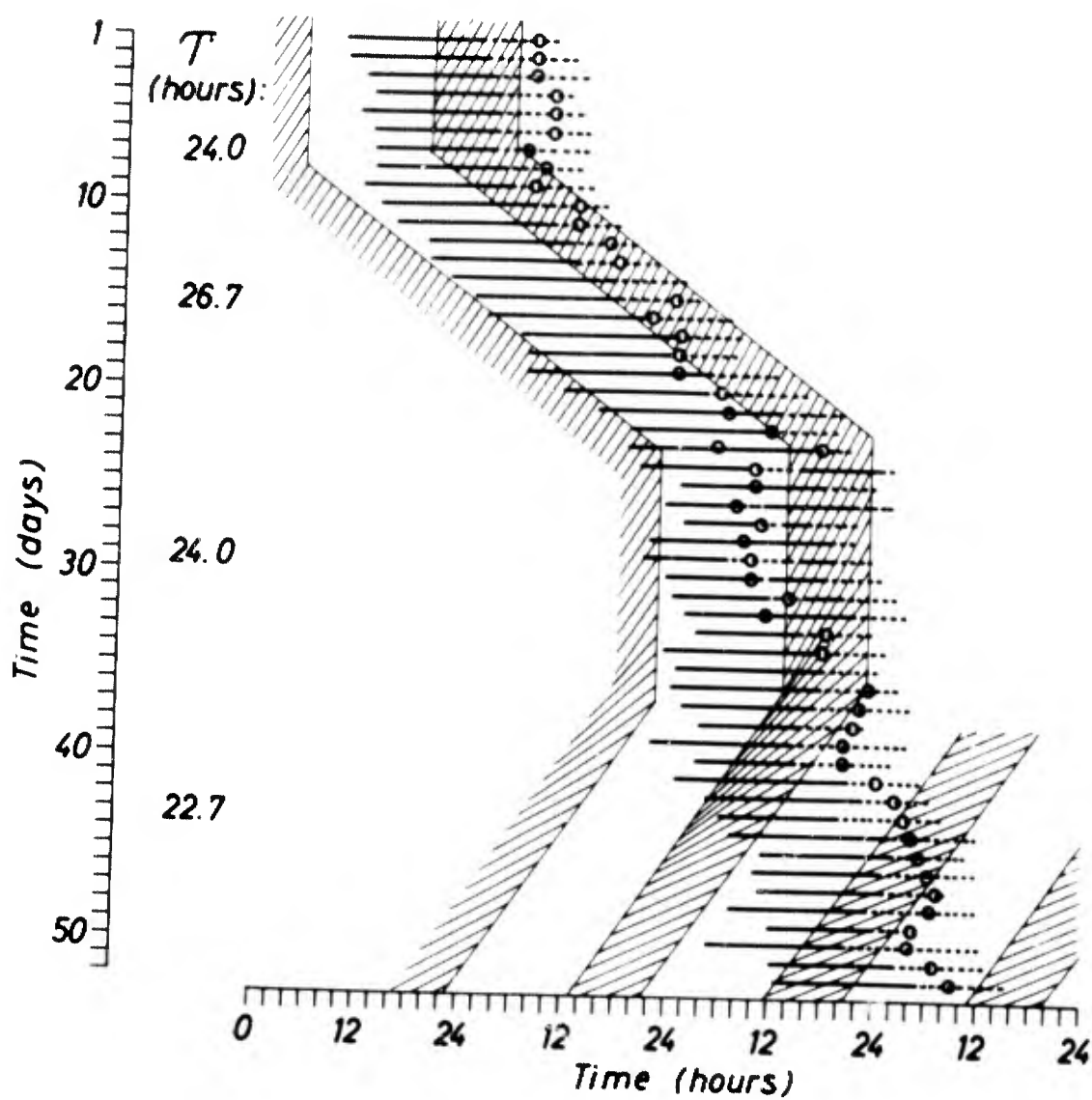

Fig. 3 Circadian rhythms in a subject, kept in isolation and exposed to an artificial light-dark cycle. T = Zeitgeber period. Shaded area: darkness. Horizontal continuous lines: wakefulness. Dotted lines: sleep. Open circles: minima of body temperature (From 10)

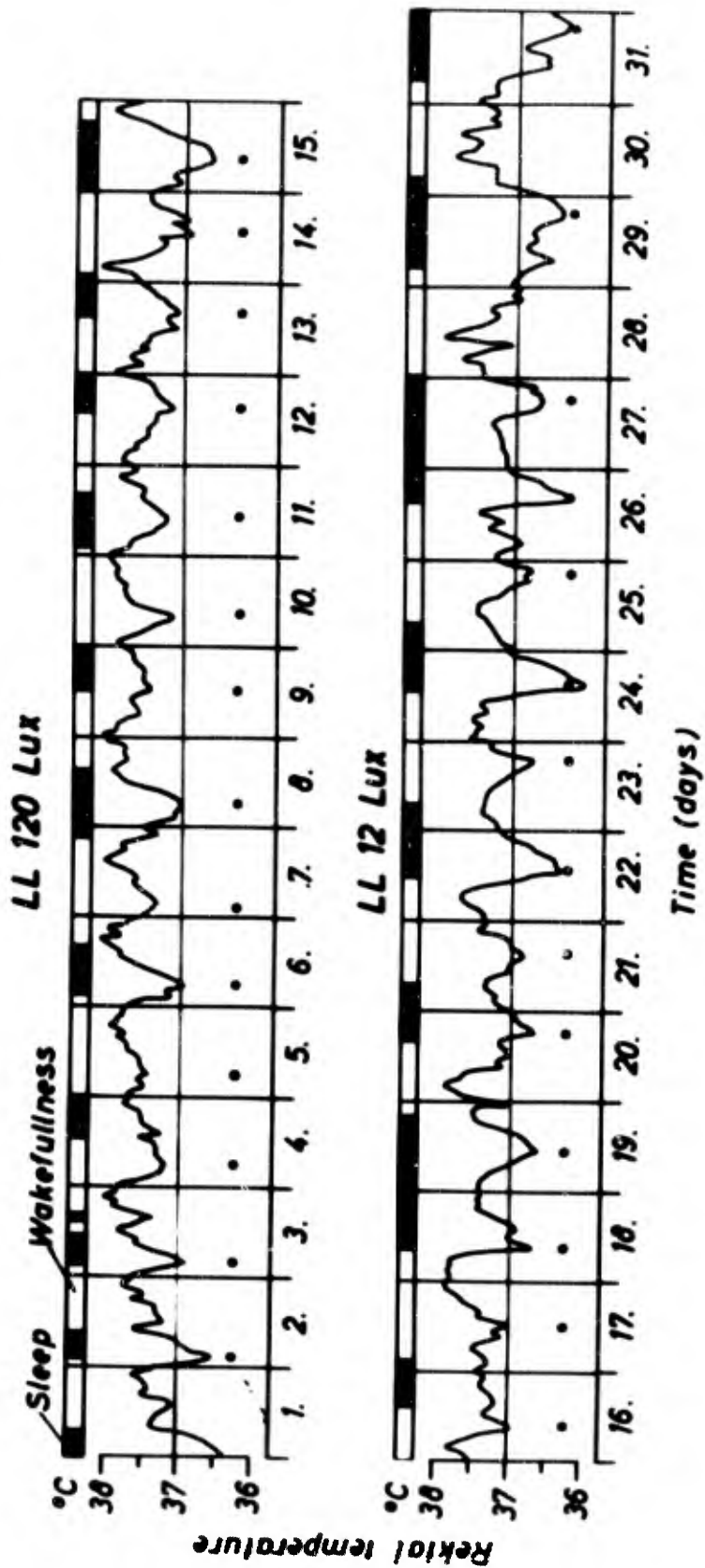

Fig. 4 Circadian rhythms of wakefulness and sleep and of rectal temperature in a subject, enclosed in isolation at two different intensities of constant illumination. Minima of body temperature as used for computations indicated by closed circles. LL: continuous light (From 6)

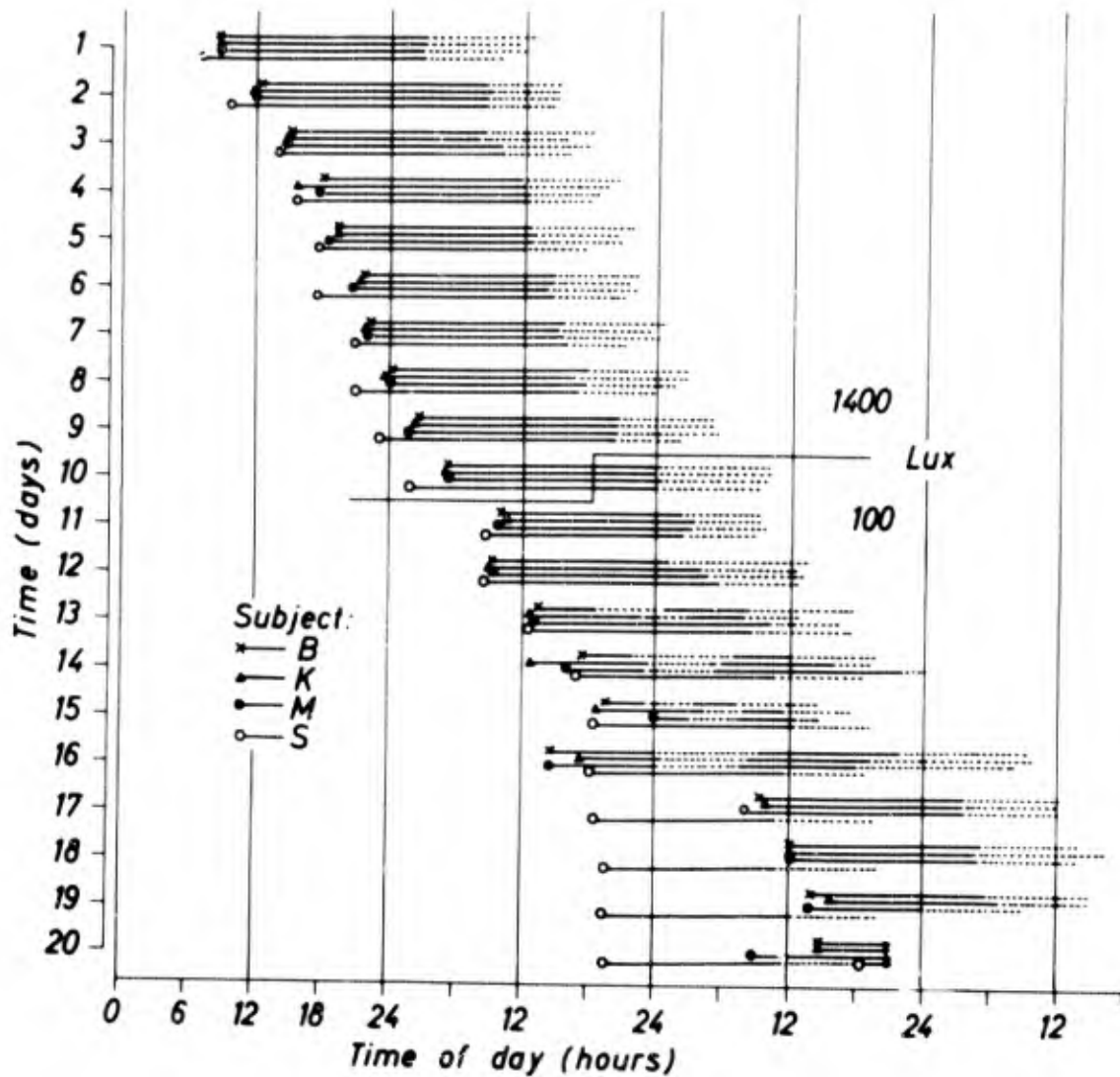

Fig. 5 Circadian rhythms in a group of four subjects, kept underground in isolation at two different intensities of illumination. Horizontal continuous lines: wakefulness. Dotted lines: sleep. (From 17)

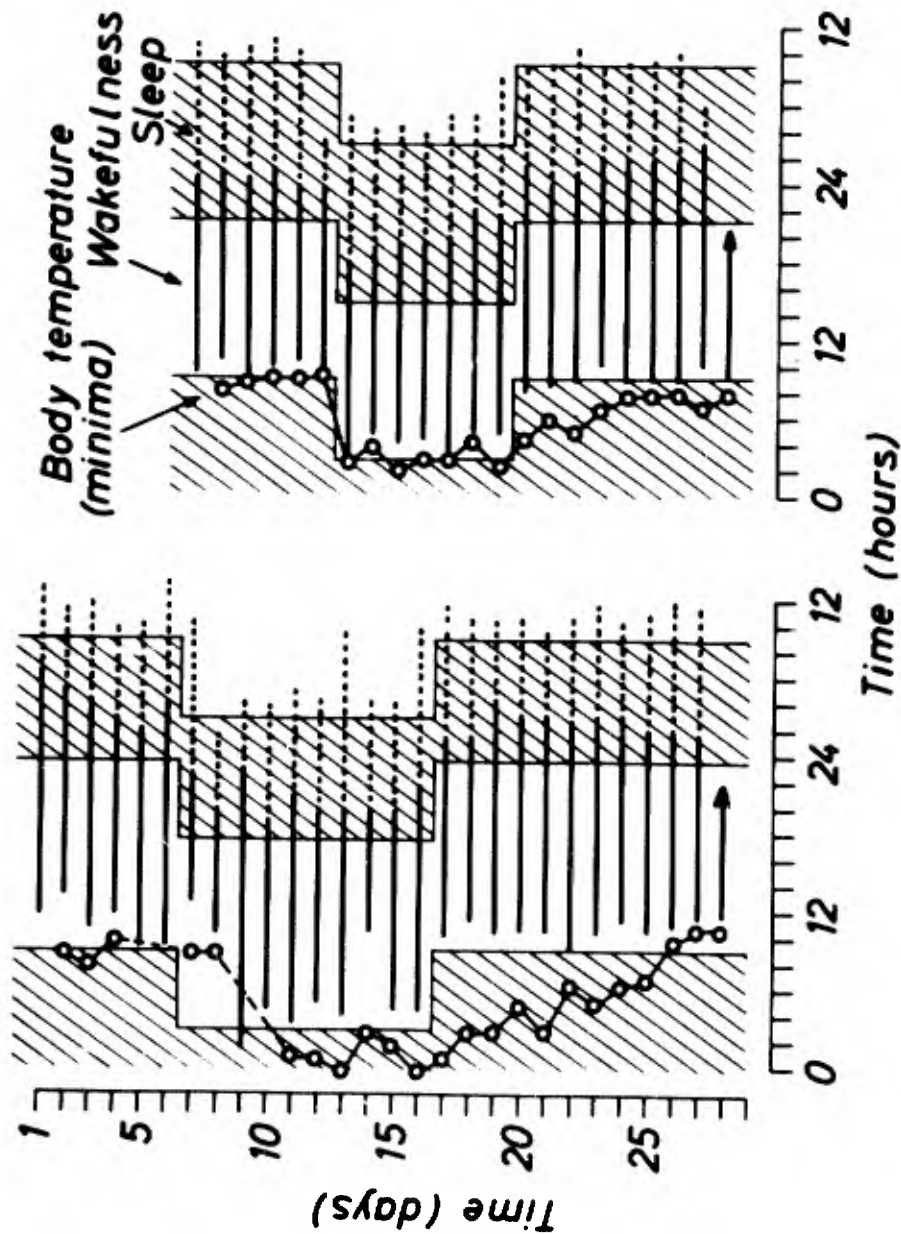

Fig. 6 Effects of phase-shifts on the circadian rhythms in two subjects, kept separately in isolation and exposed to artificial light-dark cycles. Simulation of 'flights' by, first, shortening the light-dark cycle once by 6 hours ('eastward') and, second, by lengthening the light-dark cycle once by 6 hours ('westward'). Shaded area: darkness. Horizontal continuous lines: wakefulness. Dotted lines: sleep. Open circles: minima of body temperature

CIRCADIAN RHYTHMS AND MILITARY MAN

by

Clyde H. Kratochvil, Colonel, USAF, MC

**6571st Aeromedical Research Laboratory
Holloman Air Force Base, New Mexico**

SUMMARY

1. Supersonic transport or even subsonic transport of large numbers of troops will magnify the problem of adjusting to new time zones.
2. It is predicted this may well be a factor of major operational importance.
3. Central to this problem is the issue of altering basic metabolic patterns to provide adequate REM sleep and slow sleep in the correct phase.
4. Present drug therapy is inadequate and may be harmful.
5. The only present solution is repositioning of manpower or pre-adaptation at the home station.
6. Increased investigative effort specifically directed to the alternative of these rhythms is needed.

CIRCADIAN RHYTHMS AND MILITARY MAN

Clyde H. Kratochvil

In spite of a fair amount of discussion in the popular press and a personal awareness by all of us, there has been a paucity of investigations of the problem of the circadian rhythm and military man. The high speed transport of large numbers of troops through multiple time zones is virtually a reality. With the advent of the DC-8-63, soon to be followed by the Boeing 747, the Concorde, and the SST, the problem will be upon us. It is certainly not too early to ask the question regarding the efficiency of man when subjected to this stress. It is also not too early to suggest that this is a research problem deserving of wide attention and vigorous attack. It is the purpose of this paper to review some of the aspects of this problem in the hope of stimulating further investigations.

First, let us look at the physical parameters of these aircraft. Figure 1 illustrates the speed of the aircraft and passenger capacity (1). These data reflect a seating configuration for ordinary commercial service. It should be noted, however, that other sources place the number of passengers in the SST at 350 for a 4,000 mile range. This is twice the capacity and three times the speed of present commercial jet aircraft. It is estimated that the Boeing 747 will go into service in 1969, the Concorde in 1971, and the SST in 1974 (2,3). In essence, this means that no two cities will be more than twelve hours apart. The use of the SST as a military transport is conjectural at the moment. It has been estimated, however, that 400 SST's could move one million combat troops 4,000 miles in ten days (2). What then, if anything, do these data mean for military man and what are the problems we may well encounter?

Thus, we see that with the aid of modern technology it is quite possible to completely reverse the day-night cycles of large numbers of people. Presumably, for our purposes, these people are combat troops from whom the operational commanders will expect immediate, high-level performance. Several important questions immediately come forth: What sort of performance will we expect while the 'adjustment' to the new time schedule is proceeding? Will there be any increase or decrease in susceptibility to various stressors? How long does it take to 'adjust'? Can anything be done to speed up this process?

From the operational point of view, performance decrement is probably the single most important consideration. Hauty and Adams have reported on East-West, West-East, and North-South flights (4, 5, 6, 7). They found a significant performance deficit on only the West-East flight which covered a ten-hour time differential. They point out, though, that the length of the flights (commercial flight schedules) may have obscured some of the effects. Further, they studied only four subjects and their tests may not have been sensitive enough to elicit changes which could be of importance for military men.

Gerritzen has examined the question of the effect of light with respect to renal excretion patterns in a group of KLM subjects flying between Amsterdam and New York, and Bruener, et al, have examined some circulatory parameters on the Frankfurt-New York-Frankfurt flight (8,9). These, however are virtually the only papers that are addressed specifically to our problem. There have been many investigations directed at the problems of fatigue, sleep deprivation, change of work shifts, etc. These are certainly of interest to us, but since they do not involve geographical movement through multiple time zones, they do not answer our question. Fatigue, per se, is well covered by McFarland (10) and more recently by a special report of the Aerospace Medical Association (11).

Since so little has been done to investigate our problem, it may be helpful and instructive to look at what has been accomplished in the hope that this will give us a clue for orienting our research. There is no doubt from past work but what night workers and those who change shifts are more error-prone, have decreased efficiency, and altered feelings of well being (12, 13). What physiological reasons can be adduced for these observations? Franz Halberg, in a paper that should be more widely read, has presented some striking data (14). It should be emphasized here that there are a host of different physiologic functions within the body and that the rhythmicity of these functions is NOT in phase. Indeed, it has been suggested that it may be possible through emotional or traumatic shock to synchronize these rhythms and thus give rise to illness (15). Figures 2 and 3, taken from Halberg, illustrate the point rather dramatically. You will notice from these illustrations the truly fantastic differences in susceptibility to different stressors depending upon the time of exposure. It appears not unlikely that if these rhythms were to be in phase that the organism would suffer some highly vulnerable periods each day.

Clearly, then, it has been shown that there is a change in both efficiency and susceptibility to stress as a function of the time of day. I believe most of us know this intuitively from personal experience. What sort of evidence is there on a more fundamental physiological level, to support these data and the findings from performance investigations? Intimately concerned with this problem of circadian periodicity are the investigations on sleep. One can find excellent reviews of the sleep research literature in Kleitman (16) and in a recent U.S. Public Health Service monograph (17). In a paper such as this, one can only briefly refer to this voluminous body of literature. I will try to bring out several salient points.

We are all concerned with this question of 'adjustment' to new time zones. But just what is meant by this term? Most of us would settle for a return of normal performance efficiency and a feeling of being in phase with the environment. It seems, though that the subject is more complex. Lobban has clearly shown that while the circadian temperature rhythm may quickly adjust to the new time, renal excretion patterns may lag behind. She found that the cyclic patterns for water, sodium, and chloride changed slowly with time but that the patterns for potassium excretion tenaciously clung to the 'old' schedule for as long as six weeks (18). She studied both the effect of the time of the work shift and the exposure to light. Some of her findings are illustrated in Figures 4, 5, and 6. She points out the importance of light as a Zeitgeber, but also emphasizes the importance of the work shift on the excretion patterns. Lindsley, et al have demonstrated the importance of light as a Zeitgeber in the primate (19). The changing of feeding schedules had no effect upon the cyclic behaviour of the monkeys which they studied.

It is also well known that the excretion of 17-hydroxycorticosteroids (17-OHCS) follows a diurnal cycle (20). Flink and Doe have looked into this cycle as affected by a sudden time displacement through air travel (21). They found that after a trip from Minnesota to Japan and then on to Korea that the feeling of wakefulness at night and sleepiness during the day persisted for almost three weeks. The 17-OHCS excretion pattern synchronized with Korean time eleven days after leaving Minnesota. The sodium and potassium excretion patterns also took about eleven days to convert to the new time schedule. They state, 'Mammals can adapt or their rhythm becomes synchronized only slowly when subjected to sudden changes in environmental routine.' (21, page 500). Recently, Weitzman, et al, have attempted to relate the EEG periods of rapid eye movement (REM) sleep to peaks of plasma 17-OHCS. They confirmed the changes of plasma 17-OHCS with the onset of sleep and while they could not postulate a causal relationship between the REM and steroid peaks, they found an impressive correlation between mean REM time and mean level of hormone elevation (22). It is then most probably that steroids are related to sleep, specifically REM sleep and that the change in steroid excretion patterns with a shift in time zone is slow.

Therefore, it is conceivable that at least a partial answer to our problem lies in a further understanding of the mechanisms of sleep and whether or not we can modify these processes. At the core of understanding sleep is the phenomenon of REM sleep. There is now no doubt that REM sleep represents most of the dreaming time in man. It is equally clear that dream deprivation in man has serious consequences (23). Weitzman (22) has noted the apparent inter-relationship of the activity of various neural structures, their impingement upon the hypothalamus and possible subsequent effect upon the pituitary. The relationship of EEG activity, dreams, and variations in plasma steroids forms a rational system. The search for the brain stem mechanism responsible for REM sleep is being led by Michel Jouvet (24). His work on REM sleep deprivation in cats agrees with Dement's work in the human. Jouvet has suggested that REM sleep (or paradoxical sleep, P.S. in his terminology) is dependent upon a neurohumoral process. It should be noted, however, that 'slow' sleep is also of importance. This other phase of sleep has received less attention than the REM phase, but Pegram, in our laboratory, has found behavioural deficits which seem to relate to the lack of slow sleep. The elucidation of the mechanisms of the various types of sleep along with the hope that we can influence them is one of the exciting promises of central nervous system investigations.

What can be said about the tools we now have in our therapeutic armamentarium? Classically we use alcohol or the barbiturates to induce sleep and an amphetamine for awakening. While there is no doubt that we can induce a type of sleep, is it physiological? Barbiturate sleep is easily differentiated from normal sleep through the EEG. Both alcohol and barbiturates decrease the amount of REM sleep (25) and yet we have seen the prime importance of adequate REM sleep. Further, McKenzie and Elliot have been able to demonstrate a degradation of performance following 200 mg. of oral secobarbital (26). The drug was given ten hours before testing began and its effect was still apparent 22 hours later. The addition of d-amphetamine at the beginning of the test did not improve performance. On a similar schedule and test, Hartman and McKenzie could not show an effect from 100 mg. secobarbital, but confirmed the decrement found with 200 mg. (27). Hyden, using the elegant single cell analytical techniques developed in his laboratory, has shown a marked difference in the metabolism of the neurons and glia in the caudal reticular formation during sleep (28). Strangely, the succinoxidase activity is highest in the neurons in sleep and this reverses during waking. However, when sleep is induced with pentobarbital, the succinoxidase level is

lower than in physiological sleep and inverse changes in the neuron-glia unit are not found (29). It is apparent that we do not presently have the tools to induce normal, physiological sleep. Indeed, we lack basic information as to the importance of these manifestations of the biologic clock. In terms of the functional capacity of a fighting man, does it matter, for instance, whether or not potassium excretion is in the correct phase? I should think so, for it probably reflects other metabolic derangements - but the data necessary to make these judgements are lacking.

The story that is emerging here tells us that we must sleep, more importantly we must dream and yet we do not know how to alter this very fundamental mechanism. Indeed, as Cloudsley-Thompson has remarked, 'The remarkable persistence of normal temperature and urinary rhythms in night workers in civilized communities has long been recognized, (30). Altman reinforces this with two statements: 'They are resistant to modification by chemical interference or changes in temperature over a wide range', and 'The physiologic processes responsible for these rhythms in general and the circadian rhythm in particular are not known' (31). Many other authors and examples could be quoted, but those above should suffice.

Given the existence of these phenomena and the very real possibility that they will be of marked operational importance, what solutions are available? Several authors, among them Strughold, have proposed two solutions that are now possible - either travel to the new time zone well in advance of having to perform at peak efficiency or pre-adapt at the home station (32). Whether these solutions are operationally feasible is a separate problem. The use of drugs has also been proposed, but as yet we do not have any which function in a physiologic manner.

REFERENCES

1. Stuart M. Levin, *Space/Aeronaut.* 48 No.1, July, p 78.
2. John Mecklin, *Fortune*, 75 No.2 Feb 1967, p 113, 114, 227.
3. J.S. Butz, Jr., *Air Force/Space Digest*, 50 No.2, Feb 1967, p 38.
4. G.T. Hauty and Adams, T., *Aerospace Med.* 37 No.7 July 1966, pp 668-674.
5. G.T. Hauty and Adams, T., *Aerospace Med.* 37 No.10, Oct 1966, pp 1027-1032.
6. G.T. Hauty and Adams, T., *Aerospace Med.* 37 No.12, Dec 1966, pp 1257-1262.
7. G.T. Hauty and Adams, T.: *Circadian Clocks*, Amsterdam, North Holland Publishing Co., 1965, Ed. J. Aschoff, pp 413-425.
8. F. Gerritzen, *Aerospace Med.* 37 No.1, Jan 1966, pp 66-70.
9. H. Bruener, Klein, K.E., Ruff, S. and Wegmann, H.M., *Aerospace Med.* 36 No.6, June 1965, pp 552-553.
10. R.A. McFarland: *Human Factors in Air Transportation*, 1st Ed., New York, McGraw-Hill Book Co., 1953, Chapter 7.
11. O.B. Schreuder, *Aerospace Med.* 37 No.4, Apr 1966, Section II.
12. R.C. Browne, *Occup. Psychol.* 23: 121, 1949.
13. B. Bjeiner, et al., *Br. J. ind. Med.* 12: 103, 1955.
14. F. Halberg: *Cold Spring Harbor Symposia On Quantitative Biology*, Vol 25, Biological Clocks, Baltimore, Waverly Press, Inc., 1961, pp 289-310.
15. C.P. Richter: *Biological Clocks in Medicine and Psychiatry*. Springfield, Charles C. Thomas, 1965.
16. N. Kleitman: *Sleep and Wakefulness*, Rev. ed., Chicago, University of Chicago Press, 1963.
17. G.G. Luce: *Current Research on Sleep and Dreams*, Washington, U.S. Government Printing Office, PHS Publication No.1389, 1965.
18. M.C. Lobban: *Circadian Clocks*, Amsterdam, North Holland Publishing Co., 1965, Ed. J. Aschoff, pp 219-227.
19. D.F. Lindsley, Wendt, R.H. Fugett, R., Lindsley, D.B. and Adey, W.K. J. comp. *physiol. Psychol.* 55 No.4, 1962, pp 633-640.
20. F.H. Tyler, Migeon, D., Florentin, A.A. and Samuels, L.T. J. *clin Endocr. Metab.* 14 No.7, July 1954, p 774.

21. E.B. Flink and Doe, R.P. Proc. Soc. exp. Biol. Med. 100 No.3, March 1959, pp 498-501.
22. E.D. Weitzman, Schaumburg, H. and Fishbein, W. J. Clin. Endocr. Metab. 26 No.2, Feb 1966, pp 121-127.
23. W. Dement, Science (Wash, D.C.) 131 No.3415, 10 June 1960, pp 1705-1707.
24. M. Jouvet, Proc. XXIII Int. Congr. physiol. Sci. Tokyo, Sept 1965, pp 344-353.
25. G.G. Luce: Current Research on Sleep and Dreams, Washington, U.S. Government Printing Office, PHS Publication No.1389. 1965, pp 43-45.
26. R.E. McKenzie and Elliot. L.L. Aerospace Med. 36 No.8, Aug 1965, pp 774-779.
27. B.O. Hartman and McKenzie, R.E. Aerospace Med. 37 No.11, Nov 1966, pp 1121-1124.
28. H. Hyden and Lange, P.W. Science (Wash, D.C.) 149 No.3684, 6 Aug 1965, pp 654-656.
29. A. Hamberger, Hyden, H. and Lange, P.W. Science (Wash, D.C.) 151 No.3716, 18 Mar 1966, pp 1394-1395.
30. J.L. Cloudsley-Thompson: Rhythmic Activity in Animal Physiology and Behavior. New York, Academic Press, 1961, p 147.
31. J. Altman: Organic Foundations of Animal Behaviour. New York, Holt, Rinehart and Winston, Inc., 1966, pp 419-421.
32. H. Strughold: Circadian Cycles. Lecture given at the School of Aerospace Medicine, USAF, Brooks Air Force Base, Texas, 11 Aug 1967.

	CRUISE		PASSENGERS	
	MACH NO.	VELOCITY M.P.H.	IST. CLASS	COACH
SST	2.7	1780	28	252
CONCORDE	2.2	1450	12	112
747	0.9	590	33	351
DC-8-63	0.82	540	20	204
707-3208	0.82	540	14	147

Fig.1 Velocity and passenger capacity (commercial) of some transport aircraft.

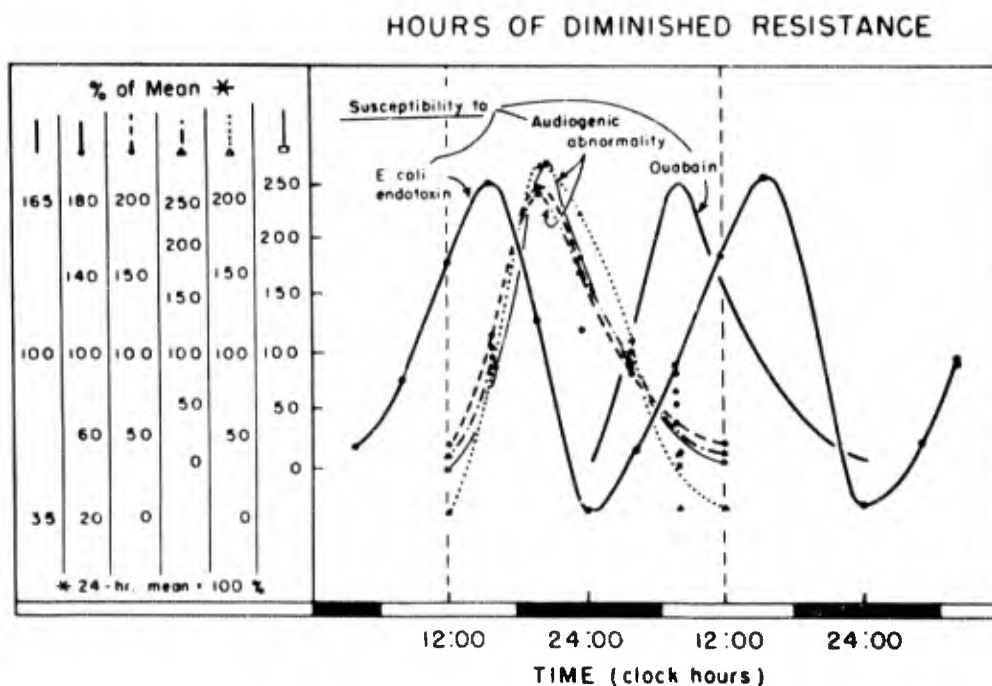
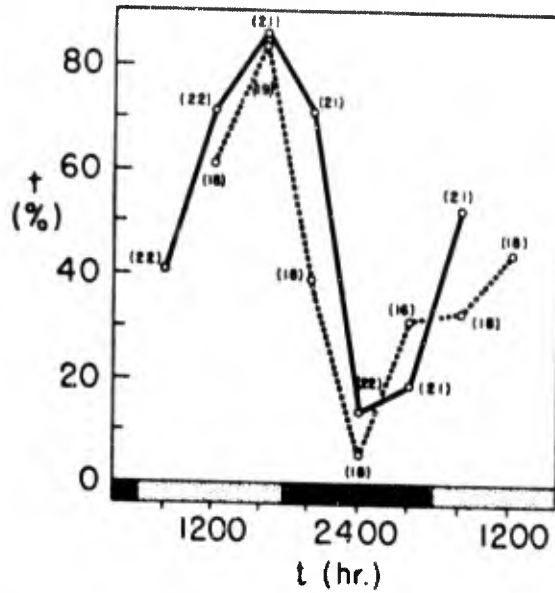

Fig.2 Circadian susceptibility rhythms. From Halberg (14).



Ordinate { % death of group of standardized mature C mice
 †(%) { from E. coli lipopolysaccharide (Difco, 100 μg./20 gm., i.p.).
 Abscissa { times of injection, in 2 experiments (injections begun at 2
 t(hr.) { different time points, during daily light period).
 N of mice/group in parentheses.

Fig.3 Circadian susceptibility to intraperitoneal Escherichia coli endotoxin..
 From Halberg (14).

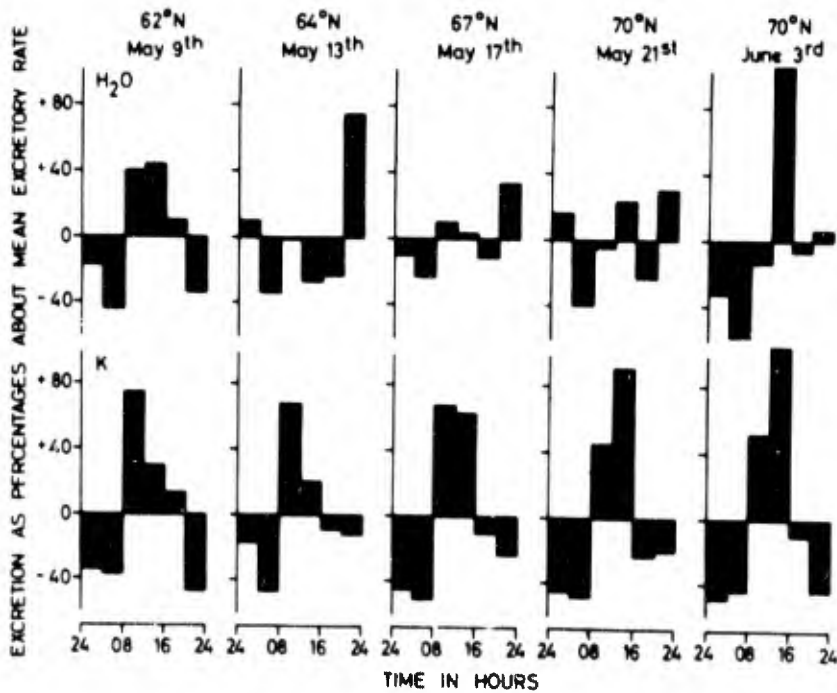

Fig.4 Excretion of water and potassium by subjects during an Arctic summer journey.
 N=3, rates plotted as percentage of mean. From Lobban (18).

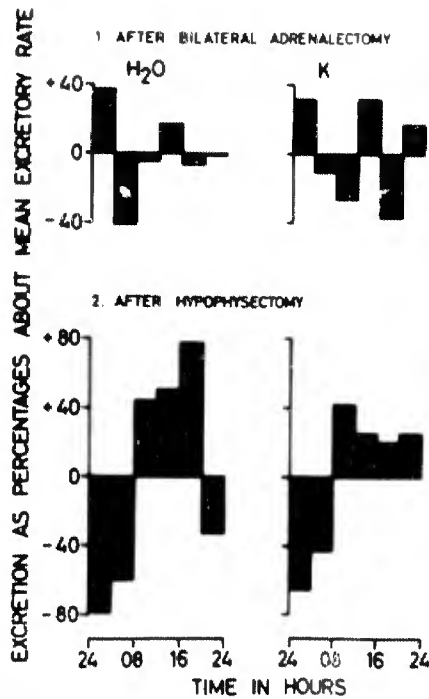

Fig. 5 Excretion of water and potassium by female patient after adrenalectomy followed by hypophysectomy. Rates plotted as percentage of mean. From Lobban (18).

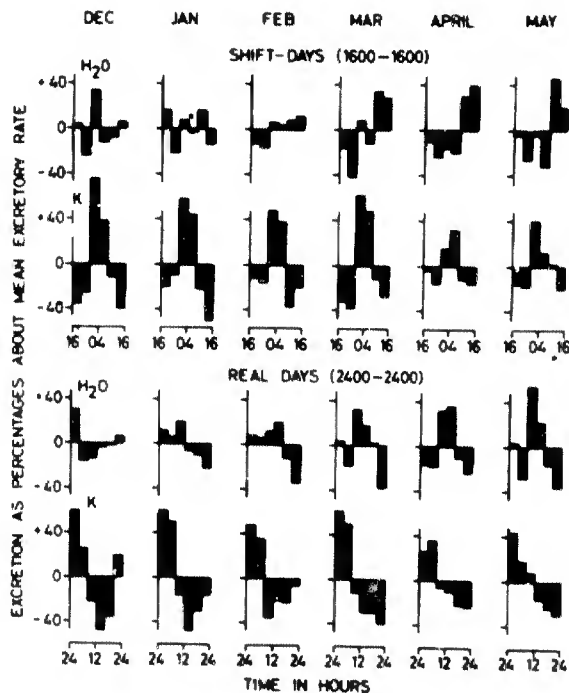

Fig. 6 Excretion of water and potassium by mine workers on nightshift in an Arctic community. Rates plotted as percentage of mean. From Lobban (18).

BLANK PAGE

**THE USE OF PERIOD ANALYSIS TO EVALUATE
HUMAN PHYSIOLOGICAL AND PSYCHOMOTOR PERFORMANCE**

by

Michael McCally, M.D.

**6570th Aerospace Medical Research Laboratories,
Wright-Patterson Air Force Base, Ohio**

SUMMARY

In the field of environmental medicine, it has recently become necessary to evaluate human physiological and performance status over prolonged periods (minutes to months) during low levels of sustained environmental stress (confinement, heat, vibration, acceleration, etc.) rather than during the more conventional dynamic transients of these stresses. It has been amply demonstrated by Halberg and others that the activity of a given physiological or performance variable is not random between statistically determined normal limits but rather is cyclic or rhythmic with periods characteristic of the organism and the environment. This is the spectral or homeokinetic view of physiologic function, the temporal complement to homeostasis. Known periods of physiologic function have recently been mapped and modelled by Iberall. The period, amplitude and phase characteristics of physiologic and performance variables are the obviously necessary descriptors of human status during long term low intensity environmental stress. Such analysis is currently being applied in the areas of medical diagnosis and therapy and biological control theory. Recent developments in techniques of time series analysis and their mechanization by computer have made spectral analysis available to the environmental physiologist. This paper will present the application of a so-called least-squares spectrum to a number of time series collected in this laboratory. Urine was collected from four subjects during a 36 day space cabin simulator study. A normal 24 hour day was used and subjects ate diets of known quantity and composition. Circadian (24 hour), 3½ day, 7 day and 29 day periods were observed in urine flow. Other time series (heart rate, respiration rate, ventilation, and O₂ consumption) have been analyzed over shorter 2-24 hour periods to demonstrate ultradian (less 24 hour) periods. It is apparent that detailed mapping of the spectra of a variety of physiological and performance variables over a wide bandwidth of period, perhaps from one second to one month, at rest and during various levels of environmental stress will ultimately be required.

THE USE OF PERIOD ANALYSIS TO EVALUATE
HUMAN PHYSIOLOGICAL AND PSYCHOMOTOR PERFORMANCE

Michael McCally, M.D.

INTRODUCTION

The study of the activity of human physiological systems can be approached in two general ways: the homeostatic and homeokinetic. In the former approximation of physiologic functions, one establishes certain upper and lower limits in order to evaluate gross deviations from the normal level. The normal level is usually represented as a mean value of linear trend. The limits are drawn as confidence intervals in classic statistical terms.

Figure 1, taken from Halberg, is a schematic illustration of the difference between the homeostatic and the homeokinetic or spectral view (1). The vertical axis represents physiological variation in the excretion of an adrenal corticosteroid. The homeostatic approach implies that changes within this normal range are random with respect to time. Values that exceed statistical limits are then abnormal. In the case of this example, an increase above the normal range represents Cushing's syndrome and a decrease below the normal range represents Addison's disease. The mechanisms by which organisms strive to maintain the mean value or normal range have been termed "homeostatic". Homeostasis has been the underlying concept of mammalian physiology for more than a hundred years. The homeokinetic or spectral approach is based on the view that an organism's physiological behavior is rhythmic or non-randomly organized with respect to time. The periodic organization of physiologic systems has been obvious to biologists for centuries. Periodicities spanning the spectrum of the one cycle per second period of resting heart rate to annual or seasonal variations in thermal regulatory mechanisms are well known. These early clues of temporal organization are suggested in the middle panel of Figure 1 which points out daily, weekly and seasonal variations. The circadian or twenty-four hour periodic organization of biologic systems has been appreciated for many years. Workers such as Ashoff, Halberg, Brown, Pittendrigh and many many others have made lifetime studies of the significance and mechanisms of twenty-four hour rhythms. In recent years, with the availability of appropriate tools, in particular, computer programs, for handling the voluminous data involved in time series analysis, studies of the periodic behavior of physiologic systems have been extended both into the lower frequency periods of weeks, months and years and more recently into the higher frequency periods of seconds, minutes and hours. The panel to the right suggests that the organization of physiological variations with respect to time is orderly. The specific quantities descriptive of any periodic or rhythmic event, namely frequency, amplitude and phase are then the descriptors of physiological function.

Halberg, who coined the phrase "circadian" for periods of about one day, has extended his nomenclature to include a broader spectrum of physiologic periods².

Circannual or seasonal periodicity in human physiologic function has been described in basal metabolism, plasma CO₂ tension, body temperature, heart rate, hemoglobin levels as well as in serum calcium and phosphate. Seasonal variations have been described in the incidence of psychosis, suicide and crime.

Circatrigintin periods are obvious in the female endocrine reproductive cycle. Halberg, Engelli, Hamburger and Hillman have recently described near 30 day periods in 17 keto-steroid excretion and urine volume of a healthy human male². In addition a 17-20 day or circavigintin component and a seven day or circaseptan component were present. Circadian rhythms with one cycle in about 24 hours are perhaps the best known and best studied of biologic rhythms and numerous excellent reviews are available^{1, 3, 4}. The organization and interrelationships of these periods as well as the role of exogenous "zeitgebers" or geophysical clues versus that of endogenous synchronizers or biologic clocks is at present not clear. In this table Halberg has also suggested the term "infradian" for periods greater than daily and less than weekly and "ultradian" for all those periods of less than 24 hours. In this paper I would like to review briefly the methods that are now available for the assessment of physiologic infradian and ultradian rhythms and present preliminary results of recent studies employing these techniques, including examples of 3, 7 and 30 day rhythms in urine volume and a spectrum of ultradian rhythms in heart rate, pulmonary ventilation and oxygen consumption.

METHODOLOGY

The data with which we are concerned consist of repeated measurement or observations made over some finite time interval. This constitutes a "time series". To describe this data, we may take mean values at given points or ranges in time. Differences in mean values as a function of time may then be considered and tested by classical biostatistical procedures. However, more complete information is obtained by analyzing the frequency structure of the time series. To correctly define a time varying response, we must first decompose the time series into its component periods and measure the changes in units of period, amplitude and phase.

A first step toward this goal is often a plot of the original data made as a function of time. Such plots will often reveal near rhythms or rhythms by inspection. This figure presents the urine volume in ml/void for 2 subjects for 36 days under constant conditions during a chamber confinement test. The horizontal lines indicate mean values (\bar{X}) for the entire 36 day period of 250 and 610 ml respectively.

In the analysis of biologic time series, curve fitting by hand is still extremely useful. The following data were established by this method. These data are nominal periods in heart rate in a seated resting subject studied for four hours was obtained by Iberall. Consider the first column only. The output from an automatic electronic heart rate counter (cardiotachometer) was a spike (amplitude) equivalent to the time between successive heart beats, the so-called instantaneous heart rate. The apex of each spike was connected by a pencil line for the entire length of the record, demonstrating a high frequency oscillation. The total number of oscillations counted over

the time of the experiment divided by the total number of seconds gave the shortest period cycle of 0.75 secs/cycle. Then the midpoints of each line were connected and the same procedure repeated to define the next period of 3.4 mins/cycle. This continued until no further filtering was possible. Low frequency long periods and linear trend were identified by hand fitting with a thick shaded pencil. The results of such a manual analysis for a single subject are presented in Figure 3 and include demonstration of 0.75 second, 3.4, 8.8 and 35 minute periods. We will discuss these findings further below.

In the study of biologic rhythms, which are more or less regular variations in level, we must evaluate the reproducibility of these changes in terms of measurable quantities such as cycle length or period (or frequency, the reciprocal of period), the amplitude of each period contributing to the data and the phase relationships between a given periodicity and some reference standard.

Mathematical techniques for time series spectral analysis have been available for many years and include the periodogram, the autocorrelation function, the Fourier transform of the autocorrelation or power spectral density, as well as moving averages, digital filtering and related techniques. These methods have been applied to time series analysis of economic and business cycles and geophysical cycles; their applicability to biologic data has been limited. In particular these techniques require data occurring or sampled at regular intervals. Humans do not breathe, void, pump blood, or perform at clockwork intervals. Indeed it is well known that to impose regular sampling intervals upon human subjects is to impose this same period and perhaps its harmonics on the observed responses.

Recently Halberg at the University of Minnesota and Rummel at the National Aeronautics and Space Administration Manned Spacecraft Center have developed the technique of the so-called "least squares spectrum"². This is a computational procedure prepared as a digital computer program which provides a simple and reliable method to: (1) define significant periods in time series, particularly in data collected at unequal intervals or with gaps and (2) to quantify each period as to its amplitude and phase in an objective and reproducible fashion.

In the least squares spectrum, functions of the form given in Figure 5 are fitted to the data for a number of trial periods by methods of the least squares regression. That is, the sum of squares of differences between the given harmonic function or trial period and the data is minimized. For each trial period, τ , C_0 , the constant term or level of the function, C , the amplitude, and ϕ , phase are computed and displayed with a standard error of the estimate of each. Trial periods are chosen on the basis of prior knowledge or from inspection of the raw time series. That is, data with obvious or suspected circadian components are examined with trial periods or "windows" of from 20 to 30 hours. When the periods are not obvious or are unknown, scanning is done across broad spectral windows. Considerations of sampling variability and the problems of sampling unequal data or series with missing observations have been discussed in detail elsewhere².

This potent analytic technique has a number of underlying assumptions and is easily misused. Two obvious problems present themselves to any user of such a technique. First, is a period demonstrated by this type of analysis actually present in the data or did it appear in the process of computation? Secondly, if an observed period is

mathematically valid what is its biological or physiologic meaning? With regard to the former, the problem resides in the assumption of stationarity in the time series. If the time series is not stationary and most biologic time series surely are not, it is possible to generate periods that are not present. The requirement of stationarity is generally avoided by examining small blocks of data in overlapping samples; but the assumption must be kept in mind. Secondly, problems with regard to aliasing or the appearance of harmonics of higher frequencies present in the data must be considered. Additional mathematical procedures are available to answer this question and the possibility must be considered, particularly when periods of unknown physiological significance are demonstrated. A number of statistical procedures are available for testing the hypothesis that the period fitted does indeed characterize the data analyzed. Halberg has discussed the techniques of the error ellipse². Other techniques are available. With regard to the latter problem, the physiologic significance or reality of an observed periodicity is ultimately established only by identifying the physiological mechanism responsible for the periodicity and interfering with its activity. For example, in 1938 Burton demonstrated a 50 to 60 second period in digital or finger pulse amplitude and related this periodicity to mechanisms of peripheral thermoregulation. He was able to demonstrate that the period of digital pulse amplitude related directly to the temperature of the extremity⁵.

CIRCADIAN AND INTRADIAN PERIODICITIES IN URINE FLOW

Figure 3 presents the urine volume in cc's per void for each of two subjects during a 36 day chamber confinement. Subjects voided ad lib and not at equal intervals. Conditions of diet, activity, work-rest periods and sleep were constant throughout the exposure. An irregular 24 hour period is apparent in the raw data of both subjects. A single near monthly cycle is also suggested.

This figure demonstrates the application of the least squares spectrum to the raw data of the two subjects of figure 3 over a window from 4 to 104 hours. The squares (lower lines) represent the relative amplitudes of each of the trial periods within this window and solid circles (upper lines) the standard error of the period. This broad spectrum suggests the presence of 24 hour and 74-84 hour periods in this data.

This slide summarizes nominal periods in urine flow in confined normal subjects as suggested by these techniques. The existence of these periods in the data is suggested by the literature, the raw data, the broad window least squares spectrum and is confirmed by examining the data with narrow spectral windows in each of these ranges. A 3½ day periodicity in urine volume is especially interesting. Such a period had been previously noted by Halberg in the urine volumes of a single subject collected over some 16 years as well as in body weight data collected by Iberall. The mechanism of this periodicity is entirely unknown although the response to administered thyroid hormone has a similar time course and the involvement of this endocrine system has been suggested. The demonstration of a 3½ day periodicity in urine volume suggests that antidiuretic hormone and aldosterone activity and intrinsic renal mechanisms should be investigated in this time domain. The 7 day periodicity was unexpected as the chamber environment was constant for the duration of the run without normal weekend social organization. Halberg has demonstrated a 7 day period in urine volume in an individual in a normal 5 to 6 day work week. He raised the intriguing question of whether the physiologic 7 day period phylogenetically preceded or was induced by

the societal seven day week. The present data suggests that for the duration of this study the 7 day period persisted in the absence of the normal 7 day social-week clues. The observation of a 29 day cycle in volume of urine excretion by normal male subjects also confirms Halberg's observations².

ULTRADIAN PERIODS

A literature survey of the time varying behavior of human physiologic subsystems discloses a large number of autonomous oscillators continuously operating^{6, 7}. Each physiologic subsystem oscillates with periods characteristic of that system. A partial frequency spectrum in man will include primary neurofrequencies in the range of 5 to 50 c/s, a muscle motor frequency of about 10 c/s, heart beat at about 1 c/s, respiratory period of about 1 cycle in four seconds and circadian rhythms of nearly all functions of one cycle per day. To these may be added cycles demonstrated in recent years in ventilation rate, local skin temperature, and metabolism with periods of 1 to 2 minutes, 6 to 7 minutes, 10 minutes, 30 minutes, 2½ to 3 hours. It has become apparent, as these periodicities in physiologic operation are identified, that the many oscillators in a biologic system are not incidental characteristics but represent working components of the system. A study of the ultradian rhythms including a spectral mapping of physiologic function in the 1 second to 20 hour per cycle domain is just beginning and promises to be a stimulating new approach to the study of physiologic regulation. I would like to mention some recent observations on ultradian rhythms in heart rate, ventilation and oxygen consumption.

HEART RATE

Figure 4 is presented again to demonstrate results from four hours continuous recording of beat to beat heart rate in a quiet seated male subject. The mean resting heart rate for the period was 72 beats per minute with a range of 20 beats per minute and standard deviation of the mean of 7 beats per minute. When reduced by hand the following nominal periods are present: the 0.75 second per cycle period is of course the heart rate cycle. The 3.4 second per cycle period is respiration. The respiratory cycle by its effect on intrathoracic hemodynamics produces cyclic changes in cardiac output, arterial pressure and reflexly, heart rate, that all occur with the same period as the respiratory cycle and have been classically described. Of more recent interest is the 8 to 12 second per cycle period which has been noted here in quiescent and exercising heart rate. Clynes has noted this period in the heart rate of a large number of normal resting subjects of both sexes and various ages and attests to its reproducibility⁹. He postulates a biphasic reflex change in heart rate produced by inspiratory action and lasting about 12 seconds. Namely, on active inspiration, heart rate initially increases then decreases considerably and finally increases again returning to approximately its initial rate. Clynes states that the initiating cause of this respiratory heart rate reflex is stretch receptors in the thorax and that the 12 second cycle period may well represent the time response of the arterial baroreceptors. This cycle is not seen in all subjects at all times. The 3 to 4 minute, 7 to 12 minute and 30 to 40 minute cycles have been described by Iberall⁷ and confirmed by us. Their physiologic significance remains unestablished.

VENTILATION AND OXYGEN CONSUMPTION

Figure 8 presents the oxygen consumption in ml/minute of two seated resting subjects over two hours sampled at minute intervals. The periodic, non-random, nature of resting oxygen consumption is visible to the naked eye. Manual reduction and least squares spectral analysis by ourselves and autocorrelation analysis of similar data by Goodman *et al* have been performed⁸.

Figure 9 presents a least squares spectrum of the oxygen consumption data of the previous figure for two subjects over a broad window of from 5 to 105 minutes. The connected squares are the relative amplitudes of the fitted periods and the circles are the standard error of that period. This spectrum suggests the presence of periods of 15-20, 35-40 and 90-105 minutes in oxygen consumption in resting subjects.

The data from Figure 10 is taken from Goodman *et al* and presents the nominal periods of major components of resting respiratory gas exchange. In respiratory quotient and oxygen consumption cycles of two, five, ten and fifteen minutes, one and three hours are seen. The amplitude of the individual oscillatory components is between two and four per cent of the mean summing to give a total variation in the course of a four hour recording of plus and minus 10 to 20 per cent of the mean. The significance of these periodicities is as yet unknown and awaits further experimental study of respiratory regulation. However, two points can be made from these data that apply to all of the material being presented. First, any clinical tests or control data based on the assumption that ventilation or heart rate is constant over a period of time, as in a basal metabolic rate, must be viewed with care. Secondly, the physiologist must be cautious to insure that an apparent ventilatory or heart rate response to a given stimulus or environmental change is indeed a response to the stimulus and not merely a reflection of normal oscillatory behavior of the monitored variable.

CONCLUSIONS

These data have been presented not as definitive experiments to demonstrate effects of environmental change but rather as a demonstration of a new tool and a new point of view for the environmental physiologist; and to suggest new directions for research. The following questions may profitably be raised: (1) What are the characteristic periodicities of each of the major physiologic subsystems and how do they vary with time of day, from individual to individual, and what effect do environmental factors play? (2) Can each periodicity be related to a specific physiologic regulation? (3) Might online data handling techniques be developed to enable the investigator to monitor heart rate or respiratory periods directly and might such variables be more sensitive indicators of physiologic states in response to environmental stress than instantaneous or mean values? (4) One day, three and a half day, seven day, 28 day periods have been identified in urine volume. Might the phase and amplitudes of such periodicities not be the most sensitive variables to monitor in the evaluation of human subjects during long term confinement and low level environmental stress as in prolonged space flight and extended aircrew missions? The information needed to answer such questions includes: (1) detailed mapping of the spectrum of a variety of physiological and performance variables over a wide band, perhaps from one second to one month, at rest and during various levels of environmental stress, (2) the development of

meaningful statistical procedures for defining confidence limits for changes in period, amplitude, and phase of the observed oscillations and finally, (3) the definition of the specific physiologic control systems of which the observed oscillations are an expression.

In closing, a preliminary report of the first systematic study of ultradian rhythms in normal human subjects using techniques similar to those described here has just become available (Schaeffer, K.E., B.R. Clegg, C.R. Carey, J.H. Daugherty and B.B. Weybrew, Effect of isolation in a constant environment on periodicity of physiological functions and performance, National Aeronautics and Space Administration and US Naval Submarine Medical Center, Joint Report Number 488, Groton, Connecticut, 1967, AD650671) and I commend it to your attention.

ACKNOWLEDGEMENTS

The assistance of Mr Robert F. Bachert, Environmental Medicine Division, Aerospace Medical Research Laboratories, Wright-Patterson AFB, Ohio and Dr John Rummel, Manned Spacecraft Center, NASA, Houston, Texas in the development and application of the least squares spectrum and of Mrs Carole Smith in the preparation of this manuscript is gratefully acknowledged.

REFERENCES

1. Halberg, F., Physiological 24-hour rhythms: A determinant of response to environmental agents in man's dependence on the earthly atmosphere, K.E.Schaeffer, ed., New York, Macmillan, 1962.
2. Halberg, F., Engeli, M., Hamburger, C., and Hillman, D., Spectral resolution of low frequency small amplitude rhythms in excreted 17-keto-steroids, Acta Endocrinologica Suppl 103:5-54.
3. Sollberger, A., Biological Rhythm Research, Elsevier Publisher Co., New York, 1965.
4. Ashoff, J. Circadian Clocks, North-Holland Publishing Co., Amsterdam, 1965.
5. Burton, A.C., The range and variability of the blood flow in the human fingers and the vasomotor regulation of body temperature, Amer. J. Physiol. 127:437, 1939.
6. Iberall, A.S., Cardon, S.Z., Control in Biological Systems, Annals New York Academy of Sciences 117:445-515, 1964.
7. Iberall, A.S., Cardon, S.Z., Regulation and Control in Biological Systems, Proc. IFAC Symposium on Systems Engineering for Control Systems Design, Tokyo, 1965, pp.463-473.
8. Goodman, L. Alexander D.M. and Fleming, D.G., Oscillatory Behavior of Gas Exchange in Resting Man, IEEE Trans. on Bio-Medical Engineering. 13:57-64, 1966.
9. Wolf, W. (ed), Rhythmic functions in the living system, Ann. N.Y. Acad. Sci. 98:753-1326, 1962.
10. Schaeffer K.E., Clegg, B.R., Carey, C.R., Daugherty, J.H. and Weybrew, B.B., Effect of isolation in a constant environment on periodicity of physiological functions and performance, National Aeronautics and Space Administration and US Naval Submarine Medical Center, Joint Report Number 488, Groton, Connecticut, 1967 (AD650671).

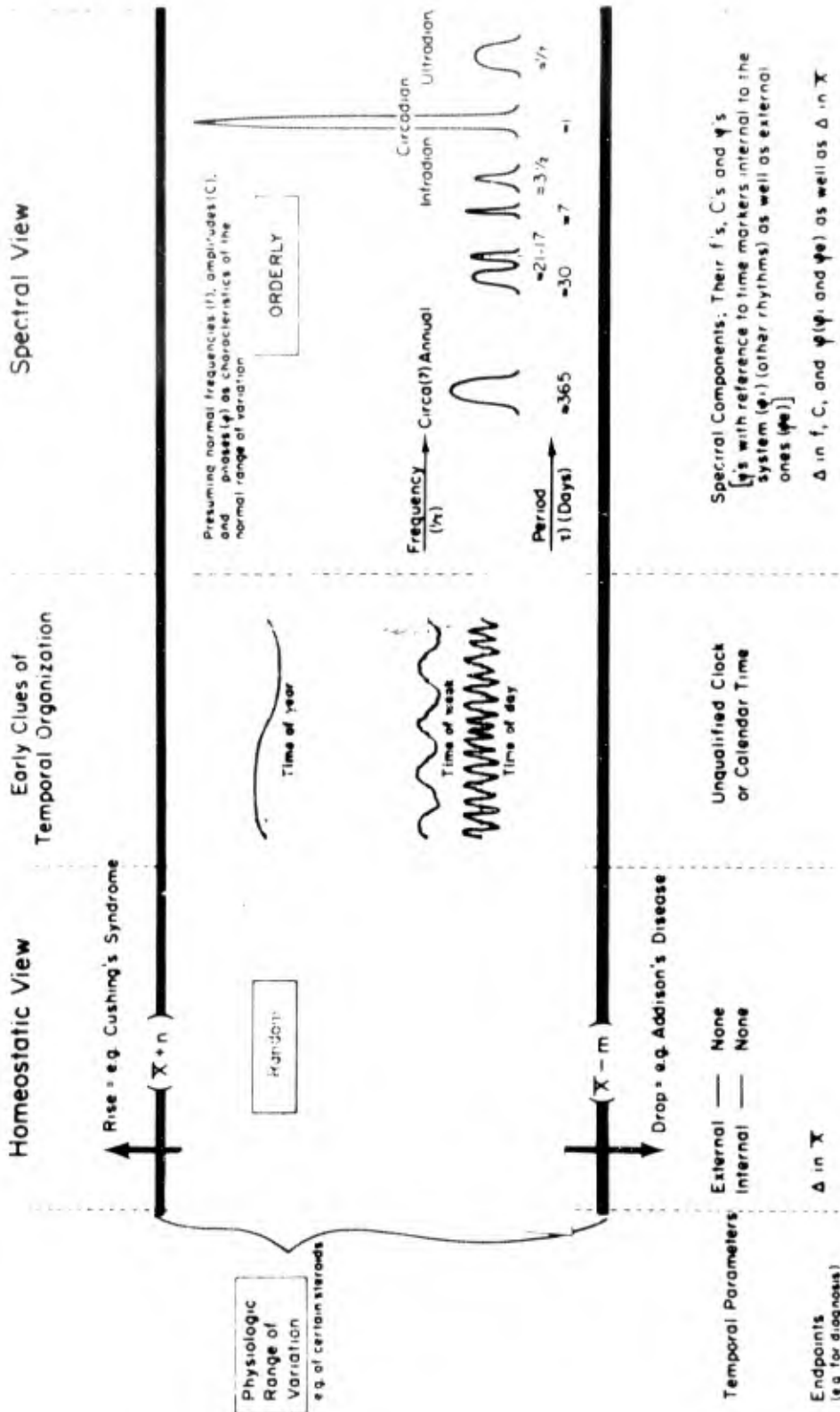

Fig. 1 (From Halberg, Reference 1) A schematic illustration contrasting the homeostatic and the spectral views of physiologic organization

<i>Term</i>	<i>Spectral Region</i>	<i>Range</i>
- Ultradian	Less than circadian	1-19.9 hours
- Circadian	About 24 hours	20-27.9 hours
- Infradian	Greater than circadian	1.6-5.9 days
- Circaseptan	About 7 days	6-8 days
- Circavigintan	About 20 days	17-23 days
- Circatrigintan	About 30 days	-
- Circannual	About 365 days	-

Fig. 2 The nomenclature for the periods of biological rhythms as proposed by Halberg

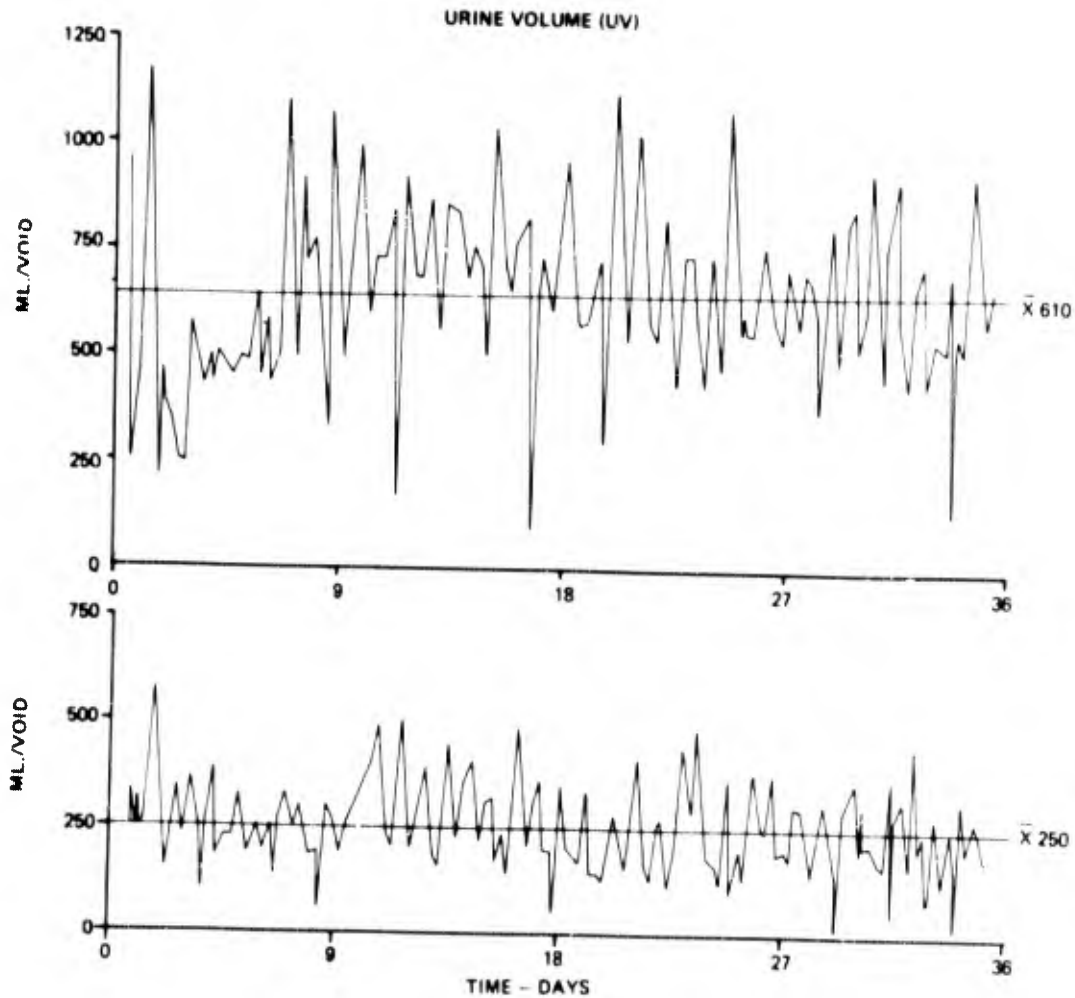

Fig. 3 Urine volume in ml/void for two subjects during a 36 day chamber confinement test. Mean values for the 36 day period are 250 and 610 ml

<i>Quiescent Fasting</i>	<i>Quiescent Food</i>	<i>Exercise Fasting</i>
0.75 ± 0.1 sec	0.75 ± 0.05 min	0.6 ± 0.05 sec
3.4 ± 0.6 min	3.3 ± 0.5 min	3.4 ± 5 min
8.8 ± 2.9 min	7.5 ± 1.9 min	12 ± 1.2 min
35 ± 14 min	36 ± 7 min	40 ± 4 min

Fig. 4 (From Iberall) Nominal periods in heart rate in a single subject during rest, fasting and exercise

LEAST SQUARES SPECTRUM

$$f(t) = C_0 + C \cdot \cos\left(\frac{2\pi}{\tau} t + \phi\right)$$

where

C_0 = constant term or level

C = amplitude

ϕ = phase

τ = trial period

Fitted to the given data for a set of trial periods.

Fig. 5 General form of the function fitted to the data by the method of least squares

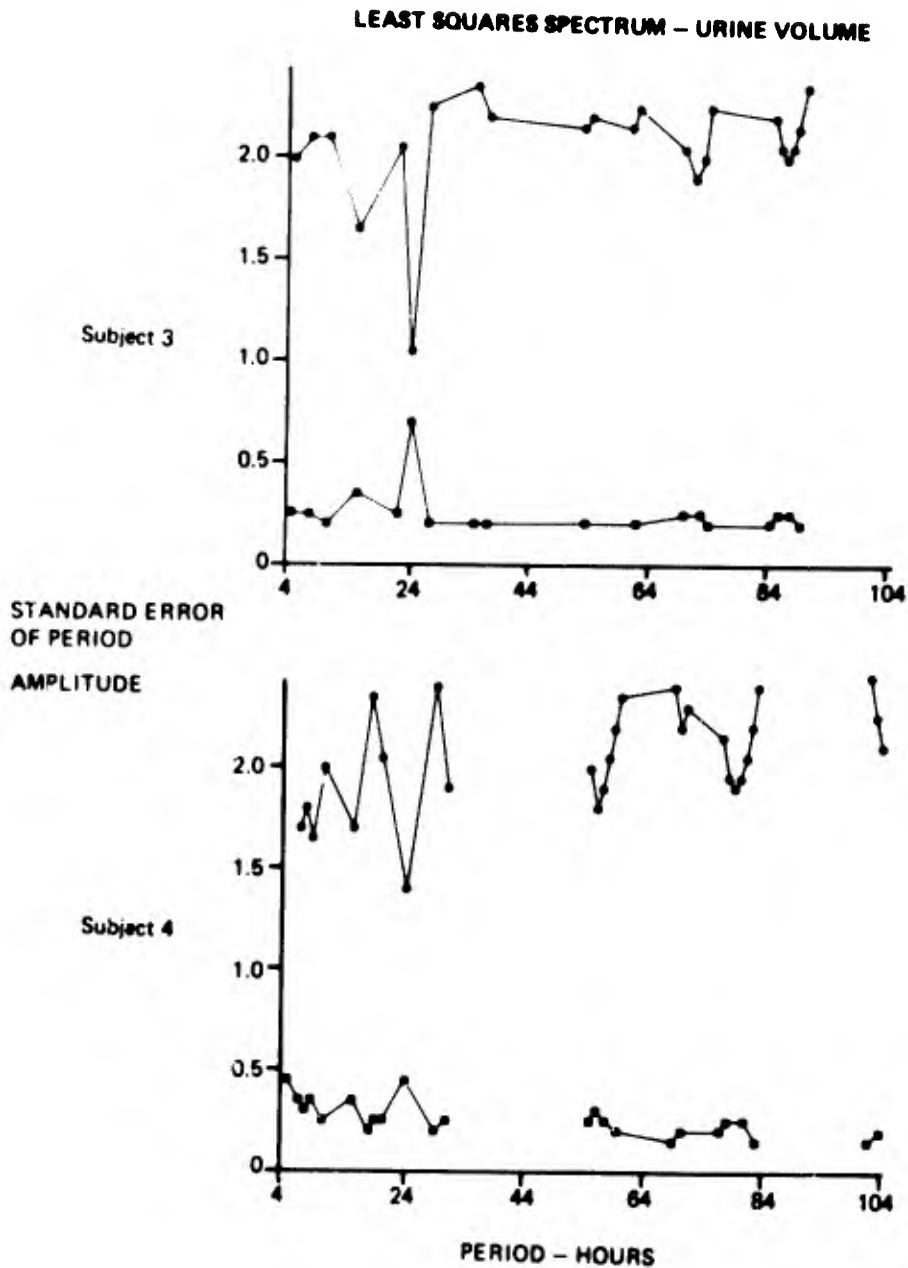

Fig. 6 The least squares spectrum of urine volume of the two subjects of figure 3 over a broad window of from 4 to 104 hours. The squares (lower lines) represent the relative amplitudes of each of the trial periods and the solid circles (upper lines) the standard error of the period

~ 15 hour

24 hour

~ 3½ days

~ 7 days

~ 17 days

~ 28 days

Fig.7 Nominal periods in urine volume in confined normal subjects

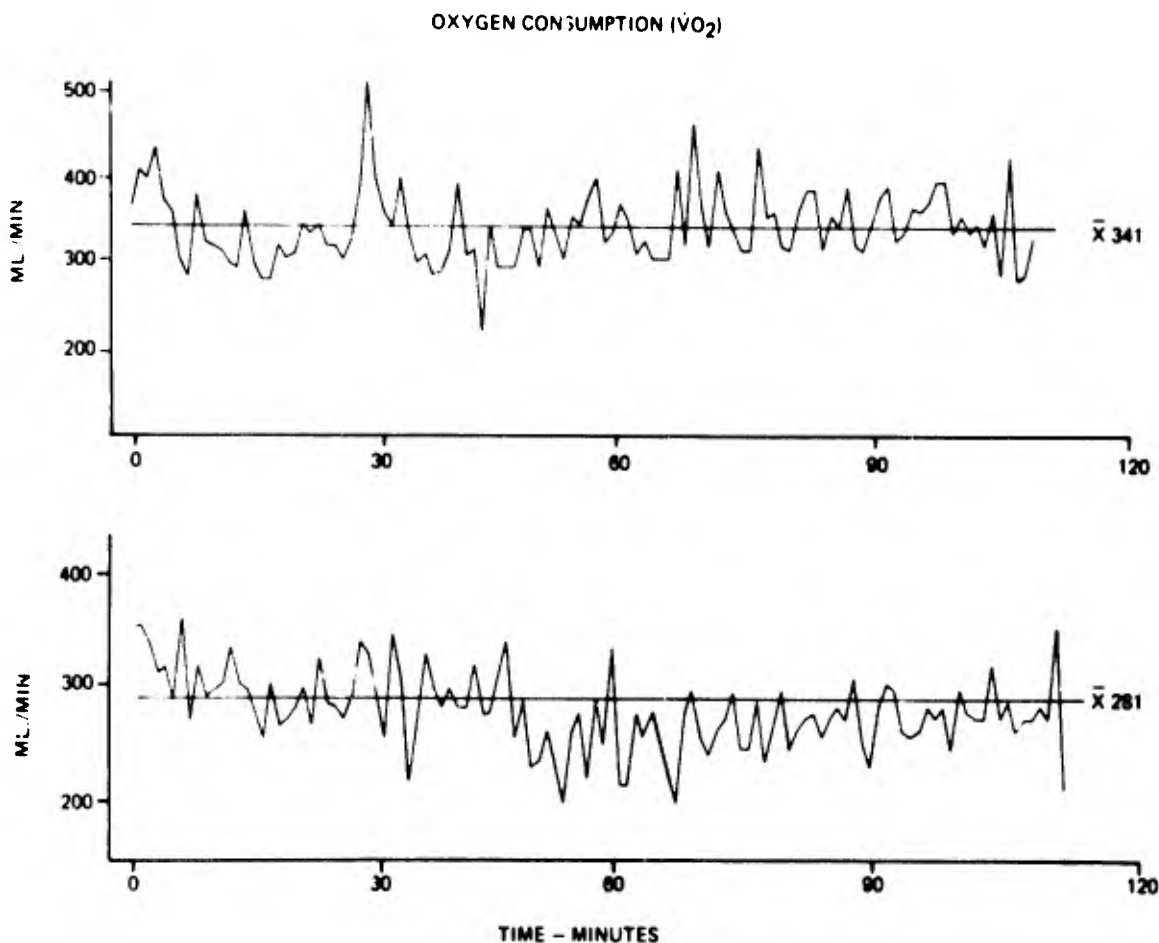

Fig.8 Oxygen consumption ($\dot{V}O_2$) of two seated resting subjects over two hours sampled at one minute intervals

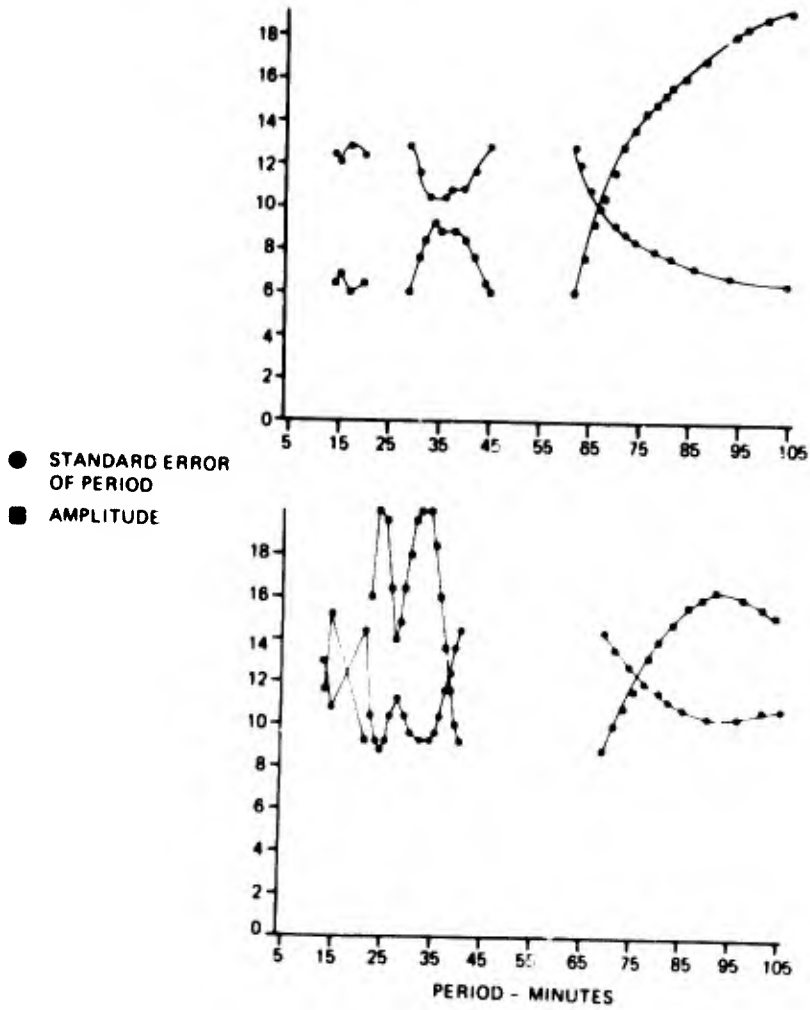

Fig.9 The least squares spectrum of minute to minute oxygen consumption of the two subjects of figure 8 over a broad window of from 5 to 105 minutes

\dot{V}	\dot{CO}_2	\dot{O}_2	RQ
2-4 h	2-4 h	2-4 h	2-4 h
1 h	1 h	1 h	1 h
20 min	20 min	20 min	15 min
10 min	10 min	10 min	10 min
4-6 min	4-6 min	4-6 min	4-6 min
1-2 min	1-2 min	1-2 min	1-2 min

Fig.10 (From Goodman et al, Reference 8) Nominal periods in resting ventilation and gas exchange in a resting subject as determined by Goodman et al

PERIODIC VARIATIONS IN INDICES OF HUMAN PERFORMANCE, PHYSICAL FITNESS,
AND STRESS RESISTANCE

K.E. KLEIN, H.M. WEGMANN, and H. BRÜNER

Institut für Flugmedizin der DVL, Bad Godesberg, Germany

SUMMARY

In order to estimate the existence and magnitude of rhythmic day-night variations in human performance, physical fitness and stress resistance the following variables were measured every three hours over a full day-night cycle: the reaction time and its individual constancy, the maximal psychomotor coordination ability, the SCHNEIDER index, the predicted VO_2 max, the cardiovascular responses to tilting, and the "time of usefull consciousness" in simulated altitude. The twenty four hours were split up into two experimental sessions, so that limited sedentary activity could be kept up between the test. All parameters (including body temperature, blood eosinophils, plasma-protein, aldolase and -17-OH-CS in addition) revealed relative rhythmic oscillations of the circadian type, the ranges of which varied for the group average between 1,4% (temperature) and 68% (17-OH-CS) of the total 24 hour average. - Negative extreme values showed up during the night hours for all cardiovascular parameters; consequently the SCHNEIDER index and the VO_2 max predicted from the heart rate level during submaximal exercise had their positive peaks or best values at this time of the day. While this phenomenon seems to be an "artificial" effect of the way to figure out physical fitness and probably is not identical with course of "fitness" itself, "true" positive night peaks were found for the altitude tolerance. The significance of the results for the applicability of functional tests and human efficiency during load is discussed.

1. INTRODUCTION

In animals the susceptibility to external stimuli shows significant cyclic variation during an approximately 24-hours time period. It has been demonstrated in many cases that even life or death from a given noxious agent - like noise and bacterial endotoxin (12), or ethanol (15) and ionizing radiation (34) - can be made experimentally a function of the circadian system phase. In man the sensitivity "phase map" (1) is full of gaps and almost limited, yet, to the day-time dependent incidence of certain clinical events and to cyclic variations in the responsiveness to drugs and other therapeutic actions (16, 17, 19, 31, 35, 38). Nevertheless, the present knowledge on this field justifies already the supposition, that the efficiency of man living or working under stressful conditions might be modified by a 24-hour rhythmic variation of his susceptibility and tolerance to adverse stimuli. In addition to the "dead point" (32) or the "minimum of readiness for mental performance" (29) a time of diminished bodily resistance, the "*horae minoris or variae resistentiae*" (11, 13), might well be of eminent practical importance, e.g. for flight safety. We had mainly this aspect in mind, when we started a series of experiments, in which we measured, among other parameters, some indices of fitness and stress tolerance under standardized conditions repeatedly over more than 24 hours.

2. METHODS

2.1. Series A

The experimental series A was accomplished with 13 men and 4 woman, who served as controls for inflight fatigue studies on Air Line crews. Under this aspect parts of the results have already been published elsewhere (23). The mean age of the group was 34.4[±]9.7 years. All participants were clinically healthy members of the laboratory staff. As such they were used to professional work from 8 a.m. to 5.30 p.m. for five days a week. For each participant the total experiment was split into two sections, in which the later mentioned biological tests were repeated every 3 hours. One period began at 9 a.m. and ended up at 12 p.m. the same day; some days later the second period, after a day of rest, began at 9 p.m. and was finished at 12 a.m. the following day. The two results of the overlapping parts of the two sections were averaged for each individual. Between the tests, both at day and night, the participants carried out the mainly sedentary activity, they were used to. The times of food intake (several light meals) were left to the individual; alcohol, drugs and stimulating beverages were not

allowed. All measurements were carried out after a 15 minutes rest period in supine position.

From the data published in this report, the following were obtained under these conditions: the oral temperature, the cardiac output, the cardiovascular index of SCHNEIDER (36), the number of eosinophils in blood, the simple reaction time to auditory as well as visual stimuli, and the individual variance of the reaction time. For the estimation of cardiac output the stroke volume was figured out from the bloodless measured pulse pressure by means of an equation given by BETZIEN (4). The individual variance of the reaction time was calculated from a sequence of 15 determinations of the reaction time measured in the same subject in irregular intervals within 3 minutes.

2.2. Series B

The experiments of series B were carried out with 9 male students, whose mean age was 23.8 ± 1.8 years; they all were used since years to the daily professional routine of university students. Here, they served as a control group for biochemical inflight studies on Starfighter pilots (42). In respect to activity meals, rest, and the sequence of the examinations the experimental conditions were kept exactly the same as in series A. From the results reported on here the total plasma protein, the plasma aldolase, and the free hydroxycorticosteroids (17-OH-CS) were taken from this group. The methods applied for the chemical analysis were published elsewhere (41).

2.3. Series C

In the experimental series C the mean age of 8 male students was 24.9 ± 1.5 years. Their social habit was that of university students, studying medicine or law, and as such was similar to the one of the other two groups. Through their participation in earlier experiments they had a great experience with the tests they were subjected to in this series:

A complex sensomotor coordination test, measuring the individual's maximal psychomotor performance over 10 minutes with the "Kugeltestgerät" (6, 27).

A physical exercise test on the bicycle ergometer, in which as an index of physical fitness the maximal oxygen uptake (VO_{2max}) is evaluated from the heart rate level during submaximal work by means of the nomogram of ÅSTRAND (3).

A tilt table procedure, similar to the one used by STEVENS (39), FASCEVELLI and LAMB (9), at which tilting to a 90° upright position was completed within 3-5 seconds, the total tilt time was 20 minutes,

and respiratory maneuvers (breath holding and hyperventilation) were included after the 11th minute; the cardiovascular responses given here are the averages of the data measured minute by minute between the 4th - 11th minute by ECG and cuff method while tilted and suspended in a parachute harness.

An altitude tolerance test, which was accomplished in a low pressure chamber at a simulated altitude of 7.500 m (287 mm Hg total pressure); the procedure, in which, among other parameters, the "time of usefull consciousness" is evaluated, was published earlier in detail (7).

Like in series A and B we have split up the total time, in which we studied a test, into two periods. But in order to avoid exhaustion by subjecting the participants too often to a rather stressful situation, we changed the time intervalls for the repetition of one test from 3 to 6 hours, and extended one period to 24 hours. So, we began the one period at 9 a.m. with tilting, and repeated this test every 6 hours till 9 a.m. the other day. In the same time period we carried out the submaximal physical exercise test, beginning at 12 a.m. and repeated it, also every 6 hours, each time in the middle of the interval between the tilt tests. We began the second 24-hour period for these tests some days later at 6 p.m. with tilting and proceeded in the same way as before, alternating tilt table and exercise in a sequence of 3 hours. Later on the same alternating mode was applied to a combination of the stressful altitude test and the easier psychomotor performance test, so that at the end of this series we had, like in series A and B, data from each of the 4 tests in 3-hourly time intervalls over, at least, one full day-night cycle. In contrary to the 2 proceeding series, however, during the night the subjects of series C were allowed to rest in supine position between the tests.

2.4. Statistics

The kind of the statistical treatment of the material was determined by our intention to study rather the average time-dependant variations, which are to be expected in a group of subjects with normal social habit in their responsiveness to the applied stimuli, than by the purpose to analyze the rhythmic character of the data. Therefore, the values of each parameter were averaged "vertically" to a mean 24-hour cycle of the total group, without previous adjustment of the phase differences in the individuals. In a way, the phase differences, however, were taken into account, when we averaged the differences between the positive and negative extrem values of the individual cycles to a "mean range of oscillation of the individuals" independently of their temporal position. The comparison between this individual mean and the "group range of oscillation", calculated from the extreme values of the averaged group cycle, gives

an indication of the magnitude of phase differences existing in the individual cycles.

In addition the t-test was applied and for graphical representation, we made use of the possibility, to smooth curves by the "running averages" (10), being aware, that this proceeding usually causes a substantial flattening of the curves, to be taken into account, when the variations shown graphically are to be evaluated in regard to their practical significance. - In our "circadian vocabulary" we followed in general the recommended terminology of ASCHOFF, KLOTTER and WEVER (2).

3. RESULTS AND DISCUSSION

3.1. Periodic variation in the functional state of the body at rest

The fact, that the functional state of the body at rest is subjected to a 24-hour rhythmic fluctuation, which is independent of awakesness and sleep, is known in principle since more than one hundred years. Meanwhile almost a hundred of individual functions have been studied under this aspect (32, 38). We have instanced some of them in table 1 to remind, that cyclic variations especially then are to be expected, when the functions are regulated or strongly influenced by the autonomic nervous system. The metabolism, the cardiovascular system and the adrenal activity participate directly or indirectly in the rhythmic shifts of the neuro-vegetative tonus. Even the aldolase, a cell enzyme of the glycolysis, demonstrates in its plasma level, likely via changes in the membrane permeability, the predominantly ergotropic phase during the day and the predominance of the parasympathic system at night. It must be of consequence for the result, in what phase of its basic functional state the body is hit by a stimulus. The level of many "conditioning" factors like metabolism, the cardiovascular or adreno-cortical activity etc., will modify the individual tolerance; it will depend at the end on the state of that organic system, which decides in the sum of the responses to a particular stress. We will have to come back to this subject in the next chapter, when we discuss phase differences in tolerance cycles.

3.2. Periodic variations in the response of the body to loading tests

3.2.1. Mental performance

The reaction time and the ability to perform a complex psychomotor action as quick and as accurate as possible had their best averages

between 2 and 4 p.m. and the lowest values almost at the same hours in the night (table 3, figure 1). By this course is the position of the "dead point" clearly indicated. The findings correspond in so far very well to the results compiled earlier on this field by many authors (32). With a 10-20% maximal fluctuation around the total average the range of oscillation is of the same magnitude as found recently in a performance cycle of a tracking task at a driving apparatus (18). Only the individual variance of the reaction time is in opposition to the concept of a diurnal "high" and nightly "low" of mental performance, as the "steadiness" was best at night, when the reaction itself was longest. But the lack of statistical significance for this cycle and the reverse course of the standard deviation of the reaction time leave the circadian rhythm of its individual "steadiness" an open problem, yet.

3.2.2. Tilt table

As it seemed to be of importance for the final evaluation of orthostatic "tolerance", we differentiated between the "levels" of the cardiovascular variables in the tilted position, and their "true" responses to the change in posture, i.e. their alterations from horizontal to vertical body position (table 2, figure 2). In its level heart rate, systolic blood pressure and pulse pressure showed a significant time dependancy with the peaks in the afternoon and the negative extreme values during the late night, or early morning. The responses exhibited in principle the same variation, but of minor extent. In heart rate, for instance, the difference between the positive and negative extreme values was 1.6 beats/min on average, and in pulse pressure a likewise non significant mean oscillation of 3.4 mm Hg was computed for the group. Only the systolic blood pressure showed a significant cyclic trend to decrease less in the afternoon and more during the night.

The tilt table "tolerance" is not easy to define, if - like in our experiments - fainting does not occur. Only differences in the cardiovascular responses in fainter and nonfainter may help in that case, to get in indication of what is "better" or "worse" in the reaction to tilting. If in this respect we make use of the results of STEVENS (39), then a bigger increase in heart rate and a smaller decrease in systolic blood pressure as well as in pulse pressure, is a symptom of a better tolerance. The application of this principle to our figures leads to the end, that tilt table tolerance is relatively better in the afternoon between 3 and 7 p.m., and worse in the late night at 3 to 6 a.m. But like in the active change of posture analyzed before (25), the mean group range of oscillation in the

cardiovascular responses is such, that we rather would like to speak only of a "trend" in orthostatic tolerance to variate cyclic in the demonstrated way. We should, however, not overlook the fact, that the mean oscillation range of the individuals is almost 3-4 times higher than that of the group.

3.2.3. Physical exercise

The 2 indices of physical fitness exhibited periodic variations with statistical significant differences in the values of each test. They differed substantially in the range of oscillation, which was 11% for the group in the predicted VO_2 max and 36% in the SCHNEIDER index. Surprisingly, in both tests the better indices or values came out at night, the worst results at 3 p.m.

The discussion of this phenomenon should begin with the statement, that "indices" of fitness were measured and not fitness itself. True physical fitness can only be evaluated properly by a maximal exercise test, the use of which in periodicity studies is difficult, however, for evident reasons. As some of the tests estimating fitness from submaximal work loads, have, yet, a very high statistical correlation to the true working capacity, their applicability in measuring fitness can not be doubted in principle. This is true, for instance, for the here used method of predicting the VO_2 max by use of the ÅSTRAND nomogram (24).

All "substitutional" fitness tests base on the fact, that the subjects with a higher performance capability for physical exercise, e.g. trained people, have lower heart rate levels, both at rest and during exercise. Consequently, in these methods lower heart rates are scored better, if measured under the same experimental conditions. If we keep these facts in mind and, moreover, consider the periodicity in heart rate (as it was analyzed in detail for the SCHNEIDER index before (25), and again appears here in the results of the tilt table experiment), then the described circadian course of the indices of fitness appears but as compulsory result of these interrelations.

Obviously both, the "parasympathic hemodynamics" (30) induced by physical training and the trophotropic phase of the autonomic nervous system at night, lead in some aspect to the same results, e.g. in heart rate levels. We doubt, however, without being able to prove it now, that the relative changes in the indices of fitness during the 24-hour cycle indicate any longer true variations of fitness itself. We rather believe, that the relative bradycardia at night, like the same symptom in the aged subject and in the state of starvation (14), might be accompanied by a relative reduction in the working capacity.

3.2.4. Simulated altitude

The 24 hour total average of the "time of usefull consciousness" in severe hypoxia was 5.6 min (table 3). The variation around this mean value was of the circadian type (figure 4) with an oscillation range of 2 min, or 34%, for the group average, and significant differences between the low values in the late afternoon and the long times in the early morning. The shortest time, the 4.7 min at 3 p.m., corresponds well to the 4.4 min measured before in a group of young healthy subjects between 2 and 5 p.m. (24).

In contrary to the indices of physical fitness is the time of usefull consciousness a direct parameter of the acute altitude tolerance. So, we have to establish the fact, that altitude tolerance itself has a nightly "high" and a diurnal "low". What, now, may be the causes, that here the functional state of the body at night is definitely superior to that of the day? The analyzation of the present knowledge on that field makes the following explanation most reasonable.

The altitude tolerance has no significant correlation to physical fitness (24), it improves with age (5, 37), and is independent of the cardiovascular responses (24), but at the same time is highly correlated in a negative way with the individual reaction of the adrenal cortex to an acute altitude exposure (41). Higher resting values and smaller responses of the 17-OH-CS plasma level were found in relation with relatively better altitude tolerances in unadapted (21, 24), as well as in altitude-adapted (20, 22) subjects. Moreover is this exactly the functional state of the adrenal cortex during the night in man with normal social habits: a higher level of 17-OH-CS (figure 4) and smaller responses of the same variable to a standardized stress or ACTH dose (15, 33, 40), so that the circadian periodicity in the activity of the adrenal cortex, perhaps in connection with the cycle of the basic oxygen uptake (20) could well be the reason for the particular day-night fluctuations found in the altitude tolerance. That adrenal cortex is not alone deciding, the course of the tolerance may easily be seen alone in the phase differences of the two variables (figure 4).

4. CONCLUSIONS

4.1. The significance of the circadian rhythms for the applicability of functional tests

A man is usually subjected to a functional test, in order to find out the position of the result on an empirical scale. The scale has mostly been established on the basis of results obtained with the

test in a control group during certain hours of the day; the early morning, the late evening and the night time will hardly ever be included in this basic sample. So it happens, that not only relative differences develop between the results of two experiments, which have not been carried out at the same time, but that moreover the absolute scale in use has validity, e.g. for the definition of "normal" or "unnormal" results, only for the hours it has been established from; application of the test at other times must lead to errors.

These difficulties may be avoided by the performance of tests at usual and comparable day times. For the definition of what are comparable times yet, the data given in table 1-3 might be of value, if average differences and standard deviation are accounted for.

More difficult is the avoidance of a mistake, which comes out, if subjects with different social habits are to be compared. A phase shift, as it was found in night workers, e.g. in 17-OH-CS level, makes sometimes even a comparison of those test results impossible, which have been obtained at the same time of day. Here only the knowledge and consideration of the differences in circadian phase solve the problem.

4.2. The significance of the circadian rhythms for man's efficiency

Two aspects seem to be of high significance in the estimation of circadian rhythm's influence on human efficiency: The "range of oscillation" and the "position of the peaks". (A third aspect, the effect of desynchronization on man's efficiency during absence of environmental synchronizers, is not subject of the report.)

A compilation of the oscillation ranges for both the group and the individual averages reveals the surprising differences existing between the variables in this respect (figure 5). The range extended from hardly 2% in temperature to almost 100% in 17-OH-CS level. The maximal oscillation of mental performance, fitness and altitude tolerance ranged roughly from almost 20% to approximately 50%. Distinctly is the significance of the circadian rhythm's influence on the efficiency reflected in the following 2 observations: 1. the maximal variation in the cycle of the psychomotor performance corresponds to the maximal effect of 0.09% blood alcohol measured with the same procedure in comparable subjects (26); 2. the same difference, as found in the extreme values of the altitude tolerance, has been observed earlier, again with the same method, as temporary sequela of an infectious disease (8).

In spite of the knowledge of phase differences the results of earlier biorhythmic research in man have led to the opinion of a general diurnal "high" and a nightly "low" in human efficiency (28,29). Though, we know meanwhile, that the problem is certainly

more complicated, than it is expressed in this concept, our results generally point in the same direction again. The cycles of mental performance, of tilt table tolerance and, likely, of physical fitness exhibited their peaks on average between approximately 1 and 7 p.m. and their troughs at about 2-6 at night. The list of similar running sensitivity rhythms could easily be extended (13), if it were sure, that the results found in mouse may be applied to man by neutralizing a difference in timing through a 12 hours shift (15).

Only one variable in our results, the time of useful consciousness in altitude, showed a completely inverse running cycle, so that, in fact, we must assume, that a pilot, who is subjected to hypoxia, is almost 50% better off at 3 a.m., compared with his altitude tolerance at 3 p.m. This, however, should warn us of an unsupported generalisation of the opinion, that as a rule by circadian rhythm healthy man's efficiency from a 24-hour total average is lowered at night and increased during the day.

REFERENCES

1. ASCHOFF, J.: Gesetzmäßigkeiten der biologischen Tagesperiodik. Dtsch. Med. Wschr. 88, 1963, 1930-1937.
2. ASCHOFF, J., KLOTTER, K. and R. WEVER: Circadian Vocabulary. In: ASCHOFF, J. (edit.), Circadian clocks. Amsterdam: North-Holland Publishing Co. 1965, p. X-XIX.
3. ASTRAND, P.O. and J. RHYMING: A nomogram for calculation of aerobic capacity (physical fitness) from pulse rate. J.appl. Physiol. 7, 1954, 218-221.
4. BETZIEN, G.: Über inspiratorische Hypoxie als Test für die menschliche Leistungsbreite. Int.Z.angew.Physiol. 17, 1958, 190-203.
5. BRÜNER, H., DIETMANN, K. und K.E.KLEIN: Der Sauerstoffmangeltest. Über Grundlagen und Beziehungen zu regulativen Vorgängen im Organismus. Int.Z.angew.Physiol. 18, 1959, 1-12.
6. BRÜNER, H., JOVY, D. und K.E. KLEIN: Ein objektives Meßverfahren zur Feststellung der psychomotorischen Leistungsbereitschaft. Int. Z. angew. Physiol. 18, 1960, 306-318.
7. BRÜNER, H., JOVY, D. and K.E. KLEIN: Hypoxia as a stressor. Aerospace Medicine 32, 1961, 1009-1018.
8. BRÜNER, H. JOVY, D., K.E. KLEIN und S. RUFF: Zur Beurteilung der biologischen Leistungsreserve eines Piloten. In: BLENK, H. (edit.): Jahrbuch 1962 WGLR. Braunschweig: Friedr.Vieweg u. Sohn 1963, S. 576-581.
9. FASCENELLI, F.W. and L.E. LAMB: Biomedical monitoring during dynamic stress testing. V. Tilt table orthostatic tolerance test. Aerospace Medicine 37, 1966, 939-942.
10. GUILFORD, J.P.: Fundamental statistics in psychology and education. New York-Toronto-London: McGraw Hill Book Co, Inc. 1956.
11. HALBERG, F.: The 24-hour scale, a time dimension of adaptive functional organisation. Persp.Biol.Med. 3, 1960, 491-506.
12. HALBERG, F.: Circadian rhythms, a basis of human engineering for aerospace. In: FLAHERTY (edit.): Psychophysiological aspects of space flight. New York: Columbia University Press 1961, p. 166-194.
13. HALBERG, F.: Physiological 24-hour rhythms: A determinant of response to environmental agents. In: SCHAEFFER, K.E. (edit.): Man's dependance on the earthly atmosphere. New York: The Mac Millan Co. 1962, p. 48-96.
14. HARTMANN, H. und F. NOLTENIUS: Über die körperliche Leistungsfähigkeit und die Höhenfestigkeit im Hungerzustand. Luftfahrtmedizin 1, 1936, 44-48.
15. HAUSS, E.: Periodicity in response and susceptibility to environmental stimuli. Ann. N.Y. Acad. Sci. 117, 1964, 292-319.

16. HILDEBRANDT, G.: Über tagesrhythmische Steuerung der Reagibilität. Arch.Phys.Th^{er}. 9, 1957, 293-302.
17. HILDEBRANDT, G., ENGELBERTZ, P. und G. HILDEBRANDT-EVERS: Physiologische Grundlagen für eine tageszeitliche Ordnung der Schwitzprozeduren, dargestellt mit einer Methode zur fortlaufenden Registrierung der Hautwasserabgabe. Z.klin.Med. 152, 1954, 446-461.
18. JANSEN, G., RUTENFRANZ, J. und R. SINGER: Über eine circadiane Rhythmik sensumotorischer Leistungen. Int. Z. angew. Physiol. 22, 1966, 65-83.
19. JORES, A.: Physiologie und Pathologie der 24-Std-Rhythmik des Menschen. Erg.Inn.Med. 48, 1935, 574-625.
20. JOVY, D., BRÜNER, H., KLEIN, K.E. and H.M. WEGMANN: Adaptive responses of adrenal cortex to some environmental stressors, exercise and acceleration. In: MARTINI, L. and A. PECILE (edit.): Hormonal Steroids. Vol.2. New York and London: Acad.Press 1965, p. 545-553.
21. KLEIN, K.E., BRÜNER, H. and D. JOVY: Measuring the individual stress sensitivity by means of oxygen want. In BUCHANAN-BARBOUR and H.E. WITTINGHAM (edit.): Human Problems of supersonic and hypersonic flight. Oxford-London-New York-Paris: Pergamon Press 1962, p. 455-461.
22. KLEIN, K.E., BRÜNER, H., JOVY, D. and H.M. WEGMANN: Human adaptation to altitude, heat, cold, physical exertion, acceleration, radiation in space flight. NASA-TT-F 9158. Washington D.C.: National Aerospace Administration 1964.
23. KLEIN, K.E., BRÜNER, H. und S. RUFF: Untersuchungen zur Belastung des Bordpersonals auf Fernflügen mit Düsenmaschinen. Z. Flugwissenschaften 14, 1966, 109-121.
24. KLEIN, K.E., BRÜNER, H., E.D. VOIGT and H.M. WEGMANN: Comparative studies on physiological indices of fitness in man under exercise, low pressure and acceleration. In: YOSHIMURA, H. and J.S. WEINER (edit.): Human adaptibility and its methodology. Tokyc: Japan Society for the Promotion of Sciences 1966, p. 234-247.
25. KLEIN, K.E., BRÜNER, H., FINGER, R., SCHALKHÄUSER, Kl. und H.M. WEGMANN: Tagesrhythmik und Funktionsdiagnostik der peripheren Kreislaufregulation. Int.Z.angew.Physiol. 23, 1966, 125-139.
26. KLEIN, K.E., BREUKER, Kl., BRÜNER, H. und H.M. WEGMANN: Blutalkohol und Flugtüchtigkeit. Versuch einer Erarbeitung von Richtwerten für die allgemeine Luftfahrt. Int.Z.angew.Physiol. 24, 1967, 254-267.

27. KLEIN, K.E., BRÜNER, H., WEGMANN, H.M. und P. BAUSZAT: Die Veränderung der psychomotorischen Leistungsbereitschaft als Folge pharmakodynamischer Einwirkung verschiedener Substanzen mit potentiell sedierendem Effekt. *Arzneim.-Forsch. (Drug Res.)* 17, 1967, 1048-1051.
28. LEHMANN, G.: Das physische Leistungsvermögen des Menschen. *Hdbuch ges. Arbeitsmed. Bd.I. Arbeitsphysiologie*. Berlin-München-Wien: Urban und Schwarzenberg 1961, S. 321-362.
29. LEHMANN, G.: Effect of Environmental factors on Biological Cycles and Performance of Work. In: SCHAEFFER, K.E. (edit.): *Man's dependance on the earthly atmosphere*. New York: The Mac Millan Co. 1962, p. 381-387.
30. MELLEROWICZ, H.: Herz und Blutkreislauf beim Sport. In: ARNOLD, A. (edit.): *Lehrbuch der Sportmedizin*. Leipzig: A. Barth 1956, S. 129-189.
31. MENZEL, W.: Der 24-Stundenrhythmus des menschlichen Blutkreislaufes. *Erg.Inn.Med.Kinderheilk.* 61, 1941, 1-12.
32. MENZEL, W.: *Menschliche Tag-Nacht-Rhythmik und Schichtarbeit*. Basel/Stuttgart: Schwabe und Co. 1962.
33. PERKOFF, G.J., EIK-NES, K., NUGENT, C.A., NIMER, R.A., RUSCH, L., SAMUELS, L.T. and F.H. TYLER: *J.clin.Endocrinol.* 19, 1959, 432 (cited from HAUSS).
34. PIZARELLO, D.J., ISAAC, D., and K.E. CHUA: *Science* 145, 1964, 286-291 (cited from ASCHOFF, 1963).
35. REINBERG, A.: Hours of changing responsiveness in relation to allergy and the circadian adrenal cycle. In: ASCHOFF, J. (edit.): *Circadian clocks*. Amsterdam: North-Holland Publishing Co. 1965, p. 214-218.
36. SCHNEIDER, E.C.: A cardiovascular rating as a measure of physical fatigue and efficiency. *J.Am.Med.Ass.* 74, 1920, 1507-1518.
37. SCHWARZ, W.: Der Einfluß des Alters auf die Widerstandsfähigkeit gegen Sauerstoffmangel. *Luftfahrtmedizin* 1, 1936, 39-43.
38. SOLLBERGER, A.: *Biological rhythms research*. Amsterdam-London-New York: Elsevier Publishing Co. 1965.
39. STEVENS, P.M.: Cardiovascular dynamics during orthostasis and the influence of intravascular instrumentation. *Am.J.Cardiol.* 17, 1966, 211-218.
40. UNGAR, F. and F. HALBERG: In vitro exploration of a circadian rhythm in adrenocorticotropic activity of C mouse hypophysis. *Experientia* 19, 1963, 158-163.
41. WEGMANN, H.M., BRÜNER, H., KLEIN, K.E. and E.D. VOIGT: Enzymatic and hormonal responses to exercise lowered pressure and acceleration in human plasma and their correlation to individual tolerances. *Fed.Proc.* 25, 1966, 1405-1408.

42. WEGMANN, H.M., KLEIN, K.E. und H. BRÜNER: Die Auswirkung fliegerischer Belastung auf einige Blutkomponenten. Int. Z. angew. Physiol. 23, 1967, 293-304.

Table 1. Circadian rhythm of body temperature, cardiac output (AFP) and blood parameters

Significant differences ($P \leq 0.05$) to the values at:+06⁰⁰, (+)09⁰⁰, **12⁰⁰, (*)15⁰⁰, ***18⁰⁰, (+++)21⁰⁰, (++)24⁰⁰, *03⁰⁰, and ++ to \bar{x}

n	06 ⁰⁰	09 ⁰⁰	12 ⁰⁰	15 ⁰⁰	18 ⁰⁰	21 ⁰⁰	24 ⁰⁰	03 ⁰⁰	\bar{x}	range of oscillation group indiv. mean	
oral temperature	36.2 +0.9 -0.9	36.4 +0.6 -0.6	36.4 +0.8 -0.8	36.6 +0.6 -0.6	36.7 +0.9 -0.9	36.6 +1.3 -1.3	36.3 +1.0 -1.0	36.2 +1.4 -1.4	36.4 +0.4 -0.4	0.5	0.7 +0.1 -0.1
cardiac output (AFP)	4.31 +1.03 -1.03	4.61 +1.38 -1.38	4.83 +1.25 -1.25	5.16 +1.53 -1.53	4.78 +1.45 -1.45	4.86 +1.07 -1.07	4.61 +1.22 -1.22	4.36 +1.16 -1.16	4.69 +0.75 -0.75	0.86	1.21 +0.42 -0.42
plasma protein	7.5 +0.4 -0.4	8.1 +0.9 -0.9	8.3 +1.2 -1.2	8.4 +1.0 -1.0	7.9 +0.9 -0.9	7.6 +0.3 -0.3	7.2 +0.2 -0.2	7.3 +0.8 -0.8	7.9 +0.3 -0.3	1.2	2.1 +1.5 -1.5
plasma aldolase	3.15 +1.3 -1.3	2.96 +0.6 -0.6	2.49 +0.4 -0.4	2.37 +0.5 -0.5	2.27 +0.4 -0.4	2.47 +0.3 -0.3	2.80 +0.4 -0.4	3.08 +0.7 -0.7	2.70 +0.4 -0.4	0.88	1.4 +0.4 -0.4
blood eosinophils	175 +99 -99	152 +86 -86	122 +75 -75	117 +62 -62	137 +83 -83	151 +93 -93	165 +79 -79	169 +106 -106	149 +85 -85	58	83 +62 -62
17-OH-CS	16.9 +4.3 -4.3	13.9 +5.0 -5.0	12.2 +2.3 -2.3	12.3 +2.8 -2.8	10.4 +2.2 -2.2	8.8 +2.4 -2.4	9.3 +4.8 -4.8	11.9 +2.2 -2.2	11.9 +1.7 -1.7	8.1	10.2 +5.0 -5.0

Table 2. Circadian rhythm of cardiovascular responses to tilting

Significant differences ($P \leq 0.05$) to the values at:

+06⁰⁰, (+)09⁰⁰, **00, **12⁰⁰, (*)15⁰⁰, ***18⁰⁰, (++)24⁰⁰, *03⁰⁰, and ++ to \bar{x}

n	06 ⁰⁰	09 ⁰⁰	12 ⁰⁰	15 ⁰⁰	18 ⁰⁰	21 ⁰⁰	24 ⁰⁰	03 ⁰⁰	\bar{x}	range of oscillation	
										group mean	indiv. mean
heart rate 8	83.4 +10.0	89.1 +9.9	91.3 +6.3	+* 93.6 +8.3	+* 90.8 +9.0	+* 89.6 +8.7	86.3 +8.5	83.9 +9.1	88.4 +6.8	10.2	18.1 +5.9
	*** 111	+* 113	+* 116	+* 119	(+) 121	+* 118	* 117	*** 110	115.6 +6.8	11.0	14.9 +4.3
systolic blood press. 8	+* 19.6	+* 24.1	+* 25.0	+* 29.9	+* 26.6	+* 28.4	+* 25.0	++ 19.3	24.8 +4.9	10.6	17.0 +3.5
	+5.6	+5.6	+8.5	+4.6	+8.5	+8.1	+6.4	+4.6	20.0 +3.1	1.6	3.5 +1.6
change of heart rate 8	+4.6	+3.8	+6.4	+4.3	+5.3	+5.2	+5.9	+2.8	20.0 +3.1	1.6	3.5 +1.6
	-4.3	-2.9	-2.1	-0.6	-0.9	-3.0	-2.5	-3.9	-2.5 +3.9	-3.7	-11.4 +5.9
change of blood press. 8	+5.5	+5.8	+3.2	+4.8	+6.2	+3.0	+7.0	+5.2	-2.5 +3.9	-3.7	-11.4 +5.9
	-20.1 +5.2	-19.9 +7.1	-19.3 +5.8	-19.1 +8.3	-18.4 +7.5	-18.6 +7.9	-19.0 +6.4	-21.8 +3.9	-19.5 +4.8	-3.4	-13.0 +2.6

Table 3. Circadian rhythm of human performance, indices of fitness and hypoxic stress resistance

Significant differences ($P \leq 0.05$) to the values at:+06⁰⁰, (+)09⁰⁰, **12⁰⁰, (*)15⁰⁰, (++)24⁰⁰, *03⁰⁰, and ++ to \bar{x}

n	Time								\bar{x}	range of oscillation	
	06 ⁰⁰	09 ⁰⁰	12 ⁰⁰	15 ⁰⁰	18 ⁰⁰	21 ⁰⁰	24 ⁰⁰	03 ⁰⁰		group mean	individ. mean
absolute reaction time 17	17.0	16.5	16.4	16.0	16.1	16.8	17.0	17.5	16.7	1.5	2.5
	+2.9	+2.1	+1.9	+2.1	+2.2	+2.1	+2.3	+2.9	+2.1	+1.0	10 ⁻² sec
individual variance	2.50	2.59	2.58	2.62	2.70	2.54	2.51	2.48	2.57	0.22	0.38
				*(++)	*	+*	(*)				
psychomotor performance	64.1	68.6	69.9	70.9	68.9	68.8	66.2	64.0	67.7	6.9	9.5
	+4.4	+5.0	+5.5	+5.5	+5.2	+3.9	+4.4	+4.8	+3.9	+2.4	index
SCHNEIDER index	12.3	11.2	10.4	9.4	10.2	10.3	11.4	13.4	11.1	4.0	7.0
	+3.2	+3.2	+3.8	+4.7	+4.3	+3.4	+2.3	+1.7	+2.7	+3.5	index
predicted VO ₂ max	3.41	3.31	3.23	3.14	3.21	3.31	3.37	3.50	3.31	0.36	0.47
	+0.3	+0.3	+0.2	+0.3	+0.3	+0.2	+0.3	+0.3	+0.3	+0.16	l/min
useful consciousness in hypoxia	6.6	5.8	5.3	4.7	4.8	5.2	6.0	6.3	5.6	1.9	2.9
	+2.3	+1.8	+1.6	+1.7	+1.6	+0.9	+1.8	+2.9	+1.5	+2.1	min

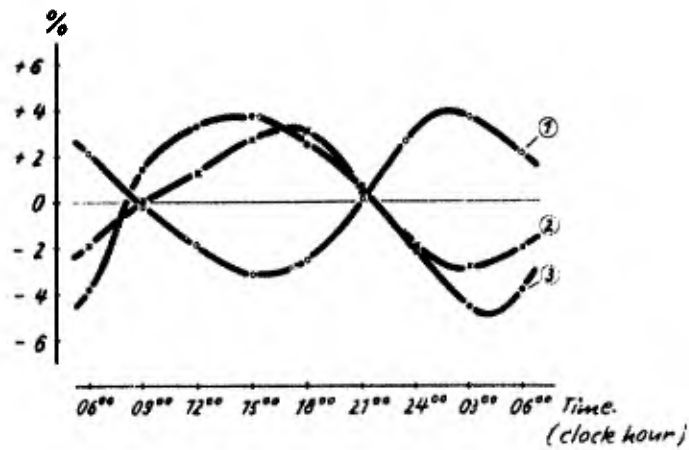

Figure 1: Circadian rhythm of reaction time (1), its individual variance (2), and of psychomotor performance (3).

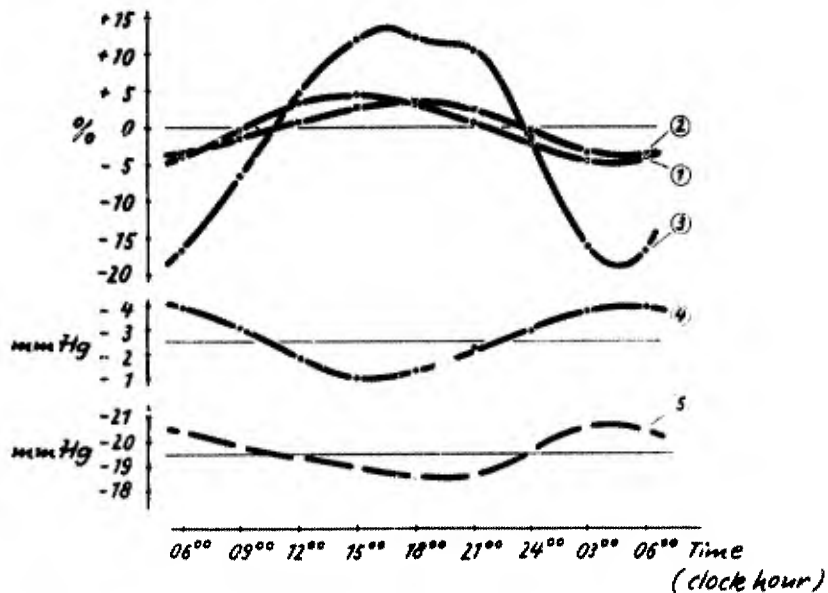

Figure 2: Circadian rhythm of cardiovascular responses to tilting (1 heart rate, 2 systolic blood pressure, 3 pulse pressure, 4 change of syst. blood press., 5 change of pulse press.).

(① predicted VO_2 max, ② Schneider index)

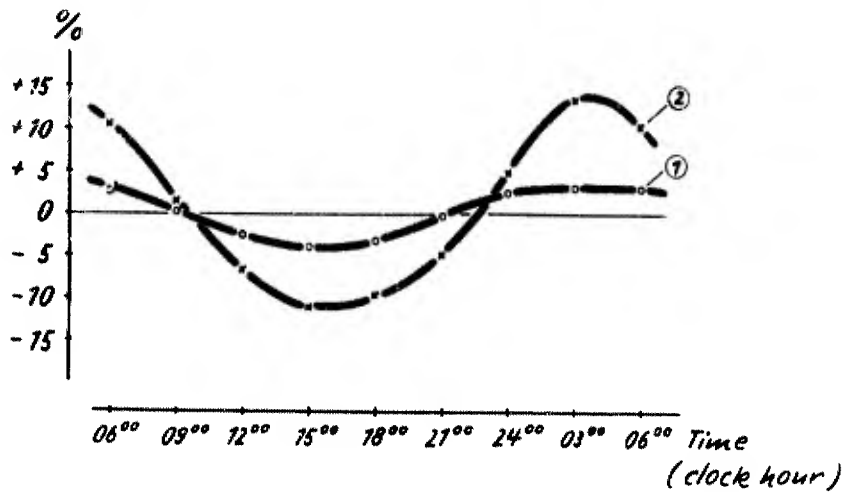

Figure 3: Circadian rhythm of indices of physical fitness.

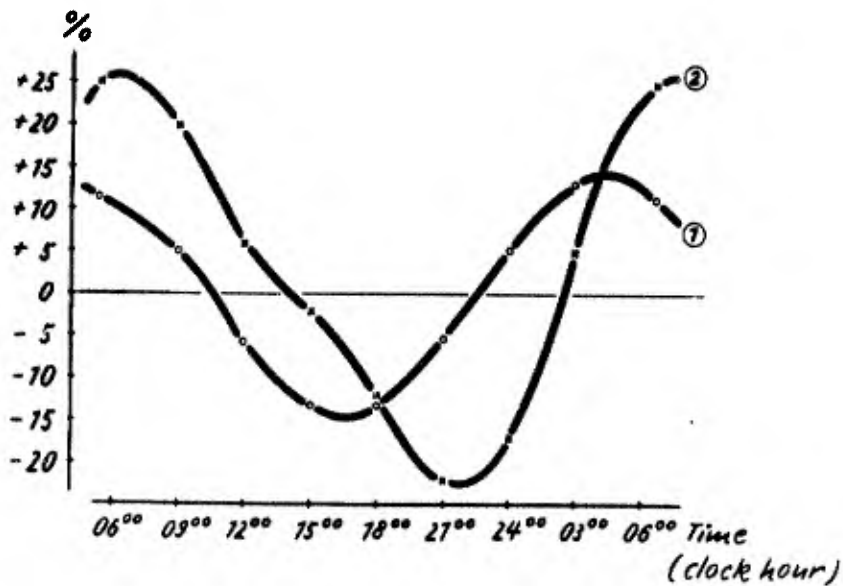

Figure 4: Circadian rhythm of ① the "time of useful consciousness" in hypoxia (inspir. P_{O_2} 50.4 mm Hg) and ② the plasma level of 17-OH-CS.

- | | |
|------------------------------------|----------------------------------|
| 1 temperature | 8 predicted VO_2 max |
| 2 reaction time | 9 SCHNEIDER index |
| 3 psychomotor performance | 10 time of usefull consciousness |
| 4 cardiac output - RFP | 11 plasma protein |
| 5 systolic blood pressure (tilted) | 12 plasma aldolase |
| 6 heart rate (tilted) | 13 blood eosinophils |
| 7 pulse pressure (tilted) | 14 plasma 17-OH-CS |

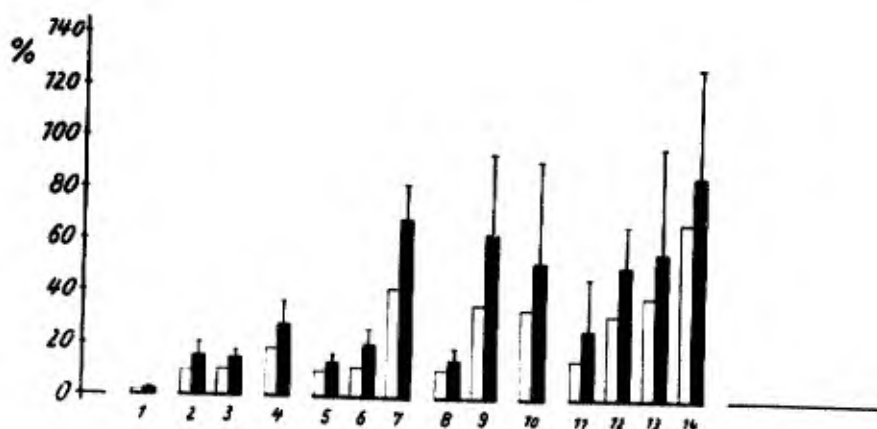

Figure 5: Range of oscillation (□ group average, ■ individuals average).

BLANK PAGE

PILOT RESPONSE UNDER GROUND SIMULATION CONDITIONS
AND IN FLIGHT

by

Wing Commander A.M. Hammerton Fraser,
J.M. Rolfe and Squadron Leader E.M.B. Smith

Flight Skills Laboratory,
RAF Institute of Aviation Medicine,
Farnborough, Hants

SUMMARY

The physiological responses of a group of pilots were recorded while at rest and while undertaking a given flight plan under one of three situations, namely:-

- (i) In a fixed-base simulator
- (ii) In a moving base simulator
- (iii) In flight

The object of the experiment was to determine the rank order of the subjects in terms of the magnitude of their physiological responses when resting, and the effect of task performance in this order. The results obtained indicated that there was consistency in rank order between subjects, but the degree of consistency varied with the physiological measure employed. The results also indicated differences in the magnitude of physiological response between resting and performing. The size of the differences was also shown to be dependent upon the situation in which the task was performed and the type of manoeuvre being undertaken.

A method of combining a subject's different physiological responses is demonstrated and conclusions are drawn as to the value of the results in assessing simulator fidelity.

PILOT RESPONSE UNDER GROUND SIMULATION CONDITIONS AND IN FLIGHT

Wing Commander A.M.Hammerton Fraser,
J.M.Rolfe and Squadron Leader E.M.B.Smith

INTRODUCTION

The flight simulator is a most useful tool for the investigation of many aspects of human behaviour in relation to flying. This fact was realized as long ago as 1923 by Reid and Burton (1), who in their own researches suggested that a device which required subjects to make responses similar to those used to fly an aeroplane could be used to:-

1. Test subjects' ability to fly and land successfully.
2. Test the rate of subjects' progress in the acquisition of flying skill.
3. Train pupils to acquire on the ground those particular co-ordinations necessary for aeroplane control.
4. Classify subjects for different forms of flying service.

The potential of the simulator has been extended somewhat with the progress of time and the development of new techniques, but, as Fraser (2) points out, the purpose of simulation is still to provide a method for the acquisition of knowledge under circumstances where, for a variety of reasons, the acquisition of that knowledge from the original source would be impracticable.

The simulation scientist has much in common with the illusionist. Both seek to convince that what is being experienced is real, but both know that they provide only simulacrum of reality, and success with a subject depends on their skill in the science and art of presentation and persuasion. However, the simulation task is more difficult, because the practitioner is attempting to do something much more complex than producing innumerable rabbits from one opera hat, but also because, in the case of the simulator, those who have to be "fooled" play an integral part in sustaining the illusion. The pilot flying a simulator does not only sit and observe the illusion. He responds to the states created by the simulation and his responses produce, in turn, new states to which he must again respond. In a sense he comes right in close and inspects the illusion in the greatest detail. He is in control and can subject the system to the most rigorous scrutiny. Any inconsistency between aircraft and simulator will reduce the power of the illusion and will result in the pilot not behaving in the same way as he would have done had he really been flying. Such a state of affairs is far from desirable, for the utility of a simulator depends on its ability to elicit, from the pilot on the ground, the same sort of response he would make in the air. It is this criterion which is used in assessing the fidelity of a simulator.

It must then be asked, what responses can be used which are indicative of the fidelity existing between flight and the simulation of flight? This paper describes an experiment in which the responses studied were variations in subject's physiological activity on the ground and in the air.

One of the major problems in using physiological measures is that of determining the extent of the disturbance in relation to normal, and indeed to define a norm. As each subject is very much an individual, and produces a particular and idiosyncratic response, it is always necessary to use each subject as his own control and to establish some standard condition against which comparisons can be made. The experimental paradigm set out above is the same as that used by Gemelli in his researches in Italy between 1918 and 1938 (3). He set about the investigation of subject response to particular situations and stresses by expressing each response in terms of a graphic representation of the deviation from normal. It should be noted that in his own researches Gemelli measured respiration, pulse and blood pressure before, during and after a one hour flight.

Whilst the intent may not have altered with the passage of time, the equipment and techniques available for such investigations today most certainly have. It is now possible, by means of telemetry or in-flight recording devices, to record and store, during flight, data which can be fed directly into a computer on the ground. This means that a wider range of measures may be used and also prompts the experimenter to make use of larger subject groups, a factor which is of importance in a situation where individuality of response is soon apparent. This phenomenon was noted and discussed by Benson and Rolfe in their paper to this assembly last year (4).

The present experiment took place at the Royal Air Force Institute of Aviation Medicine, and used the simulator of the Flight Skills Laboratory (Fig.1) (5) for the earthbound aspects of the investigation and the Hunter T7 aircraft of the Flight Research Section for the airborne studies (Fig.2). The experiment was designed to compare the physiological responses of nine experienced pilots while they carried out the same instrument flight plan under three different conditions, namely:

1. Flight in the Hunter T7
2. Simulated flight in the simulator with pitch motion
3. Simulated flight in the same simulator without motion.

Each subject did the three runs at least 24 hours apart and in a carefully randomized order. As it was not considered practical to determine true basal physiological levels, an attempt was made to achieve a consistent standard for comparison before each run by sitting the subject in the inoperative simulator cockpit for fifteen minutes, playing light music through his earphones to exclude background noise, and recording his physiological activity for the last five minutes. The subject then left the simulator and after about thirty minutes he was installed in either the aircraft or the simulator for the experimental run. The experimental flight pattern (Appendix A) which consisted of a series of climbing and descending turns, through set heights and headings, separated by periods of straight and level flight, was preceded and followed by resting periods during which the experimenter flew the aircraft or simulator straight and level. In order to minimise extraneous disturbances during flight one of the experimenters remained in charge of radio communication and of collision avoidance.

The physiological measures used were heart rate, skin resistance, and respiratory rate. Heart rate was measured by recording an e.c.g. from two chest electrodes of the type designed by one of the experimenters (Fig.3) (6). Skin resistance was measured between a wrist electrode and a dry silver disc electrode on the tip of the left middle finger. This site was chosen for this series of experiments because the ball of the thumb, which is the preferred site for this measurement, is subject to frequent changes of pressure when the subject is controlling a simulator or aircraft. The subject wore his own oxygen mask and breathed through a pneumotachograph which was inserted in the respiratory hose.

For simulator runs the physiological signals were processed by a digital system (Fig.4) which is described in greater detail elsewhere (7). The data were transposed into ten second counts or samples and recorded on punched tape. For flight runs the physiological signals were recorded in analogue on a specially designed airborne tape recorder (Fig.5) (8 and 9) and were subsequently transposed by computer into ten second values compatible with the data from the simulator runs.

RESULTS

In analysing the data it was considered to be of primary importance to determine whether the resting values obtained before each of the experimental runs could be taken to represent a consistent base level from which to assess response during the task conditions. For these levels to be acceptable as a basis of comparison it was required that there should be little variation in the level of activity of a given variable, both within and between subjects, over the three resting periods.

The non-parametric Friedman analysis of variance, as described by Siegel (10) was therefore applied to the subjects' mean levels for each of the three resting periods, and showed no significant difference in any of the three variables (TABLE I). This showed that the group resting level was consistent for all three variables.

The subjects were then ranked according to the magnitude of their activity levels within each resting period, and for each variable the rankings in the three periods were compared by Kendall's test for concordance. This test showed significant concordance ($p = 0.05$) in the ranking of subjects' mean heart rate and mean respiratory rate, but no significant concordance in mean skin resistance levels (TABLE II).

TABLE I
Friedmans Analysis of Variance by Ranks
Pre-Condition Mean Resting Levels

	(a) HEART RATE			(b) RESPIRATORY RATE			(c) SKIN RESISTANCE		
	Before			Before			Before		
	FLY	MOV	FIX	FLY	MOV	FIX	FLY	MOV	FIX
S. 1	3	1	2	3	1	2	3	2	1
S. 2	3	2	1	2	1	3	1	3	2
S. 3	1	3	2	1	3	2	1	3	2
S. 4	3	2	1	2.5	2.5	1	2	1	3
S. 5	1	2	3	1	3	2	2	1	3
S. 6	2	1	3	1	3	2	2	3	1
S. 7	3	2	1	1	3	2	2	3	1
S. 8	3	1	2	3	2	1	3	2	1
S. 9	2	1	3	1	3	2	3	1	2
Rj	21	15	18	15.5	20.5	18.0	19	21	14
	$\Sigma(Rj)^2 = 990$ NS			$\Sigma(Rj)^2 = 984$ NS			$\Sigma(Rj)^2 = 998$ NS		

TABLE II
Rank Test for Concordance (Kendall)
Subject Pre-Condition Mean Resting Levels

	(a) MEAN HEART RATE					(b) MEAN RESPIRATORY RATE				
	Before					Before				
	FLY	MOV	FIX	Rj	Rj - \bar{Rj}	FLY	MOV	FIX	Rj	Rj - \bar{Rj}
S. 1	9	9	9	27	12	6	5	5.5	16.5	1.5
S. 2	3	3	2	8	-7	2	2	2	6	-9
S. 3	6	6	8	20	5	5	6	5.5	16.5	1.5
S. 4	7	7	6	20	5	7	7	8	22	7
S. 5	2	5	3	10	-5	8	8	7	23	8
S. 6	1	1	1	3	-12	3	3	33	9	-6
S. 7	8	8	7	23	8	4	4	4	12	-3
S. 8	5	4	5	14	-1	9	9	9	27	12
S. 9	4	2	4	10	-5	1	1	1	3	-12
	$\Sigma(Rj - 15)^2 = 502$					$\Sigma(Rj - 15)^2 = 531.5$				
	W = 0.929 p = 0.01					W = 0.984 p = 0.01				

	(c) MEAN SKIN RESISTANCE				
	Before				
	FLY	MOV	FIX	Rj	Rj - \bar{Rj}
S. 1	5	2	1	8	-7
S. 2	3	9	9	21	6
S. 3	2	3	5	10	-5
S. 4	6	7	2	15	0
S. 5	1	1	3	5	-10
S. 6	7	5	4	16	1
S. 7	4	6	6	16	1
S. 8	9	8	7	24	9
S. 9	8	4	8	20	5

$\Sigma(Rj - 15)^2 = 318$
W = 0.588 Not Significant

These findings prompted an examination of the original data which showed that, as had been expected from previous observations, the heart and respiratory rates had settled to a fairly steady level by the last five minutes of the resting period (during which the resting values were recorded), whereas the skin resistance in most cases continued to drift upwards throughout the resting period. It was also observed that although the individual resting levels of heart and respiratory rate were quite consistent there was a larger variation of these levels between subjects than had been expected (Fig. 6).

It was therefore decided that the resting heart and respiratory rates found for each subject, on each day, provided a sensible baseline for comparison against that subject's task responses on that day. However, it was clear that it would be inaccurate to combine these resting values into one standard level for each variable. It was also decided that the mean value of skin resistance found during the resting period could not be taken as a reference level and that without such a reference a comparison of mean skin resistance values in response to the task could not be undertaken.

As it was believed that the skin resistance changes did contain useful information, an alternative method of handling this variable was required. A method appropriate to the form of the data had already been described (11) and was therefore applied. This method consisted of summing all the negative going changes between consecutive ten second samples in the period under consideration, and treating the mean negative change per ten seconds as an index of activity for that period. A Friedman analysis of this index showed no significant difference between resting periods, and although concordance between subjects' rankings on all three days did not reach a significant level ($W = 0.5$), there was, as is shown below, a significant correlation between the resting and working ranks in two of the three conditions, which supported the belief that the resting levels of this derived measure could reasonably be used as a baseline for comparison of the working levels. This measure, which was referred to as Skin Resistance Activity, was therefore substituted for mean skin resistance as a basis for all further analysis of this variable.

A study of the relationship between the subject activity levels in the resting and task situations was now undertaken by the use of Spearman's rank correlation coefficient. The first relationships studied were those between the rankings of subject levels in the different resting periods (TABLE IIIa). Significant positive correlations were shown to occur within each variable where indicated by the earlier tests for concordance, but there were no significant correlations between the different variables. Thus for example, the subject with the lowest resting heart rate tended to have a consistently low resting heart rate but did not show the lowest respiratory rate or the lowest skin resistance activity.

The next set of relationships examined was that between the rankings of the resting levels and of the corresponding overall working levels. These showed positive correlations within each variable (TABLE IIIb) and several of these reached a significant level, indicating a tendency for the rankings to remain constant in different conditions. In other words the subject who showed the highest resting level for a variable tended to show the highest working level although the mean level might have changed.

A comparison of the group mean resting and working levels (TABLE IV) showed that the changes produced were not large and it was therefore not surprising to find that, on ranking the subjects' overall levels in the three working conditions, (i.e., Flying,

Moving Simulator and Fixed Simulator), and submitting these rankings to Friedman's Analysis of Variance, no significant difference could be shown between conditions for any of the three variables.

TABLE III

Rank Correlations (Spearman)

a. Between Resting Levels

	HEART RATE		RESPIRATORY RATE		S. R. ACTIVITY	
	Moving	Fixed	Moving	Fixed	Moving	Fixed
Flying	+0.98**	+0.94**	+0.98**	+0.98**	+0.34	+0.60*
Moving	-	+0.86**	-	+9.98**	-	-0.15

NO SIGNIFICANT CROSS CORRELATIONS BETWEEN VARIABLES

b. Between Resting and Working Levels

	HEART RATE	RESPIRATORY RATE	S. R. ACTIVITY
Flying	+0.30	+0.50	+0.68*
Moving	+0.90**	+0.71*	+0.16
Fixed	+0.82**	+0.58	+0.80**

Significance indication

* p < 0.05 significant
 ** p < 0.01 highly significant
 *** p < 0.001 very highly significant

It was noted at this point that the mean working levels of skin resistance activity were slightly lower than the mean levels found for the supposed resting periods. In order to investigate this phenomenon a plot was made of the group mean activity levels for each task period under the three conditions (Fig. 7). In the case of the flight and moving simulator conditions this plot showed a clear tendency for activity during the manoeuvre periods (climbing and descending turns) to be greater than the resting activity and for the activity during the periods of straight and level "flight" to be less than resting. In the fixed simulator condition, however, there was considerably less difference, and level "flight" appeared to provoke slightly more activity than the manoeuvre.

These observations led to the conclusion that the music input during the resting period was evoking some activity and that the activity levels evoked during this period should be regarded as levels of response to a standard condition rather than as resting levels. This did not preclude their use as a basis for comparison as their consistency had already been demonstrated.

It was now clear that the investigation of the difference in level during the two tasks and the "resting" period should be extended to cover the other two variables. A value for levels during manoeuvres (mean of four periods) and level flight (mean of five periods) was calculated for each subject variable and these values and the

appropriate resting values were compared, by Friedman's analysis of variance, for each of the three conditions (TABLE V). It was found that there was a consistent tendency for manoeuvres to provide a higher level than level "flight" or the "resting" period in the flight and moving simulator conditions. This tendency reached significance in the case of heart rate. In the fixed simulator condition no clear difference between the task levels was evident.

TABLE IV

Group Mean in Resting and Working Levels

VARIABLE	CONDITION	MEAN RESTING	MEAN WORKING	CHANGE
Heart	Flying	72.96	78.72	+5.76
Rate	Moving	75.84	78.36	+2.52
Bt/min	Fixed	76.74	80.70	+3.96
Resp	Flying	14.16	15.68	+1.52
Rate	Moving	14.22	14.82	+0.60
Br/min	Fixed	14.52	15.24	+0.72
SR	Flying	4.68	4.14	-0.54
Activity	Moving	3.42	3.36	-0.06
-KΩ/min	Fixed	3.48	3.78	-0.06

Subtraction of the appropriate resting value from each subject's mean value for manoeuvres and for level flight gave a comparative measure of response to the tasks. The relationship between these subject responses to the two types of task was investigated by means of Spearman's Rank Correlation (TABLE VIa) and a consistent, and frequently significant, positive correlation was found within variables but, as before, there was no evidence of correlation between variables. Thus the subject whose heart rate increased most during manoeuvres also tended to show the greatest increase during straight and level flight but did not tend to show the greatest concomitant increase in respiratory rate or skin resistance activity. This suggested that these variables could be treated as statistically independent.

Another interesting relationship found was that between the resting levels and the disturbances from those levels produced by the tasks (TABLE VIb). Here a preponderance of negative correlations was found, indicating that the subject with the highest resting level of a given variable tended to show the smallest change from that level in the task situation. (These findings were in agreement with Wilder's Law of Initial Values (12), which, simply stated, says that the magnitude of an autonomic nervous system response can be considered to be an inverse function of the pre-stimulus level.)

Next a set of overall working responses to each condition, for each subject and variable, was calculated by subtraction of each resting level from its corresponding overall mean working level. Each subject's responses in a given variable were ranked for the three working conditions and submitted to Friedman's Analysis of Variance. As was the case when working levels were analysed in this manner, no significant difference could be shown between conditions for any of the three variables.

TABLE V

Comparison by Ranks of Activity Levels During Tasks
and the Resting Period

FLIGHT

SUBJECT	HEART RATE			RESPIRATORY RATE			S. R. ACTIVITY		
	MAN	LEV	REST	MAN	LEV	REST	MAN	LEV	REST
1	3	2	1	3	2	1	2	1	3
2	3	1	2	1	2	3	3	2	1
3	3	2	1	3	2	1	2	1	3
4	3	2	1	3	2	1	2	3	1
5	3	2	1	3	2	1	2	1	3
6	2	1	3	2	3	1	2	1	3
7	3	2	1	3	2	1	3	2	1
8	3	2	1	3	2	1	3	1.5	1.5
9	3	2	1	2	1	3	3	2	1
	26	16	12	23	18	13	22	14.5	17.5
	$(R_j)^2 = 1086$ p = 0.01			$(R_j)^2 = 1022$ p = 0.07			$(R_j)^2 = 1000.5$ N. S.		

MOVING

SUBJECT	HEART RATE			RESPIRATORY RATE			S. R. ACTIVITY		
	MAN	LEV	REST	MAN	LEV	REST	MAN	LEV	REST
1	3	2	1	3	2	1	3	1	2
2	3	2	1	1	2	3	3	1	2
3	2	3	1	3	1	2	2	1	3
4	3	2	1	2	1	3	3	2	1
5	3	2	1	3	1	2	3	1	2
6	2	3	1	2	3	1	1	2	3
7	2	3	1	3	2	1	2	1	3
8	3	1	2	3	2	1	2	3	1
9	1	2	3	2	1	3	2	1	3
	22	20	12	22	15	17	21	13	20
	$(R_j)^2 = 1028$ p = 0.05			$(R_j)^2 = 998$ N. S.			$(R_j)^2 = 1010$ N. S.		

FIXED

SUBJECT	HEART RATE			RESPIRATORY RATE			S. R. ACTIVITY		
	MAN	LEV	REST	MAN	LEV	REST	MAN	LEV	REST
1	3	2	1	3	2	1	1	2	3
2	3	1	2	1	2	3	1	3	2
3	1	2.5	2.5	3	2	1	3	2	1
4	2	3	1	1	2	3	3	2	1
5	2	3	1	3	1	2	3	2	1
6	2	3	1	3	2	1	1	3	2
7	1	2	3	3	2	1	2	3	1
8	3	1	2	3	1	2	2	1	3
9	2	3	1	3	1	2	1	2	3
	19	20.5	14.5	23	15	16	17	20	17
	$(R_j)^2 = 991.5$ N. S.			$(R_j)^2 = 1010$ N. S.			$(R_j)^2 = 978$ N. S.		

TABLE VI

Rank Correlations (Spearman)

a. Between Disturbances from Resting During Manoeuvres and During Level Flight

	HEART RATE	RESP RATE	S. R. ACTIVITY
Flying	+0.98 ^{**}	+0.37	+0.70 [*]
Moving	+0.72 [*]	+0.97 ^{**}	+0.80 ^{**}
Fixed	+0.57	+0.97	+0.63 [*]

b. Between Resting Levels and Disturbances from Resting During Tasks

	HEART RATE		RESP RATE		S. R. ACTIVITY	
	Manoeuvre	Level	Manoeuvre	Level	Manoeuvre	Level
Flying	-0.75 [*]	-0.73 [*]	-0.56	-0.23	-0.65 [*]	-0.83 ^{**}
Moving	-0.55	-0.37	-0.40	-0.10	-0.78 [*]	-0.93 ^{**}
Fixed	-0.17	-0.33	+0.04	+0.13	-0.87 ^{**}	-0.71 [*]

After the individual variables had been examined in this manner and had failed to distinguish between the experimental conditions, it was considered that an attempt should be made to combine the responses from the three separate variables in order to obtain one overall measure of subject response. The absence of correlations between the responses in the different variables appeared to agree with Schnore's observation (14) that the ratio between the magnitude of responses in different variables tended to vary markedly between subjects, and it was thought that combination of a subject's responses might allow more balanced assessment of his reaction to the situation.

A method of combination by ranks was developed. For each subject the responses shown by the three variables were ranked against the three experimental conditions and the total of ranks for each condition was found. This set of totals was then used as the basis for re-ranking on a simple 1,2,3 scale (TABLE VII). The resulting set of re-rankings from the nine subjects was then submitted to Friedman Analysis in the usual way (TABLE VIII). The rank totals indicated an increase of response from the fixed simulator condition through moving simulation to the flight condition but this trend did not reach significance. Separate sets of combined responses for the manoeuvre and low level flight tasks were then prepared and analysed in the same manner (TABLE IX). These showed that, as might have been expected, during manoeuvres subjects showed a greater response to the flight condition than to either of the simulator conditions ($p = 0.05$). However, no significant difference appeared between responses to the level flight task and there was an indication that this evoked a response in the flight and fixed simulator conditions greater than it evoked in the moving simulator.

TABLE VII

Combination by Ranks. Example

SUBJECT 1	Fly	Mov	Fix
Heart Rate	3	1	2
Respiratory Rate	3	1.5	1.5
S. R. Activity	2	3	1
Total	8	5.5	4.5
Re-Ranking	3	2	1

TABLE VIII

Combined Responses over all Task Periods

Heart Rate, Respiration Rate and Skin Resistance Activity
Combined for each Subject

	Fly	Mov	Fix	
SUBJECT 1	3	2	3	
2	3	2	1	
3	3	1	2	
4	3	2	1	$\Sigma(R_j)^2 = 991.5$
5	1	3	2	
6	1	3	2	Not Significant
7	2.5	1	2.5	
8	3	2	1	
9	2	1	3	
Rj	21.5	17	15.5	

TABLE IX

Combined Mean Task Responses

Heart Rate, Respiration Rate and Skin Resistance Activity
Combined for each Subject

(a) MANOEUVRES ONLY				(b) STRAIGHT AND LEVEL ONLY			
	FLY	MOV	FIX		FLY	MOV	FIX
SUBJECT 1	2	3	1	SUBJECT 1	1	2	3
2	3	2	1	2	3	2	1
3	2	1	3	3	2	1	3
4	3	2	1	4	3	1	2
5	3	2	1	5	3	1	2
6	3	1	2	6	1	3	2
7	2	1	3	7	2	1	3
8	3	2	1	8	2	1	3
9	3	1	2	9	2.5	1	2.5
Rj	24	15	15	Rj	19.5	15	19.5
$\Sigma(R_j)^2 = 1026$		$p = 0.05^*$		$\Sigma(R_j)^2 = 985.5$		N.S.	

In order to investigate this apparent anomaly a set of combined rank tables, derived from rankings of the mean levels of the three variables during the two tasks and the resting period was analysed. There were three such tables, each referring to one experimental condition (TABLE X). These showed that under flight and moving simulator conditions, the levels during the manoeuvre task were significantly greater than the levels during the level flight task and the resting period. On the other hand no significant difference could be demonstrated by Friedman's analysis between levels in the fixed simulator condition. A simple binomial test showed however, that the manoeuvre levels were significantly higher than the resting levels ($p = 0.035$) and were not significantly different from those found during the level flight task in this condition.

TABLE X
Combined Ranks of Mean Levels for Separate Tasks

SUBJECT	(a) FLIGHT			(b) MOVING SIM			(c) FIXED SIM		
	MAN	LEV	REST	MAN	LEV	REST	MAN	LEV	REST
1	3	1.5	1.5	3	2	1	3	2	1
2	3	1	2	3	1	2	1	2	3
3	3	1.5	1.5	3	1	2	3	2	1
4	3	2	1	3	1.5	1.5	2	3	1
5	3	1.5	1.5	3	1	2	3	2	1
6	2	1	3	1.5	3	1.5	2	3	1
7	3	2	1	3	2	1	2	3	1
8	3	2	1	3	2	1	3	1	2
9	3	1.5	1.5	2	1	3	2	2	2
	26	14	14	24.5	14.5	15	21	20	13
	$(R_j)^2 = 1068$ $p = 0.01$			$(R_j)^2 = 1035.5$ $p = 0.05$			$(R_j)^2 = 1010$ N.S.		

CONCLUSIONS

The use of a standard condition rather than absolute resting appears to offer a practical baseline for comparison of physiological measures.

With the three measures used subjects tend to retain their rank relationships to each other despite changes in working levels. The retention of these relationships in a set of measurements offers a practical indication of the coherence of the data.

The findings support the view that there tends to be an inverse relationship between the magnitude of the resting levels and the magnitude of the changes produced by a specific stress.

It is practical to combine the responses shown by several variables into a single subject response and it is considered that, if the measures are tested for coherence and independence in the manner described, the more variables are combined, the more sensitive the indication of the subjects overall response.

The addition of pitch motion to the simulator does increase the realism of simulation, but this is achieved at least as much by the decrease in the difficulty of straight and level flight as by an increase in the difficulty of performing manoeuvres. It is presumed that the higher stress level during straight and level "flight" in the fixed simulator is due to the absence of helpful information from kinaesthetic cues which may be present in the other experimental conditions.

Subjects appear to react more strongly to differences in the difficulty of the task than to changes in experimental conditions but it is clear that multi-variable physiological recording offers an effective method of comparison between simulated and real flight conditions.

ACKNOWLEDGMENTS

The Authors wish to acknowledge their indebtedness to Mr R.Poulter, for his thorough preparation and efficient operation of the Institute's Flight Simulator facility during this experiment.

Thanks are also due to Mr E.Smart for his supervision of the airborne recording equipment, and to Miss J.Rapson for her assistance both in the experiment and in processing the data.

We are grateful to the Institute's Statistical Section, under Miss H.Ferres, for their advice, and for the provision of computer facilities.

REFERENCES (PHYSIOLOGICAL MEASURES)

1. REID, G.H. & BURTON, H.L. Psychomotor responses in relation to flying, Proc. R. Soc. Med. 1923-24, 17(3) 43-53.
2. FRASER, T.M. (1966). Philosophy of simulation in a man - machine space mission system. NASA Special Publication 102.
3. GEMELLI, A. (1917). Sull'applicazione dei metodi psico-fisici all'esame dei candidati all'aviazione militare. RIV. Psicol. 13 157-190.
4. BENSON, A.J. & ROLFE, J.M. (1966). The use of psychophysiological measures in the assessment of operator effort. AGARD.
5. O'CONNOR, P.D.T. (1967). A low cost one degree of freedom flight motion simulator. IAM Tech Memo No.301.
6. HAMMERTON-FRASER, A.M. (1967). A surface electrode for electrocardiography and electromyography. IAM Tech Memo No.303.
7. HAMMERTON-FRASER, A.M. (1967). A digital system for multivariable physiological recording. IAM Tech Memo No.308.
8. SMART, E.R. (1967). A fourteen channel airborne tape recorder. IAM Tech Memo No.290.
9. O'CONNOR, P.D.T. (1967). Experimental support installations in Hunter T7. IAM Tech Memo No.296.
10. SIEGEL, S. Non-parametric statistics for the behavioural sciences. McGraw Hill, New York.
11. HAMMERTON-FRASER, A.M. & MORGAN, G.F. (in preparation). An index of mental activity from digital sampling of the galvanic skin response (IAM Sc Memo No.82).

12. WILDER, J. (1957). Law of Initial Values in Neurology and Psychiatry. Facts and Problems. J. nerv. ment. DIS. 125, 73-86.
13. SCHNORE, M.M. (1959). Individual patterns of physiological activity as a function of task differences and degree of arousal. J. Exp. Psychol. 58, No.2, 117-128.

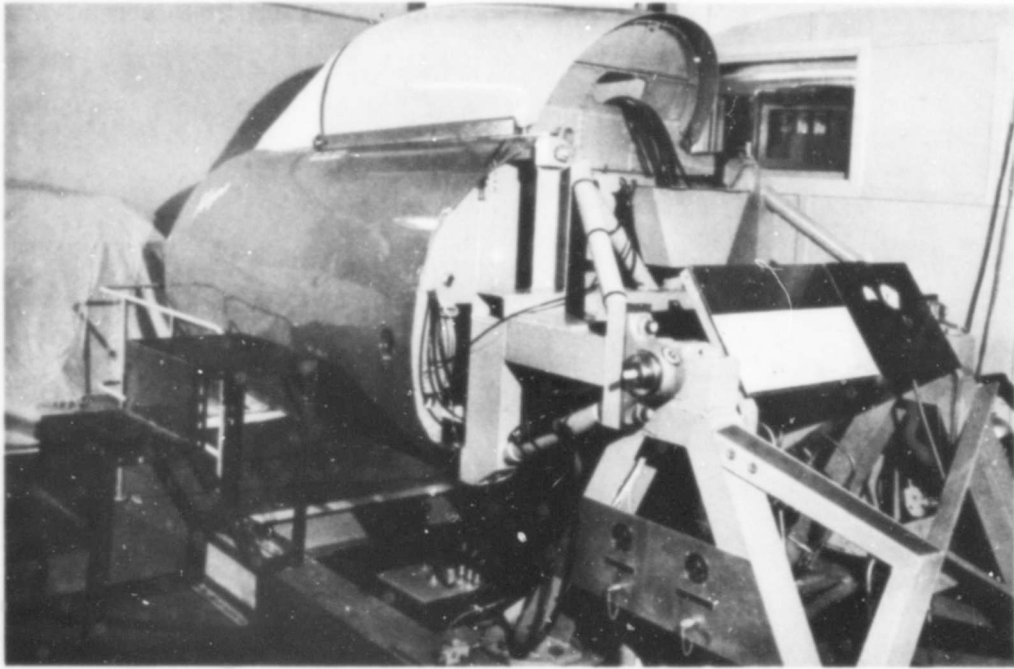

Fig. 1 The Flight Skills Laboratory simulator



Fig. 2 The Institute's Hunter T7



Fig. 3 The "Remake" electrode

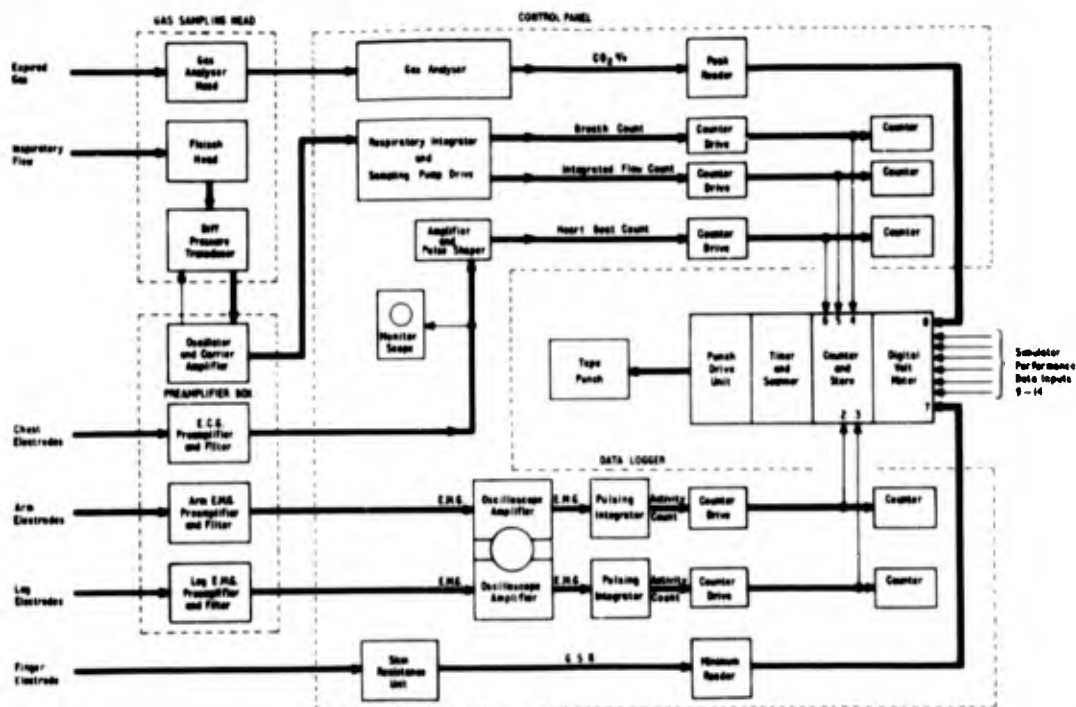

Fig. 4 Block diagram of the complete multivariable physiological recording system

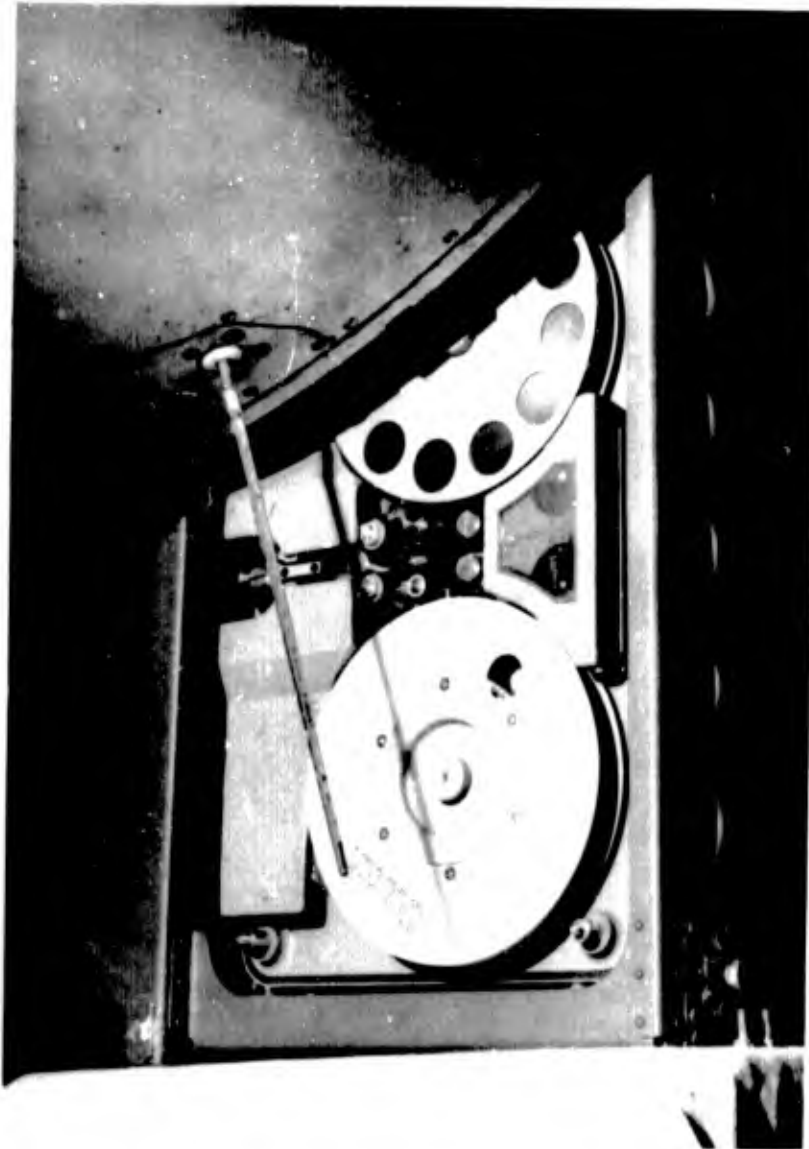

Fig.5 The airborne tape recorder about to be fitted into the Hunter

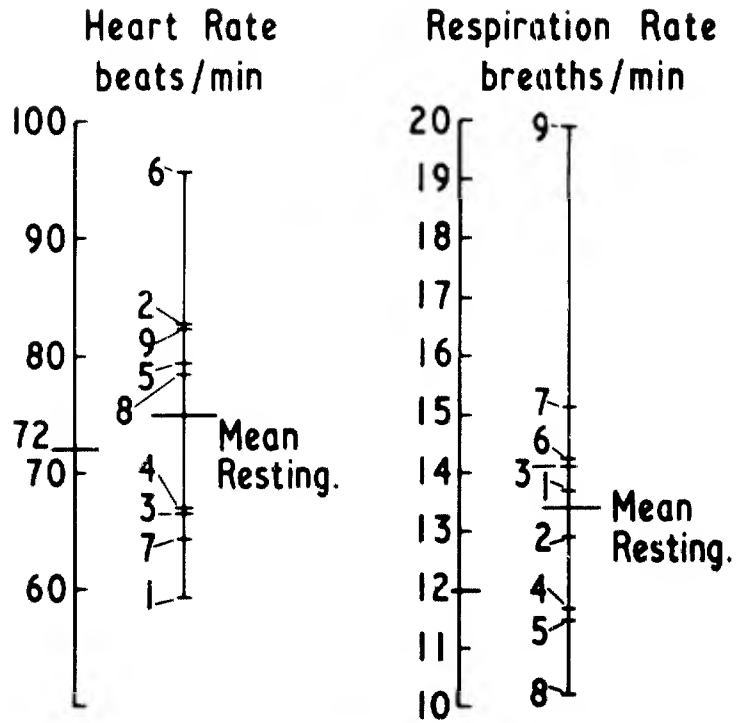

Fig.6 Mean resting levels

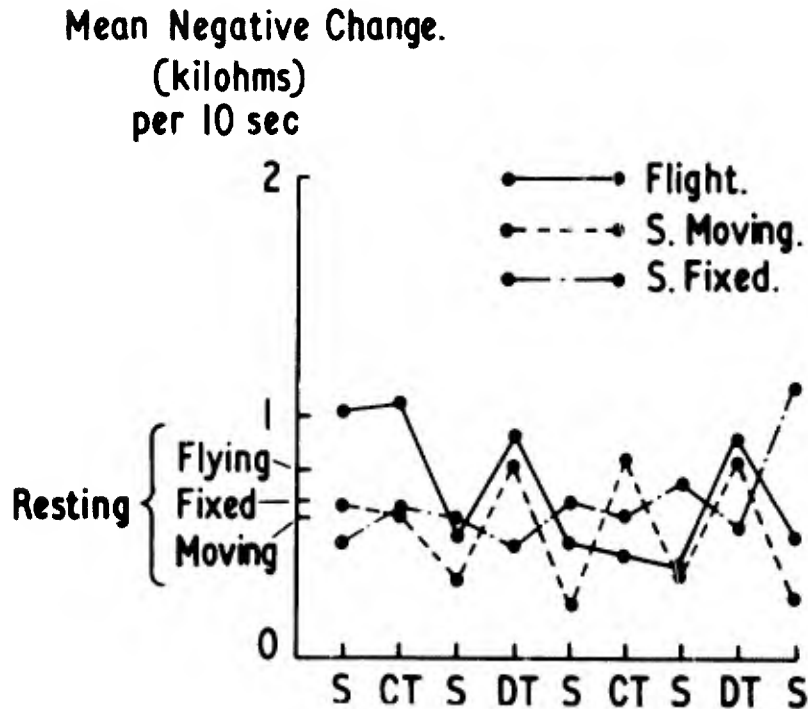

Fig.7 Galvanic skin response activity index

APPENDIX A

Flight/Simulator Comparison of
Physiological Measures

1. Flight Profile. To accord with the limitations of the simulator system in yaw the following flight profile was employed for the airborne phase of the experiment:-
 - a. Subject takes off and climbs at 370 knots to FL 80 and levels off.
 - b. Experimenter takes over control for 5 minutes with subject passive for "base line" measures.
 - c. Subject takes over and flies straight and level at 300 knots and FL 80 for 1 minute.
 - d. On instruction the subject carries out a climbing turn to the left at 300 knots and 3000 ft/min, climbing 5000 ft and turning (Rate $\frac{1}{2}$) through 150° . Subject calls completion of manoeuvre when settled and operates stick camera button.
 - e. Subject flies straight and level at 300 knots and FL 130 for 1 minute.
 - f. On instruction the subject carries out a descending turn to the right at 300 knots (with 23° flap) and 3000 ft/min, descending 5000 ft and turning through 150° . Subject calls completion of manoeuvre when settled.
 - g. Subject flies straight and level at 300 knots and FL 80 for 1 minute.
 - h. Subject repeats sequence d, e, f and g.
 - j. Experimenter takes over control for 3 minutes with subject passive for further "base line" recordings.
 - k. Subject carries out recovery to Farnborough.

METHODS USED AT AMRD IN THE STUDY OF NORMAL SLEEP
AND DRUG-INDUCED SLEEP ON A VISUAL ALERTNESS TEST

R. D. Squires, M.D. and W. C. Sipple

U. S. Naval Air Development Center
Aerospace Medical Research Department
Johnsville, Warminster, Pa.
U S A

Summary

Methods used in an ongoing study of human sleep are briefly described. The ultimate aim of this study is to induce normal, restful sleep by pharmacological means with minimal undesired side effects. The methods used are designed to test the restorative effect of sleep and its relationship to time spent in the various stages or levels of sleep to the restorative effect.

We have recently undertaken a study of sleep with special regard to the question of whether anything like normal restful sleep can be induced by pharmacological means. In order to compare normal with drug induced sleep we felt that we must obtain objective as well as subjective data.

Amongst the very first observations on the electroencephalogram (EEG) was the striking relationship of the alpha frequencies to the processes of attention and its sensitivity to variations in the level of awareness in the waking state. This is especially true of visual attention (1). The EEG is also probably the best single objective indicator of sleep and wakefulness. The transition from wakefulness to sleep is characterized by changes in frequency distribution of the EEG. The low voltage, rapid, irregular brain waves of the waking state progressively give way to the higher voltage, slower, more regular waves of sleep (2). This shift can readily be displayed by frequency analysis and provides a basis for dividing sleep into levels or stages (3). We sometimes hear the remark, "I slept badly last night". A bad night's sleep often occurs during or following periods of emotional stress when despite a sense of fatigue we had difficulty in falling asleep. This can sometimes be attributed at least in part to having taken certain sleep inducing drugs. This evaluation is based not only on our estimate of the duration but also to rather vague, unpleasant recollections of our repose. What we are most acutely aware of, however, is the lack of the anticipated restorative effects of sleep which leave us with a mixture of feelings, including varying degrees of depression, agitation, irritability, confusion and reduced ability to sustain attention, e.g. visual attention.

Since the above mentioned effects of a bad night's sleep are similar to total sleep deprivation we chose first to test the effects of 36 hours of sleep deprivation on ability to suppress the alpha rhythm, i.e. visual alertness or attention. The details of this method have been reported elsewhere (4), and is briefly described as follows: The subject is first instructed to close his eyes and relax as completely as possible for a sixty-second interval. Immediately following this interval, he is told to open his eyes and, for another sixty-second interval, to stare as intently as possible at an oscilloscope on which is displayed the D. C. output of the alpha band of the frequency analyzer. The greater the effort expended by the subject in concentrating on his alpha trace, the greater the degree of alpha suppression and the lower the trace becomes. The technique of using an oscilloscope provides a feedback loop to the subject, permitting him to evaluate his own "visual concentration level", and it was found, generally induces a greater degree of alpha suppression than intent concentration on, for example, some static target.

This entire routine consists of twenty consecutive sixty-second intervals with alternate intervals of the relaxing and staring procedure described previously. Figure 1 shows a typical continuous output of the frequency analyzer before being fed into the computer for calculation of the average values. Figure 2 was constructed from the average output level as computed by the analog computer at the end of each sixty-second interval only so that in this graph, information about phase relationships during each interval is lost, although the actual computer output showed continuous average values.

The upper part of Table 1 illustrates the ability of 4 subjects to suppress their alpha frequencies before, after and following recovery from 36 hours of sleep deprivation. The average reduction in alpha frequencies was 41% before, 25% after and 48% following recovery. The lower part of Table 1 illustrates the ratio of change in certain plasma phospholipids before, after and following recovery from 36 hours of sleep deprivation. Changes in plasma phospholipids have reported to be modified by various forms of stress (5). The phosphatidyl glycerol (G) to cardiolipin (C) ratio virtually doubled after 36 hours of sleep deprivation and decreased after recovery. These tests can be used in the objective evaluation of the restorative value of sleep.

Figure 3 illustrates how frequency analysis can be used to indicate periods of wakefulness. The frequency analyzer was used to extract "4" frequency bands from the EEG; Beta 20-25 cps, Alpha 8-15 cps, Theta 6-7 cps, and Delta 1-4 cps. The subject from whom this record was taken had had little sleep the night before and had worked until he was permitted to fall asleep in the late afternoon. At the beginning of this record his eyes had been closed for about 15 minutes. The decreasing beta and alpha activity, as well as the increasing theta and delta activity, indicated the subject was falling asleep. Approximately 9 minutes from the beginning of this record the subject stated that he had been suddenly aroused by a frightening dream. Whereupon the beta and alpha activity increased while theta and delta activity decreased. The EEG changes, however, indicated the subject again promptly fell asleep. One-half hour later he stated that he was fully awakened from a sound sleep by a sudden loud noise and the EEG frequency changes again indicated arousal. When additional channels of information are added such as an oculonystagmogram and an electromyogram the various stages or levels of sleep can be identified and their duration estimated. Dr. Oleynik will further describe in his paper how this information is being used.

References

1. Jasper, H. H. Functional properties of the thalamic reticular system. In: Brain Mechanisms and Consciousness, a Symposium. E. D. Adrian, F. Bremer, and H. H. Jasper (eds.). Charles C. Thomas, Springfield, Ill., 1954, pp. 374-401.
2. Brazier, M. A. B. The Electrical Activity of the Nervous System. The Macmillan Company, New York, 1953.
3. Squires, R. D. The electroencephalogram as a physiological criterion of performance. Aerospace Medical Research Department, U. S. Naval Air Development Center, Johnsville, Warminster, Pa., presented at the 23rd Aerospace Medical Panel Meeting, Toronto, Ontario, Canada, 7-9 September, 1966.
4. Bergey, G. E., W. C. Sipple, W. A. Hamilton, R. D. Squires. A technique for determining an index of visual alertness from the electroencephalogram. Aerospace Medical Research Department, U.S. Naval Air Development Center, Johnsville, Warminster, Pa., Report No. NADC-MR-6618, 1967.
5. Polis, B. D., and J. J. Martorano, H. P. Schwarz, E. Polis, and L. Dreisbach. Aerospace Medical Research Department and Department of Biochemistry, Philadelphia General Hospital, Philadelphia, Pa., presented at the 23rd Aerospace Medical Panel Meeting, Toronto, Ontario, Canada, 7-9 September, 1966.

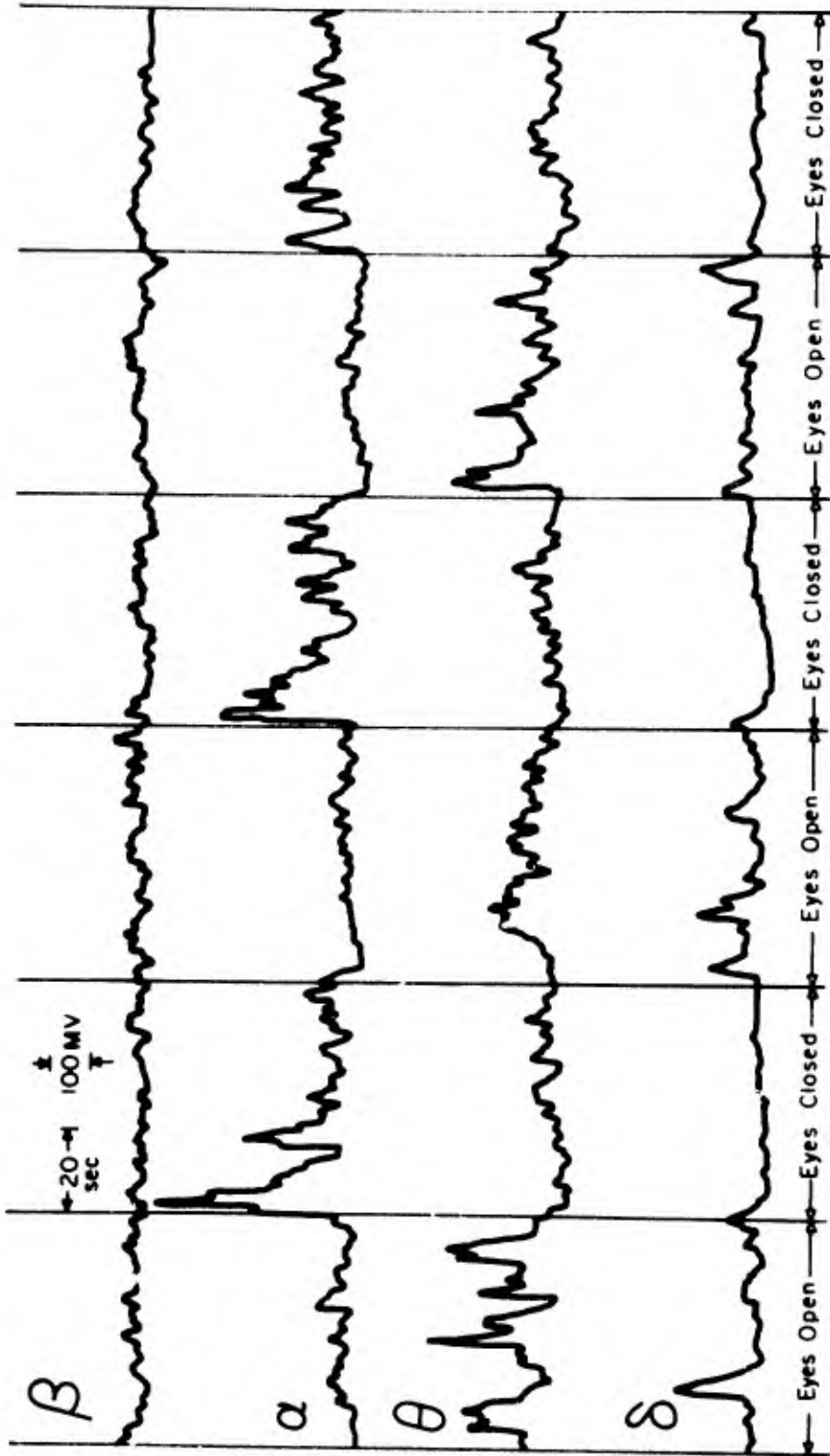

1. Chart recording showing continuous monitoring of the four output channels of the analyzer during part of the eyes open/closed routine as described in the text.

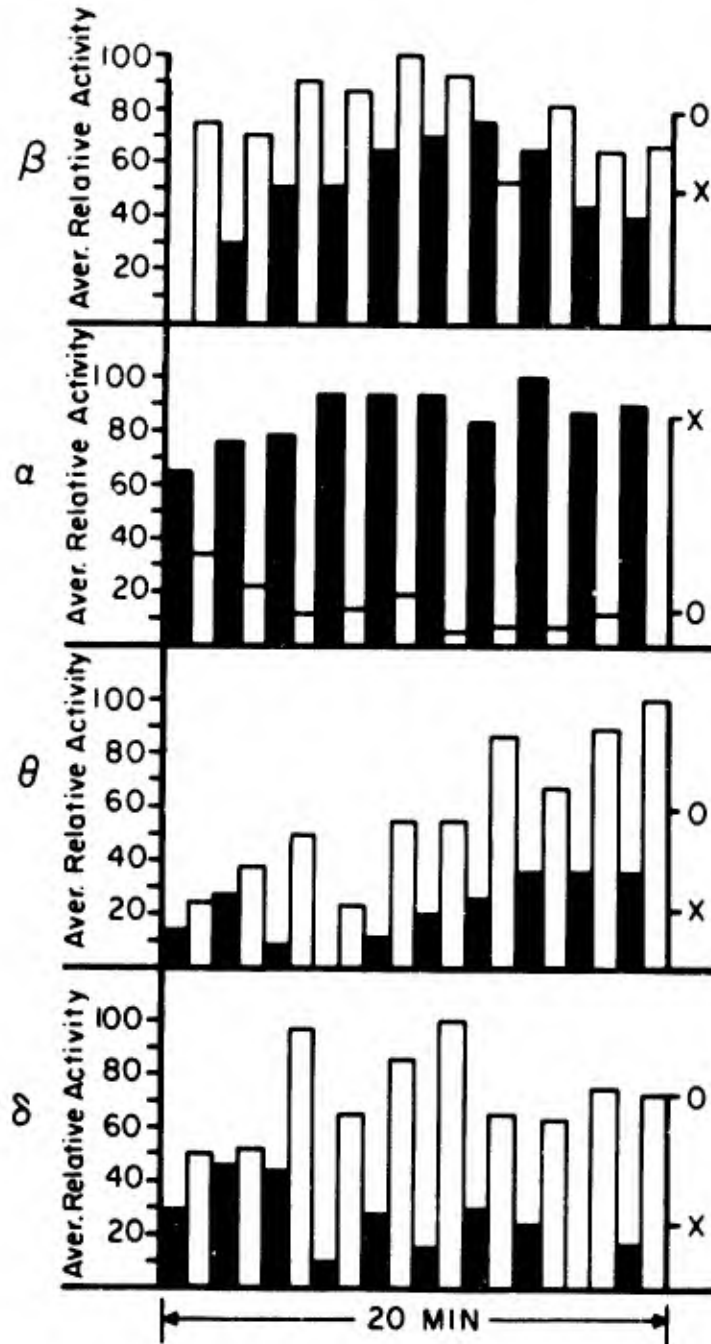

2. Average value of each of the four outputs of the EEG frequency analyzer at the end of twenty 60-second intervals as described in the text.

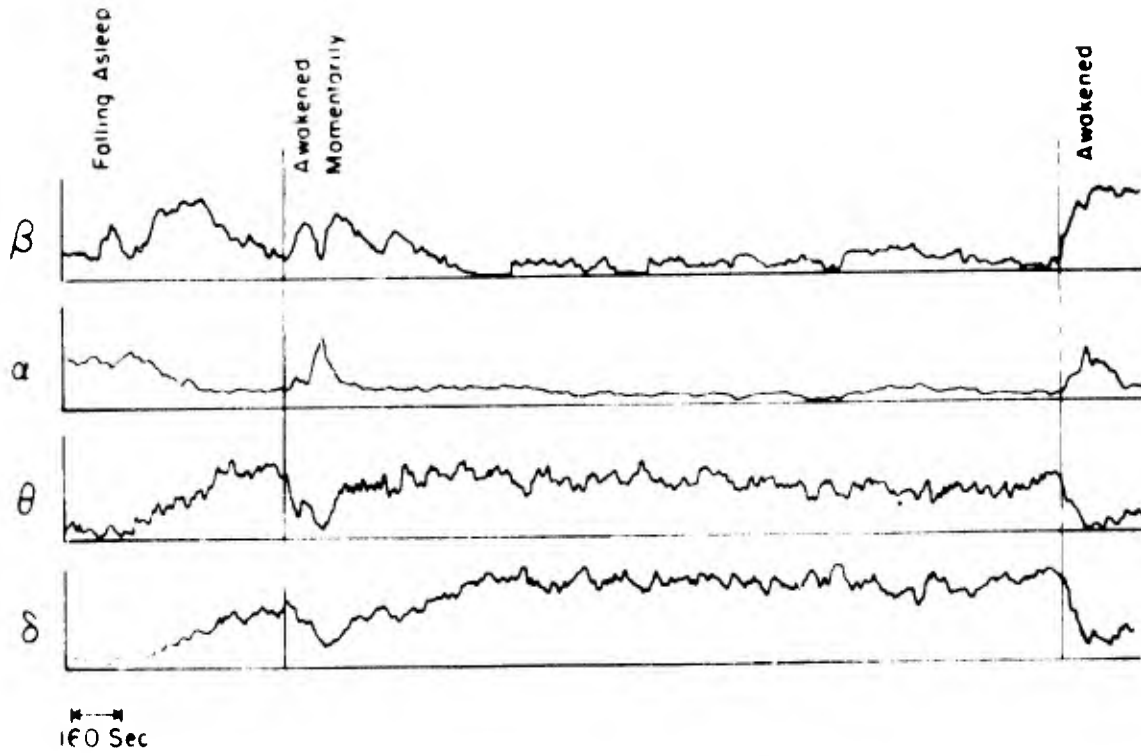

3. Frequency analysis of a period of sleep as described in the text.

Subject	Before	After	Recovery
1	62	41	51
2	15	7	38
3	27	8	40
4	61	45	61
Mean	41.2	25.2	47.5
G/C Ratio			
1	1.78	3.46	1.22
2	1.47	2.94	1.08
3	1.54	2.68	1.32
4	1.33	2.76	1.30
Mean	1.53	2.96	1.23

Table 1. Sleep Deprivation Percent Reduction in Alpha.

THE EFFECTS OF NORMAL SLEEP AND DRUG-INDUCED SLEEP
ON A VISUAL ALERTNESS TEST

R.J. Oleynik, M.D. and R.D. Squires, M.D.

U. S. Naval Air Development Center
Aerospace Medical Research Department
Johnsville, Warminster, Pa.
U S A

Summary

Restful sleep is often difficult to obtain under a number of stressful situations such as rapid time-zone changes, various fatigue states and chronic drug ingestion. Recent investigations have been directed towards elucidating the relative importance of two distinct phases of sleep, the rapid-eye-movement phase (REM) and the non-rapid-eye-movement phase (NREM), in obtaining restful sleep. It has been postulated that normal, restful sleep must contain a certain proportion of REM/NREM. Deprivation of REM sleep appears to lead to behavioral changes similar to those characterizing total sleep deprivation, namely, increased irritability, depression and inability to concentrate. Volunteer subjects were instrumented for biomedical monitoring and asked to sleep after ingesting one of various sedative-hypnotic drugs. Pentobarbital decreased REM time markedly over control-placebo levels, but four other preparations had minimal or equivocal effects. Analysis of pre and post sleep visual concentration tasks (used as an objective index of alertness) is in progress.

The need for increased pharmacological knowledge and practice to maximize capabilities of pilots in sustained aerospace missions has been recognized for some time. Among the agents whose uses are anticipated in this regard are drugs modifying central nervous functions, especially the anti-motion sickness and sedation spectra. "Restful" sleep has been possible in past orbital space missions without the use of drugs, but this fact by no means precludes the use of hypnotic-sedative preparations on longer flights to ameliorate sleep disturbances, possible consequences of altered biological rhythms, and various fatigue states.

Before very recent times the role of sleep was held to be allied to the need for restitution or at least for rest. Since the demonstration that there are at least two distinct states of consciousness involved in "sleep", it is apparent that more than a simple parallelism between rest and sleep is required to elucidate the role of sleep in our biological economy. For practical purposes, it is convenient to divide sleep into two broad phases: the period accompanied by generalized muscular hypotonia but rapid eye movements (REM sleep, paradoxical sleep, rhombencephalic sleep, activated sleep, dreaming sleep, the D-state, etc) and constituting about 20% of the average night's sleep, hereafter referred to as REM; and the remainder of sleep time, hereafter referred to as NREM.

Controversy as to the relative priorities of and needs for the two major phases of sleep is far from resolution, but selective deprivation studies have brought forth some seemingly significant conclusions. Humans who have been selectively REM deprived tend to make up this deficit within certain well-defined patterns on recovery nights. Whether or not significant psychological aberrations and performance decrements are the result of chronic REM deprivation is a matter of contention, but animal studies seem to indicate definite impairment of problem-solving capabilities and other intellectual and behavioral modalities in addition to corroborating data as to the quantitative and highly specific nature of the REM deprivation-recovery phenomenon.

Although there are many situations and medications that tend to cause selective REM deprivation in humans, the role of total sleep deprivation must not be underemphasized, since the latter is probably the most common type of sleep aberration encountered, and it often involves either selective REM deprivation or alteration of the normal REM/NREM ratio that is thought by many to be a necessary component of "restful" sleep. Since inappropriate or lethargic performance secondary to sleep deprivation or sleep aberration may significantly jeopardize future aerospace and other military missions, a study evaluating various hypnotic-sedatives with respect to "quality" of sleep elicited, arousal characteristics, and psychophysiological performance was thought by us to be valuable.

We then exposed human male volunteer subjects to ingestion of various hypnotic-sedative drugs in moderate dosage (with appropriate drug controls and placebos) after which they were put to bed and monitored continuously, obtaining EEG's and oculonystagmograms. Immediately before drug ingestion and upon awakening the subjects were performance-tested using a visual concentration test developed at the U. S. Naval Air Development Center and previously described by Dr. Squires.

The expected result was to select a hypnotic-sedative drug suitable for long-term aerospace or other military missions which would fulfill the following desirable criteria: (1) elicit "restful" sleep, presumably by keeping the normal REM/NREM ratio intact, (2) permit ease of arousal at any time after drug ingestion, and (3) cause no or minimal impairment of performance at any time after taking drug.

Figure 1 shows the distribution of the percentage of REM sleep as experienced by subjects during various conditions and drug-states. A perusal of the graph demonstrates control-placebo values of about 23% (23.2) and what appears to be a significant REM decrease (13.6%) with pentobarbital, these values being rather consistent with those reported by most other investigators. The other values listed do not show significant differences from the controls, although the limited number of trials (in keeping with inherent time and space limitations) may have significant influence in this regard.

Some discussion of the reasons for selection of the drugs used in this study is appropriate. Chlordiazepoxide (dose-10mgm) is a popularly employed tranquilizer with a reputation for causing little or no performance decrement and permitting sleep comparable to the drugless state. Meprobamate (dose-400mgm) is thought by many to cause minimal alertness and performance decrements and permit sleep in mild anxiety and fatigue states, although there are conflicting reports as to its effects on REM sleep. Methaqualone (dose-150mgm) is a quinazalone hypnotic which reportedly promotes refreshing sleep (lasting 6-8 hours) characterized by normal EEG's and lack of "hangover" or toxic effects. Hydroxyzine (dose-50mgm) is an antihistamine which supposedly promotes slow-wave sleep in addition to having pronounced anti-motion sickness effects. Pentobarbital (dose-100mgm) is a very commonly used hypnotic and was thought to be a good representative of the barbiturates.

Unfortunately, time did not permit analysis of the visual concentration performance tests done before drug ingestion and upon awakening. Work of the same nature as described here is in progress. In addition to more experiments using the drugs heretofore mentioned, we are undertaking human studies using sodium gamma-hydroxybutyrate, a drug which produces a state of environmental detachment much like REM sleep, in addition to having characteristics of rapid recovery and low toxicity. The aforementioned experiments together with analysis of the performance tasks will form the basis of a more complete future report.

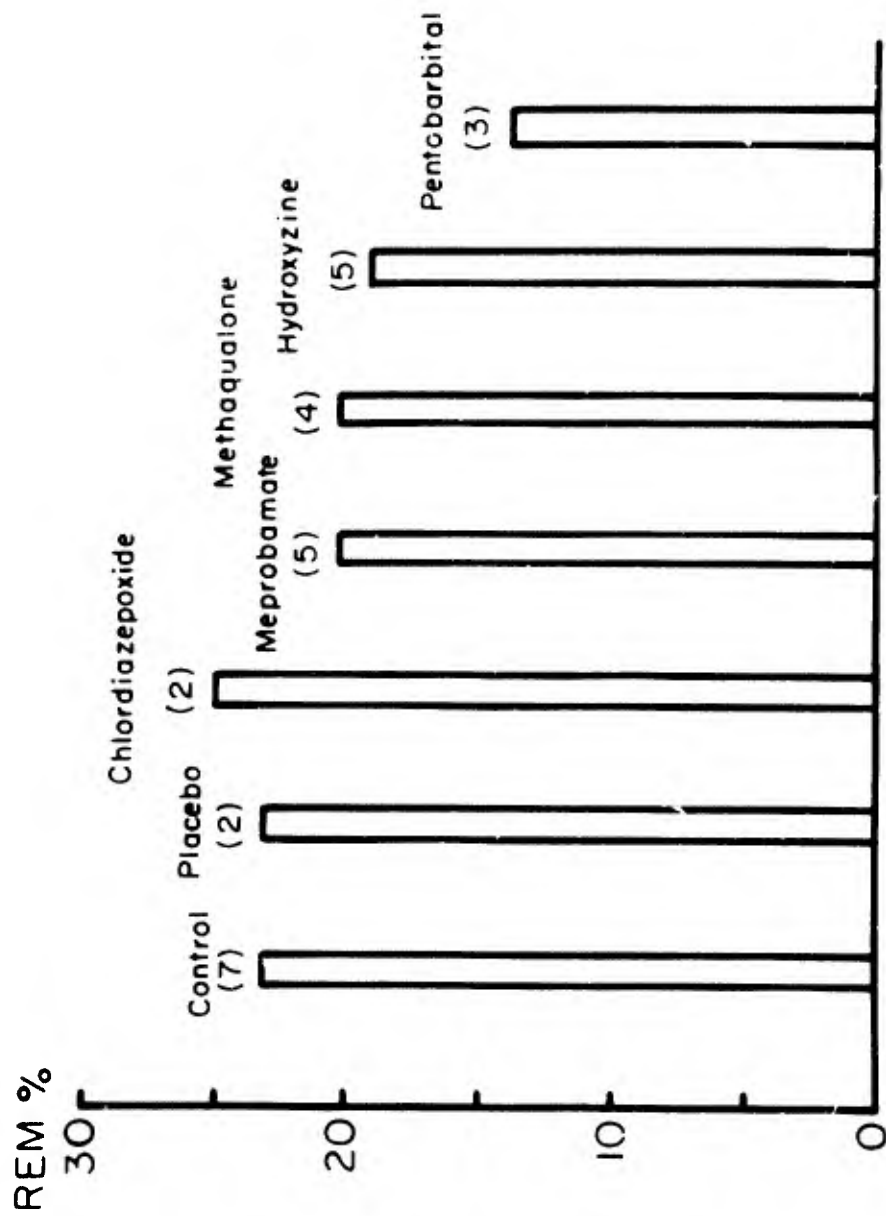

Figure 1. Effects of Various Drugs on REM Sleep Time.

BLANK PAGE

NOREPINEPHRINE AND SEROTONIN EFFECTS ON SLEEP,
ALERTNESS, AND TEMPERATURE REGULATION

by

Thomas J. Crowley, Captain, USAF, MC

6571st Aeromedical Research Laboratory,
Holloman Air Force Base, New Mexico, USA

SUMMARY

Both norepinephrine and serotonin occur naturally in the central nervous system and may act as central regulators of temperature in lower animals. Many drugs which lower brain norepinephrine and serotonin levels also diminish alertness and induce sleep. In this study the details of these changes are examined in primates. Specific changes in the EEG of sleeping monkeys follow injections of norepinephrine and serotonin into the cerebral ventricles. Lethargy and slowness develop in monkeys treated with alpha-methyl-paratyrosine, a depleter of brain norepinephrine. These manipulations also change brain temperature, suggesting a possible role for norepinephrine and serotonin in the diurnal regulation of sleep and temperature.

Norepinephrine and Serotonin Effects on Sleep, Alertness, and Temperature Regulation

Sleep, fundamental, undeniable, and highly significant to the waging of war, had been little studied and little understood until recently. Man's need for sleep has shaped events in all of his wars, but until the 1950's, we could detail a military man's sleep only a little better than could Thucydides 2400 years ago. Recognizing the disparity between sleep's military importance and our knowledge of it, the U. S. Air Force is actively studying the nature of sleep, its causes, and its effects.

Dement and Kleitman (2) showed in 1957 that sleep is not a unitary state. They differentiated wakefulness and 5 stages of sleep in all-night polygraphic recordings of their subjects' electroencephalograms (EEG), eye movements or electro-oculogram (EOG), and muscle potentials or electromyogram (EMG).

Reite (who later worked at our laboratory) et al. (9), Weitzman et al. (13) and others recorded from subhuman primates sleep patterns very similar to those of humans. Accordingly, our studies beginning in 1964 (11) have used rhesus monkey, chimpanzee, and human subjects. The waves of the cortical electroencephalogram of the waking subject in Fig. 1 represent changing voltage differences between corresponding points of the left and right cortex. The electrical field of the eyeball changes the voltage difference between two nearby electrodes when the eye moves, so the electro-oculogram of Fig. 1 is a record of eye motion. The electromyogram in Fig. 1 is a record of the electrical activity of muscle tension taken from electrodes buried in muscle.

A little later the same night, this subject, a rhesus monkey, produced the record of Fig. 2. The animal has become drowsy, and its EEG frequency is somewhat slower. The rapid, sharp waves of the waking EOG are now replaced by slower, "rolling" movements, and there now is less muscle activity. This is "drowsy" or Stage 1 sleep. Still later at night the EEG waves of Fig. 3 are definitely slower and of greater amplitude. Sharp "V waves" occur, though less commonly in monkeys than in humans. Muscle tension has fallen and eye movements are rare. This is Stage 2 sleep.

Further into the same night the animal produced the record of Fig. 4. High amplitude, slow delta waves occupy more than half of this EEG record, and so it is classified as Stage 4. Stage 3, intermediate between Stages 2 and 4, is one-fifth to one-half delta activity. The eyes and muscles are quiescent in Stages 3 and 4, and the subject is deeply asleep.

Fig. 5 is a record taken toward the end of the same night. Although the animal's muscles were very relaxed, rapid eye movements were occurring under closed or partially closed lids. Behaviorally the animal was soundly asleep, but the EEG had resumed the amplitude and frequency of the drowsy Stage 1. Understandably, this is known as "Paradoxical Sleep" or "Rapid Eye Movement Sleep" (REM). In this stage humans do all or nearly all of their dreaming.

The activity cycle of sleep and wakefulness is intimately associated with the diurnal temperature cycle. Normal daytime rises and nighttime falls of temperature appear in Fig. 6, a simultaneous 55 hour record of the brain temperatures of two chronically prepared, partially restrained rhesus monkeys. Sleep is important in temperature's cycling, for we have found (6) that the temperature cycle is disrupted when sleep is disrupted. The temperature cycles of each of 3 monkeys continuously kept awake 7 days and nights flattened out abruptly after about 24 hours of sleep deprivation and began returning 24 to 48 hours after deprivation ended.

Carrying our laboratory's interest in the sleep-temperature relationship further, Reite studied monkey's brain temperature during the various stages of sleep. In REM sleep temperature regularly fell, attributed by Reite (8) to an increased flow to the brain of cooling blood in that stage. Fig. 7 is an example of this finding recorded from one of my animals.

The laboratory's experience in studying sleep and temperature afforded a unique opportunity to examine the joint pharmacology of these phenomena. Of drugs active in the brain some change temperature, and some change sleep, and the two groups are significantly related. We are studying the possible roles of norepinephrine and serotonin in sleep and temperature regulation. These amine compounds occur naturally in the central nervous system with the highest concentrations in structures around the third ventricle. It is commonly thought, though not proved, that serotonin and norepinephrine either affect or actually are synaptic neurotransmitters in the C.N.S. The compounds have been implicated in at least 3 significant fields.

1. Behavior and Emotional Illness. Reserpine, a drug which reduces brain levels of norepinephrine and serotonin sedates animals and causes clinical psychiatric depression. Drugs thought to increase the amount of norepinephrine and perhaps of serotonin at synapses reverse depression and may cause pathologic elation. These drugs include monoamine oxidase inhibitors, imipramine, and amphetamines (12).

2. Temperature Regulation. Neither norepinephrine nor serotonin cross the blood brain barrier, but when Feldberg, Hellon, and Myers (3) injected the compounds directly into the cerebral ventricles of cats and dogs, they found that with serotonin the body temperature went up, and with norepinephrine it went down. These effects are reportedly (1) reversed in sheep and rabbits, but that does not contradict Feldberg's hypotheses that norepinephrine and serotonin may be important regulators of body temperature.

3. Sleeping EEG. Included among the large number of drugs that alter sleep and its EEG record are those that change norepinephrine and serotonin levels. Amphetamines (7), imipramine (5), and monoamine oxidase inhibitors (10) all appear to increase norepinephrine at the synapse and decrease the percent of REM sleep. Reserpine, which diminishes cerebral norepinephrine, increases the percent of REM sleep (4).

Two essential facts emerge from this information. The diurnal sleep-wakefulness cycle and the diurnal temperature cycle are intimately related. And both sleep and temperature have changed with experimental manipulations of norepinephrine and serotonin. The U.S. Air Force is studying norepinephrine and serotonin to determine whether they are significant controllers of sleep and temperature cycles in primates, including man. Since species differ in their responses to norepinephrine and serotonin, primate subjects are essential for the research to have human application.

NOREPINEPHRINE INJECTIONS Two rhesus monkeys were the subjects of the first study of this series. Each animal had permanently implanted bone screws, depicted in Fig. 8, which served as electrodes for recording EEG, EOG, and EMG. Each also had a thermistor permanently implanted in the hypothalamus for temperature measurement. And in each animal a special cannula led to the third ventricle for drug injections. A long tube connected the cannula to a pump outside the animal's chamber. The animals, partially restrained in chairs, remained continuously in the air conditioned study chamber. The chamber lights were off for 8 hours every day. The animals did a simple avoidance task during the time the lights were on, assuring that most

of their sleep occurred in the dark period. EEG, EOG, EMG and brain temperature were continuously recorded during the dark period. On infusion nights the cannula delivered 3 injections per night of about $110 \mu\text{g}/\text{kg}$ norepinephrine bitartrate into the third ventricle of the animal under study. The cannula delivered control saline injections on other nights.

It is apparent from Fig. 9 that the percent of sleep time this animal spent in REM is much lower on nights of norepinephrine injections than on nights of saline or no injections, and Fig. 10 shows that the effect was even stronger in the other animal.

The brain temperature record of one night without injections appears in Fig. 11. A night with saline injections appears in Fig. 12, and the saline altered the temperature very little. Norepinephrine injections, as seen in Fig. 13, regularly depressed the temperature.

One of the two animals usually awakened after norepinephrine injections but not after saline injections. In this animal the difference in wakefulness was statistically significant, but not in the other animal.

This study suggests that cerebral norepinephrine decreases REM sleep and temperature in primates, and also that norepinephrine may contribute to wakefulness.

NOREPINEPHRINE DEPLETION Pursuing the matter further, we did a pilot study of the effects of alpha-methyl-paratyrosine (AMPT) upon monkeys. This compound interferes with the synthesis of norepinephrine in brain and other organs, gradually depleting them of norepinephrine. Reserpine, which depletes the brain of both norepinephrine and serotonin, sedates animals and humans. Does this sedative effect result from the depletion of norepinephrine or of serotonin? AMPT's depletion of only norepinephrine presents a tool for answering this question.

Two monkeys implanted with chronic bone screws for EEG, EOG and EMG recording and cortical thermistors for brain temperature recording were the subjects of this pilot study. The standard injection was 300 mg of AMPT in 7 cc of diluent delivered intraperitoneally, and control injections were of diluent alone. After about 250 mgm/kg total dose over about 24 hours one animal was lethargic and partially sedated. Treated more gradually over 48 hours, the other animal took about 470 mg/kg to reach the same behavioral state.

During treatment both animals gradually became slower in their movements. As the sedation progressed, they ate less and less. Given bananas, they would take a few bites and then drop the fruit. They drank little or no water. They alerted for a moment if a human entered the test chamber, but then their eyelids again partially drooped and they ceased visual tracking. The facies gradually dulled, and the eyes rolled slowly and aimlessly. Before treatment both animals frequently displayed the normal aggressive threat gestures of the rhesus monkey. Their teeth bared and mouths open, with snorting vocalizations, they cast head and arms rapidly toward anyone who came near. But under treatment the aggressiveness dulled and finally ceased. Even immediately vis-a-vis with a human, they mustered no response, or only a feeble baring of the teeth without opening the mouth, vocalizing, or moving. The pupils remained normal or slightly constricted, but the extremities became cold. Removed from their restraining chairs and on leashes, the animals did none of the exploring common to rhesus monkeys. They assumed odd postures and remained in them until forced to move. One sat on the floor, placing head and elbows between her knees, and the other developed definite cereas flexibilitas. If her hand was raised above her head, it remained there 10 to 20 seconds before gradually sinking downward. After treatments were ended, the animals' behavior returned to normal within 18 hours.

This pilot study did not yield enough information to make definite conclusions about AMPT's effect on EEG and temperature, but we can state conclusively that the subjects showed dramatic and rather bizarre lethargy and sedation when treated with the norepinephrine depleter, AMPT.

SEROTONIN INJECTIONS At the present time we are injecting the third ventricle of sleeping monkeys with serotonin. The data are not yet complete, but it appears that serotonin, surprisingly, changes monkey brain temperature in the same direction as norepinephrine. Furthermore, our initial injections partially suppressed REM sleep.

There are at least 3 reasons for the research of the Air Force in the biochemistry of sleep. The first and most obvious is that one-third of our man-hours are spent in sleep and that sleep is an essential ingredient of the manning and timing of military missions. When we can describe sleep we may be able to control it. Secondly, insights gained from this research could be of value in the treatment of psychiatric depression or elation, since norepinephrine or serotonin may be important in both conditions. Finally--and most ominously--our

demonstration that interference with norepinephrine metabolism produces lethargy and bizarre behavior in primates suggests that the Free World must lead in this research. The usual atropine injection would not defend against a chemical warfare agent which depletes norepinephrine, and if such agents appear, we must know more about norepinephrine's role in the central nervous system.

REFERENCES

1. Cooper, K.E., Cranston, W. I., Honour, A.J. J. Physiol. 181, 1965, 852-64.
2. Dement, W., Kleitman, N. EEG Clin. Neurophysiol. 9, 1957, 673-90.
3. Feldberg, W., Hellon, R.F., Myers, R.D. J. Physiol. 186, 1966, 416-23.
4. Hartman, E. Psychopharmacologia (Berlin) 9, 1966, 242-7.
5. Hishikawa, Y., Nakai, J., Hidenobu, I., Kaneko, I. EEG Clin Neurophysiol 19, 1965, 518-21.
6. Pegram, G.V. Changes in Performance, Temperature and EEG as a Function of Prolonged Sleep Deprivation. Univ. of New Mexico, Ph.D. Dissertation (In Preparation), 1967.
7. Rechtshaffen, A., Maron, L. EEG Clin Neurophysiol 16, 1964, 438-45.
8. Reite, M., Pegram, G.V. Abstract presented at Assn. for Psychophysiological Study of Sleep, Annual Meeting. Santa Monica, California, 1967.
9. Reite, M., Rhodes, J., Kaven, E., Adey, W. A.M.A. Arch. Neurol. 12, 1965, 133-44.
10. Reite, M., Stephens, L.M., Lewis, O.F., Pegram, G.V., Bixler, E. Abstract presented at Assn. for Psychophysiological Study of Sleep, Annual Meeting. Santa Monica, California, 1967.
11. Rickles, W.H. ARL Technical Report 65-19, 1965. 6571st Aeromedical Research Laboratory, Holloman Air Force Base, New Mexico 88330.
12. Schildkraut, J.J., Kety, S.S. Science 156, 1967, 21-30.
13. Weitzman, E.D., Kripke, D.F., Pollak, C., Dominguez, J. Arch. Neurol. 12, 1965, 463-7.

MONKEY 279

25 APRIL 1967

AWAKE

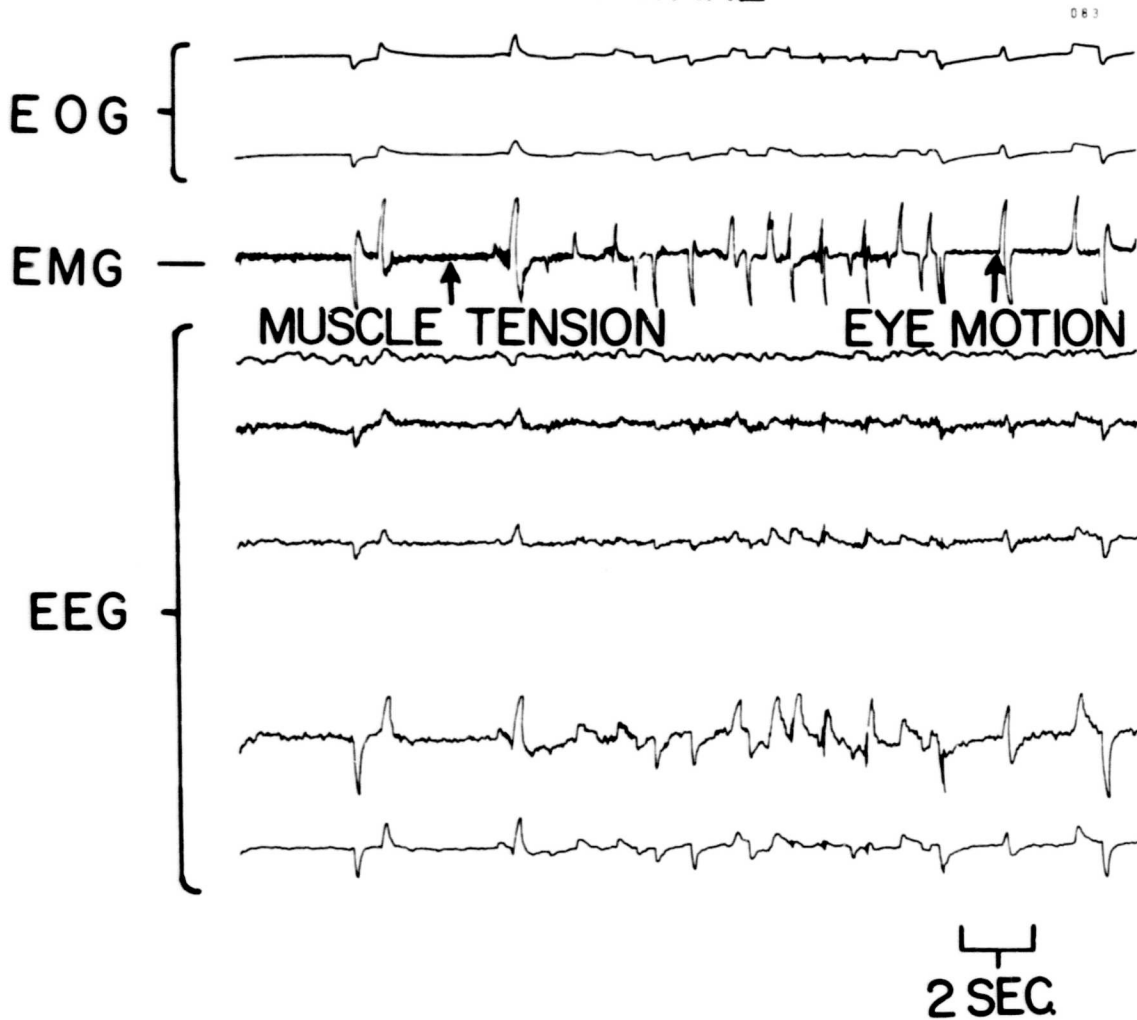
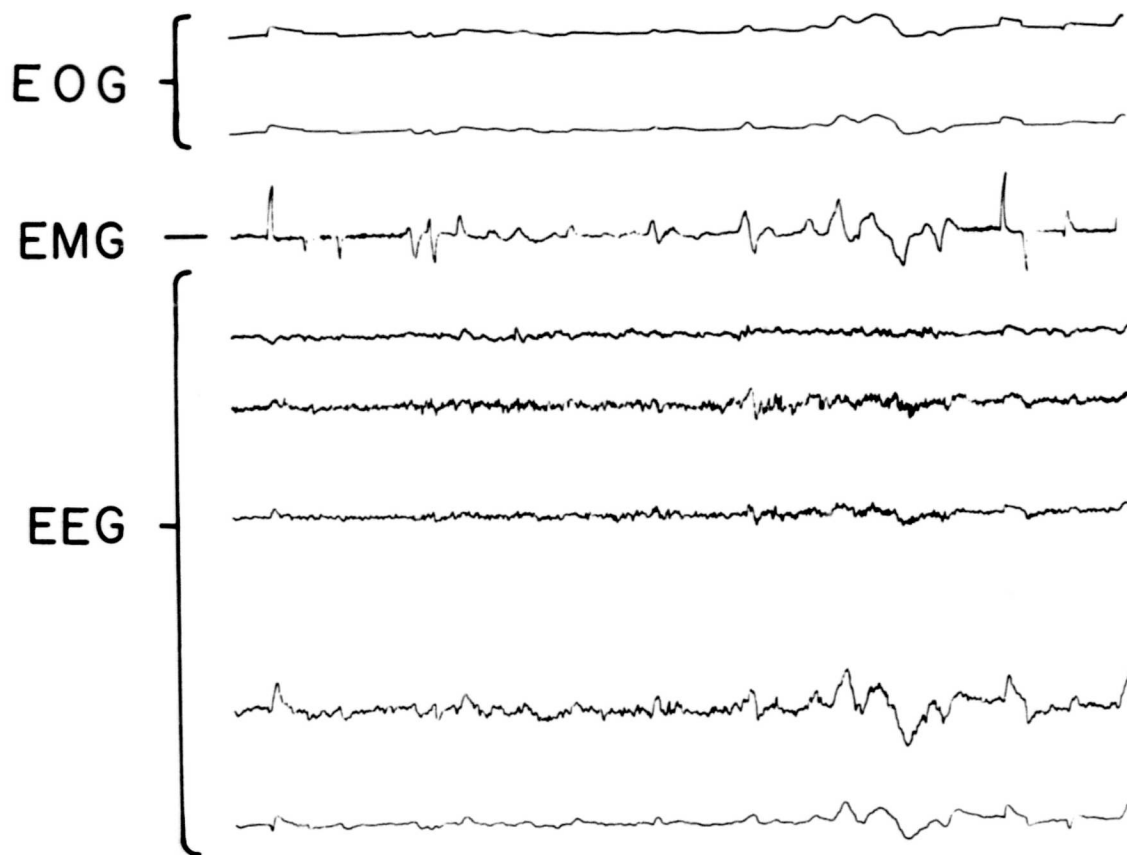

Fig. 1. Polygraph Record. EOG, or electro-oculogram, records the movement of the left eye (upper channel) and of the right eye (lower channel). EMG, or electro-myogram, records muscle tension as low-voltage, fast activity. Spikes in the EMG are eye motion artifacts. From above downward EEG, or electroencephalogram, records hypothalamic, trans-occipital, trans-parieto-occipital, trans-parietal, and trans-frontal voltage changes. Note eye motion artifact in parietal and frontal leads.

MONKEY 279

25 APRIL 1967

STAGE I



2 SEC.

Fig. 2. Polygraph Record. Same leads as Fig. 1.

MONKEY 279

25 APRIL 1967

STAGE II

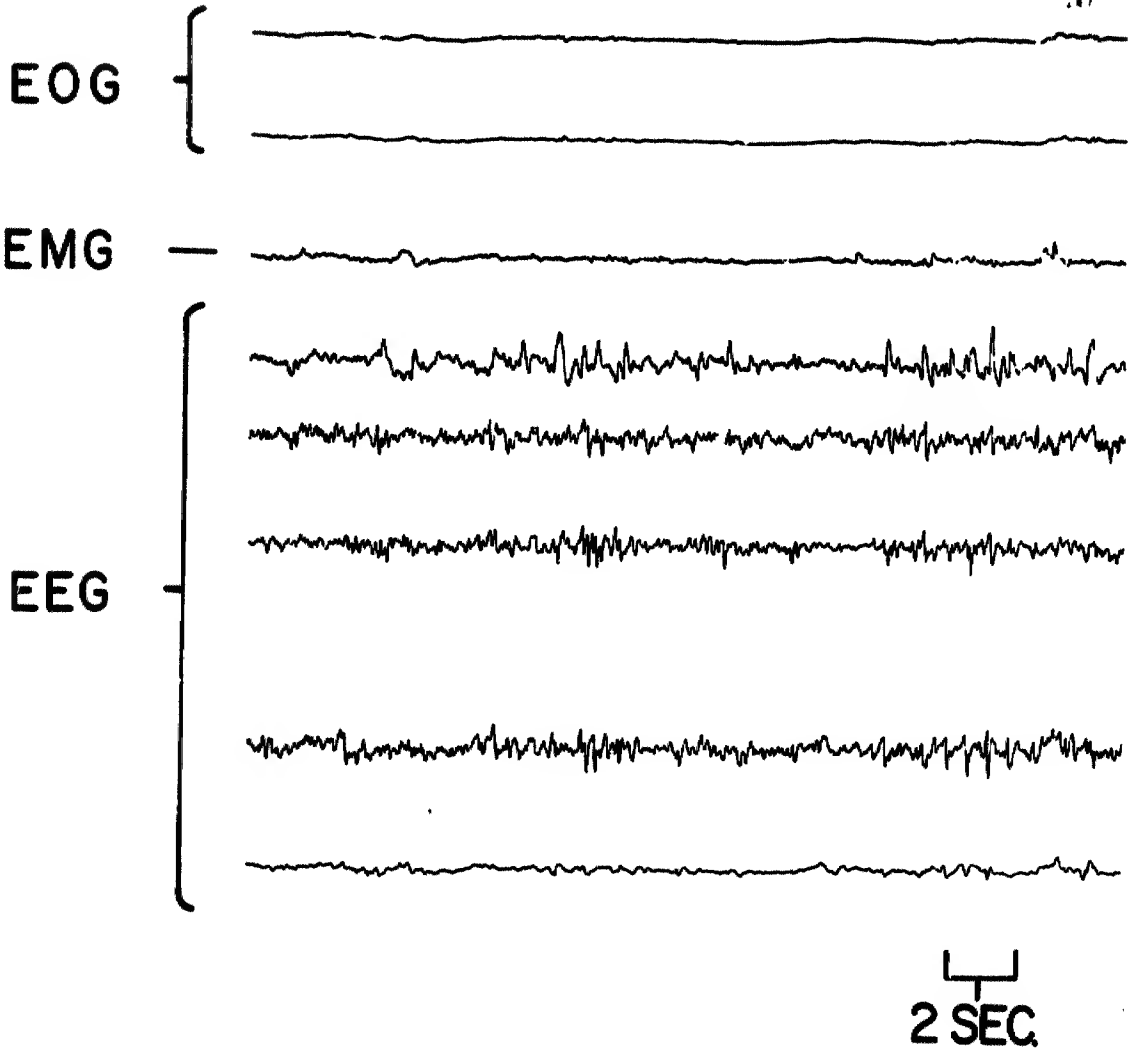

Fig. 3. Polygraph Record. Same leads as Fig. 1.

MONKEY 279

25 APRIL 1967

STAGE IV

465

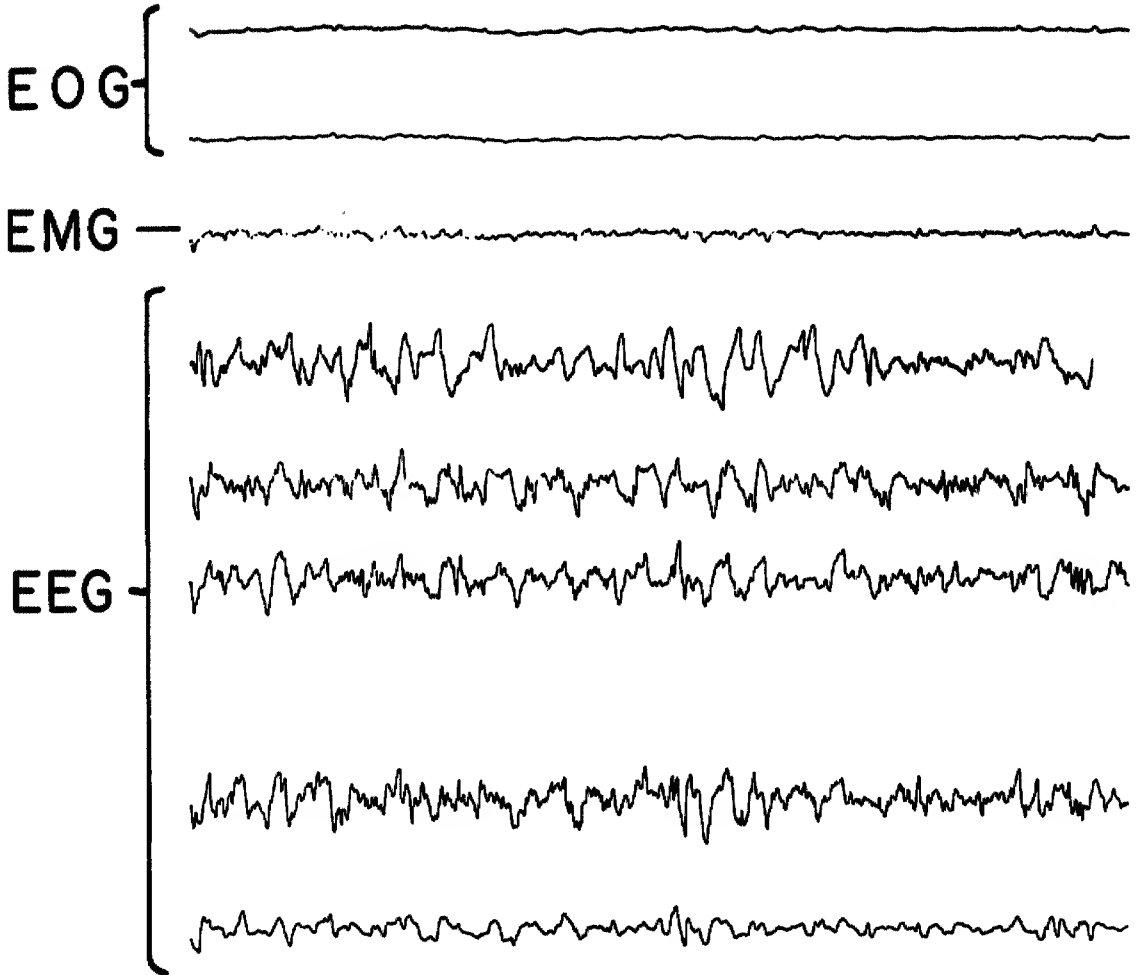

2 SEC.

Fig. 4. Polygraph Record. Same leads as Fig. 1.

MONKEY 279

25 APRIL 1967

REM

12.

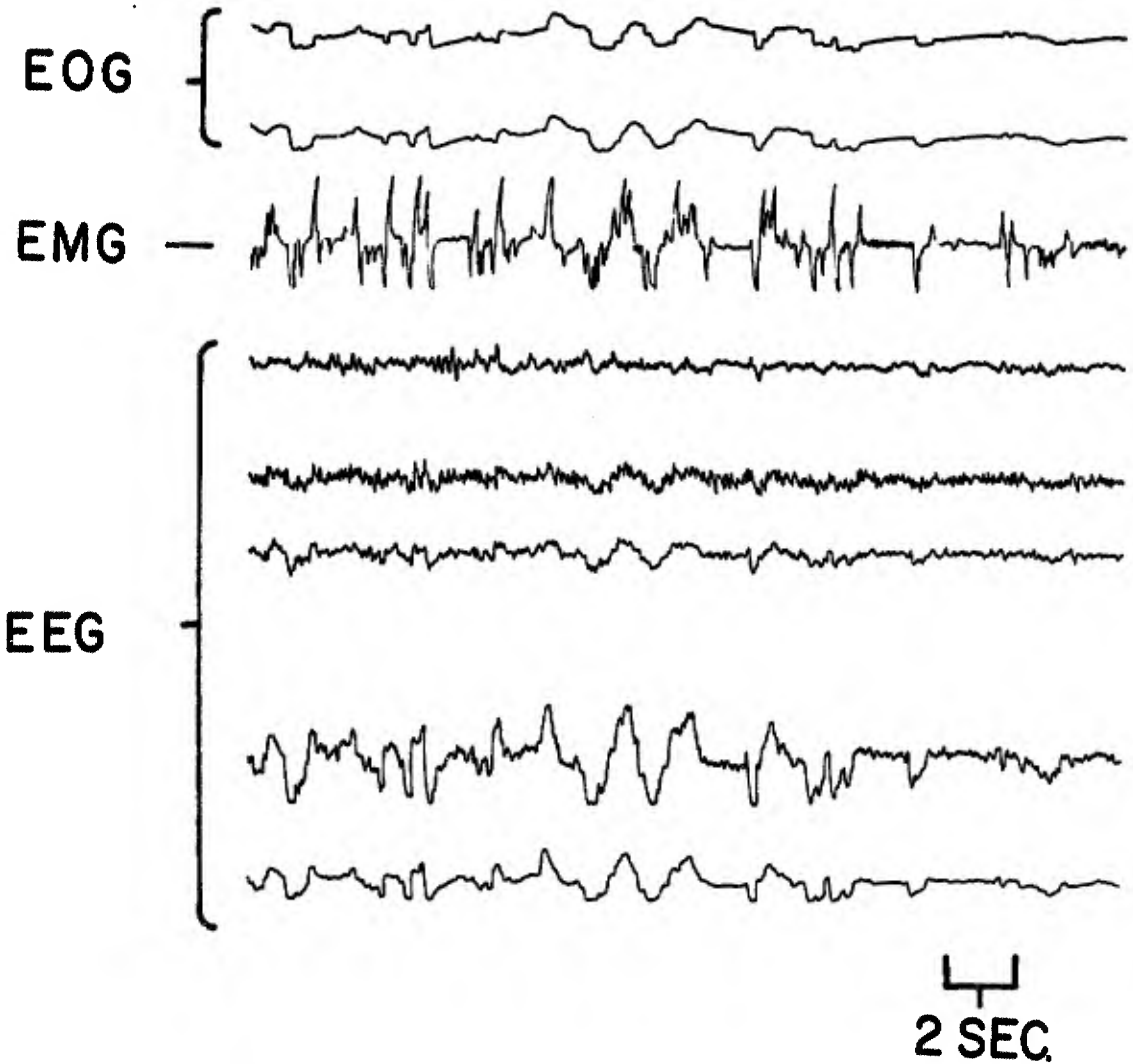

Fig. 5. Polygraph Record. Same leads as Fig. 1. Note reappearance of eye motion artifacts in parietal and frontal leads.

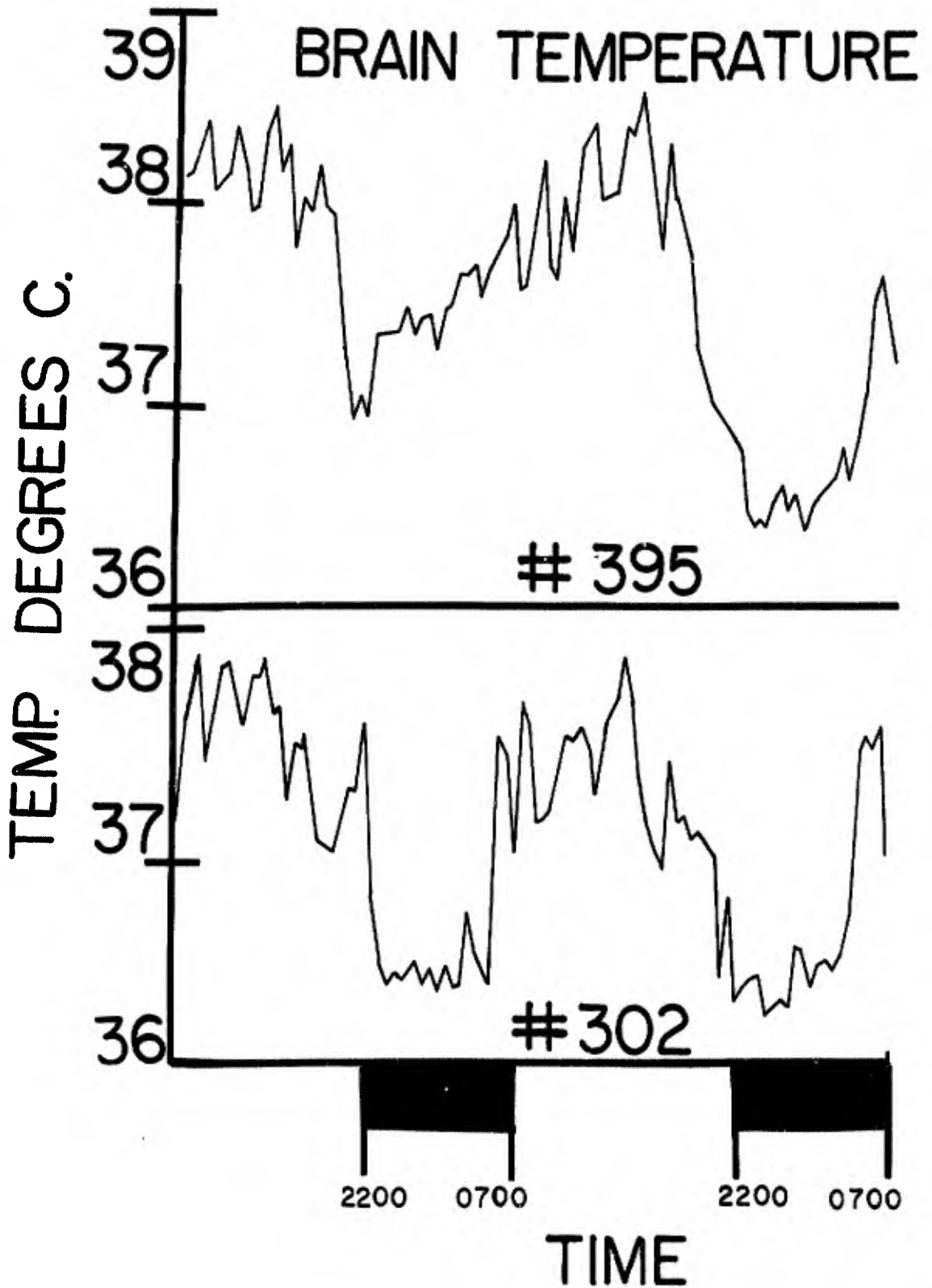

Fig. 6. Brain temperature simultaneously recorded from two rhesus monkeys for 55 hours. The lights were dimmed from 2200 hours to 0700 hours.

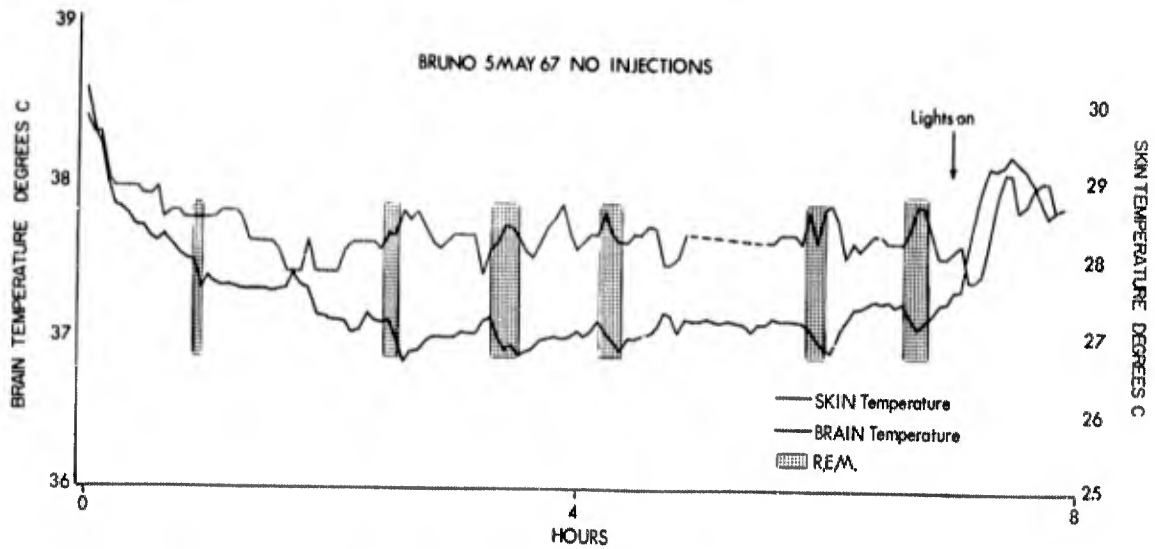

Fig. 7. All-night brain and skin temperature, Monkey 379. Brain temperature consistently falls during REM sleep.

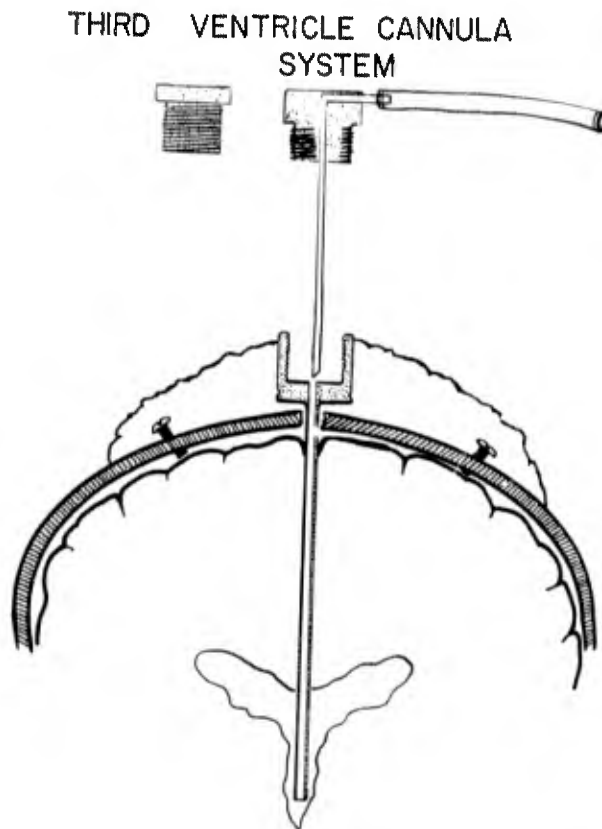

Fig. 8. Injection Device. The screw base is permanently secured to the skull with acrylic cement, which is in turn secured by screws through the bone. The screws also serve as electrodes for EEG recording.

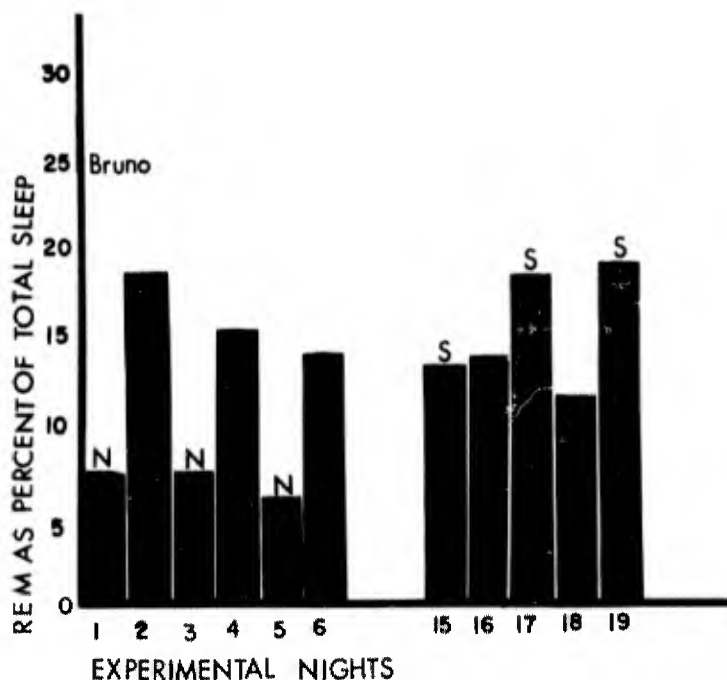

Fig. 9. REM Time/Total Time Asleep, 11 Nights, Monkey 279. N marks nights of norepinephrine infusions. S marks nights of saline infusions. No infusions on unmarked nights.

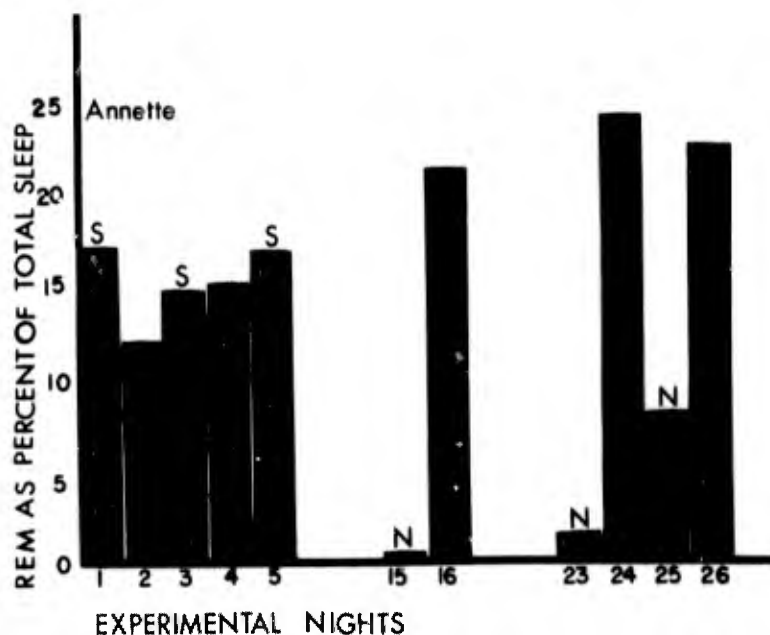

Fig. 10. REM Time/Total Time Asleep, 11 Nights, Monkey 463. N marks nights of norepinephrine infusions. S marks nights of saline infusions. No infusions on unmarked nights.

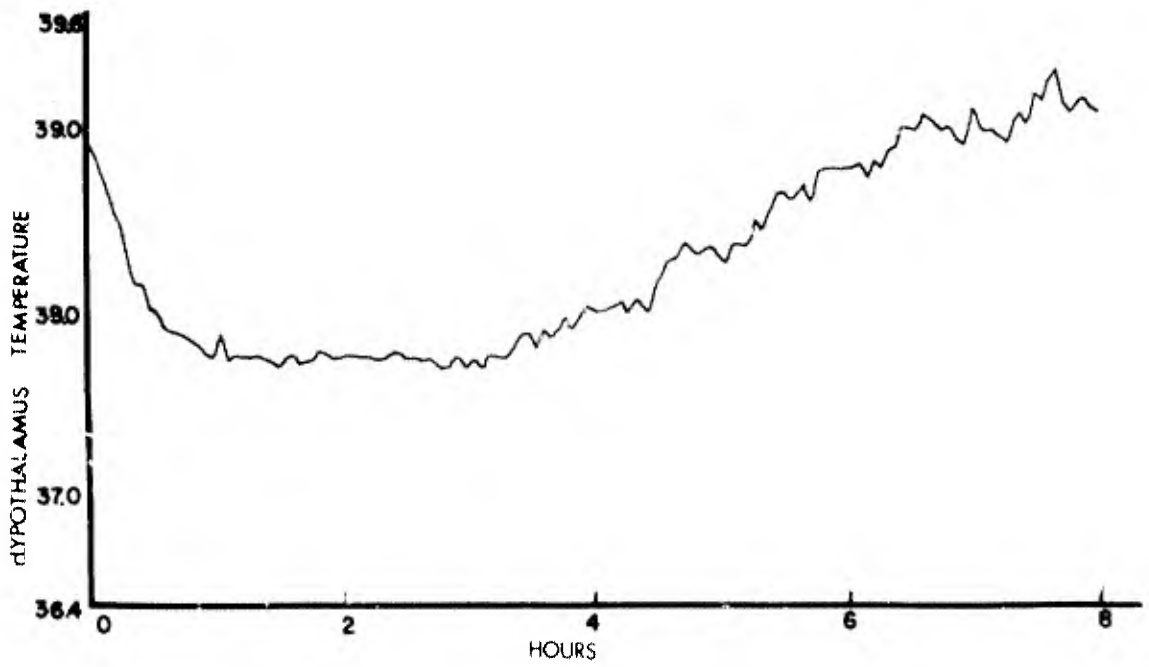

Fig. 11. All-Night Brain Temperature, Monkey 463. No infusions.

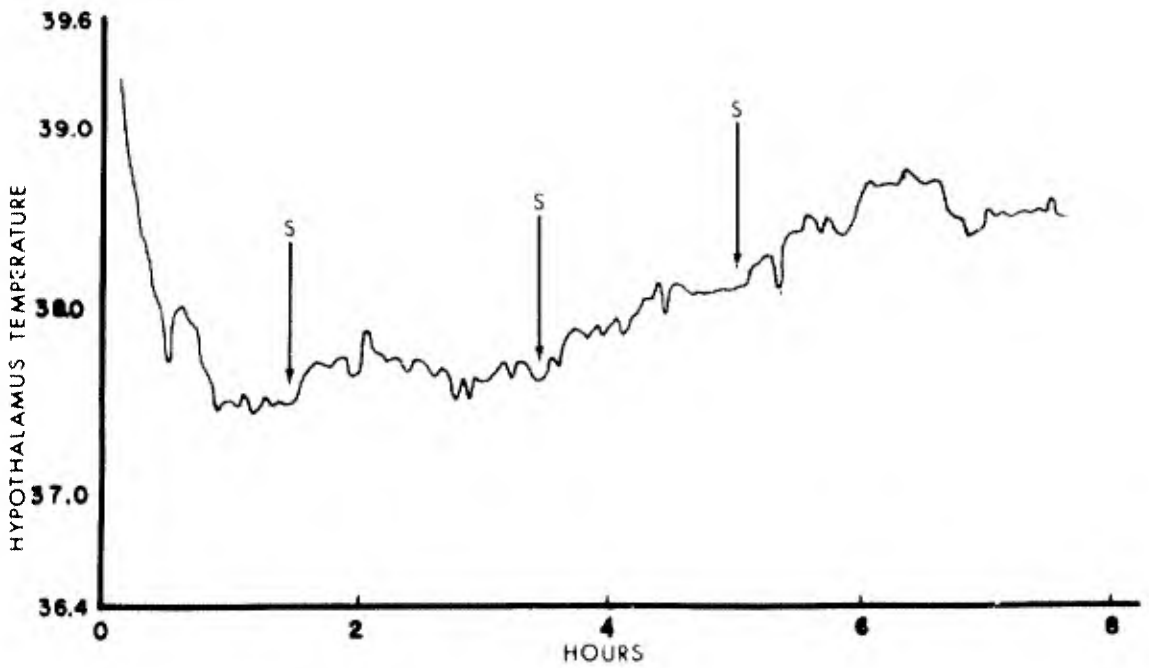

Fig. 12. All-Night Brain Temperature, Monkey 463. Saline infusions at arrows.

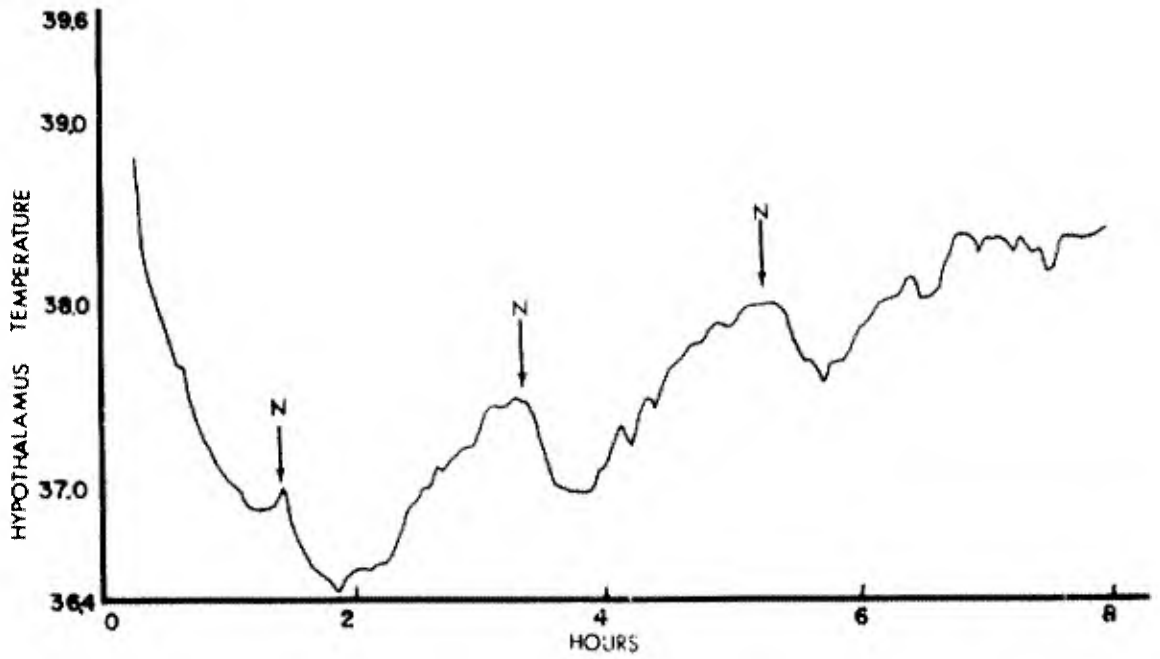

Fig. 13. All-Night Brain Temperature, Monkey 463. Norepinephrine infusions at arrows.

**ELECTROCARDIOGRAPHIC SURVEY OF ROUTINE
DUTY DAYS IN HELICOPTER PILOTS**

by

Lt Col W.P. Schane

**US Army Aeromedical Research Unit
Fort Rucker, USA**

ELECTROCARDIOGRAPHIC SURVEY OF ROUTINE DUTY DAYS IN HELICOPTER PILOTS

Lt Col W.P. Schane

INTRODUCTION

In the last year we have had the opportunity to examine one lead of EKG of over 100 pilots while each was engaged in his regular daily activity. The data I will present was obtained from the records of 53 of these subjects. All of this group were helicopter instructor pilots engaged in flight training of students. This study constitutes one of a group of studies underway in our laboratories to evaluate the interaction between man and the flying systems and environment in an attempt to improve our understanding of the responses of the cardiovascular system to flying, and to attempt to establish realistic selection and retention standards for U.S. Army helicopter pilots.

METHOD

The subjects came to our laboratory in the morning, before reporting for duty. At that time bisternal electrodes were attached, one over manubrium sterni, and the second over corpus sterni at the level of insertion of the 5th costal cartilage. A single lead of EKG, comparable to lead V_2 , was recorded on 1/4 inch 0.5 mil Mylar magnetic recording tape by a 3 1/2 lb self-contained tape recorder at a tape speed of 7 1/2 inches per minute. The pilot then reported for regular duty. During the day he filled in a questionnaire covering his duty assignment, general physical condition, flying experience and accident record, and kept a log of his activities. These were used during data reduction to relate to heart rate and rhythm. At the end of his duty day he returned to the laboratory to have the equipment removed.

Tapes were read in the following manner:

1. A continuous write out of heart rate expressed as beats per minute was obtained for each record.
2. Scanning was conducted on each record at 60 times real time for observations of rhythm.
3. All periods of special interest were either viewed upon an oscilloscope screen or recorded on standard EKG paper at a 1:1 time ratio.

CALIBRATION

Each strip of magnetic tape was calibrated at the beginning of the recording day with a 1 millivolt signal at a frequency of 1 signal per second. In addition,

the recording tape decks were calibrated weekly with a calibration tape to a tape speed of 7 1/2 inches per 60 seconds. Read-out equipment was calibrated with 60 Hertz oscillation of line voltage and correlated with the 60 signals per minute calibration on the magnetic tape. On the basis of these precautions, plus the manufacturer's specifications for the equipment, it is our opinion that the estimates of heart rate are correct to $\pm 2\%$.

TECHNIQUES

Some points of technique may be of interest.

1. We regularly shaved the chests of our subjects with a number 40 blade of a standard small animal clipper. Only with shaving were we able to maintain stable electrode contact.
2. We took some effort in the preparation of the skin. After shaving, the skin was cleansed vigorously with technical acetone, and rubbed dry. This effectively defatted the skin, which made it possible for our adhesive to hold the electrodes in place for the entire period of study. In addition, the aggressive rubbing produced good skin erythema, and some cutaneous decornification, thereby decreasing skin resistance.
3. As a conductor between the silver electrodes and skin we used bentonite. In preliminary studies we noted lower resistances with silver-silver chloride suspensions, and with sodium chloride in water soluble base, however, these materials were rather fluid, and after activity, the electrode paste tended to pump out of the cup electrodes causing electrode slippage and considerable electrode artifact. Bentonite was more viscid and even after dilution with sweat, did not escape as readily from the electrode cups.
4. Electrodes were held in place using standard 3-inch surgical Elastoplast, reinforced by Blenderm to prevent peeling of the edges.
5. The electrodes were placed bisternally with the reference electrode over manubrium sterni, and the recording electrode over corpus sterni at the level of the attachment of the 5th costal cartilage. This provided a clear P wave, permitting a clear evaluation of rhythm, and a strong signal which was helpful in records in which interference was a problem since it improved our signal to noise ratio.
6. In every subject skin impedance between electrodes was measured with a standard VOM multimeter just after the electrodes were placed, and just before the electrodes were removed. In most instances, initial impedances were in the range of 10K-100K ohms, and final impedances were in the range of 1K-10K ohms.

RESULTS

Analysis of the Population Studied:

Fifty-three (53) helicopter instructor pilots actively engaged in student training during the period of study.

	<i>Range</i>	<i>Mean</i>	<i>Standard Deviation</i>
Age	22-46	30.3018	5.2241
Total Accumulated Flying Hours	700-8200	2208.5471	1490.1405
Average Number of Hours Flown/Month	15-180	53.8113	28.8411
Number of Previous Accidents	0-2	0.4716	0.6077
Number of Hours Recorded in Test	5.25-11.5	7.7452	1.3666
Number of Hours Flown in Test	0.75-6.9	3.6490	1.1323

Analysis of Heart Rates

	<i>Range</i>	<i>Mean</i>	<i>Standard Deviation</i>	<i>Estimated Energy Expended</i>
Administration	65-108	87.2264	10.3879	1.8 K Cal/min
Driving	69-110	85.5280	11.2243	1.6 K Cal/min
Eating	70-115	90.1320	11.0992	2.1 K Cal/min
Flying	68-125	92.0377	13.7462	1.7 K Cal/min

Analysis of Variance was Conducted upon this Data

	<i>SS</i>	<i>df</i>	<i>MS</i>	<i>F</i>
Between individuals	22,195.8821	52	426.8438	10.1806**
Between treatments	1,011.6413	3	337.2137	8.0428**
Residual	6,540.6087	156	41.9289	
TOTAL	29,748.1321	211		

A test for multiple comparison of means as described by Tukey was conducted upon the 4 means. It indicated that there was no significant difference between any of these means.

Records were evaluated to determine the lowest and highest heart rates recorded which were sustained for at least 1 minute, and the specific activity of each subject during this period.

	<i>Range</i>	<i>Mean</i>	<i>Standard Deviation</i>
Lowest Heart Rate	50-90	71.8113	9.7192
Highest Heart Rate	100-195	140.3773	20.0204

Activities associated with these rates are as follows:

Lowest Rate:

Driving	20 subjects
Administration	19 subjects
Flying	4 subjects
Eating	4 subjects
Riding in Car	1 subject
Pre-flight	1 subject
Sitting	1 subject
Viewing T. V.	1 subject
Yard Work	1 subject
Reading	1 subject
	<hr/>
	53 subjects

Highest Rate:

Walking	21 subjects
Flying	15 subjects
Pre-flight	5 subjects
Driving	5 subjects
Administration	5 subjects
Eating	1 subject
Running	1 subject
	<hr/>
	53 subjects

A qualitative estimate was made of the physical condition of the subjects using these criteria:

- Class 1 No regular schedule of physical training or sport participation.
- Class 2 Participation in physical training or sporting activities to and including two times each week.
- Class 3 Participation in physical training or sporting activities three times per week or more.

38 subjects (71.7%) were in Class 1

5 subjects (9.4%) were in Class 2

10 subjects (18.9%) were in Class 3

An 11 x 11 correlation matrix was computed in an attempt to show existing correlations within the accumulated data. With an n of 53 an r of:

|0.228| was significant to 0.10

|0.271| was significant to 0.05

|0.357| was significant to 0.01

|0.456| was significant to 0.001

The only significant correlations indicate that persons with high heart rates during any one type activity tend to have high heart rates during all tested activities, and vice versa, a finding which is readily apparent from preliminary reading of the tapes.

In four of our subjects arrhythmias were noted. One exhibited unifocal ventricule premature contractions. Thirty-eight (38) were noted in the period recorded. Three exhibited atrial premature contractions, 5, 12, 22, in the period recorded.

Scanning of the records showed marked axis shift and ST and T wave variability, most often related to heart rate, i.e., as heart rate increased axis shifted to the right, and T wave decreased in amplitude, and vice versa.

DISCUSSION

This brief resume of a pilot evaluation of an on-going project raises a number of questions. The most important of these relates to the impact of helicopter flying upon cardiovascular physiology. In instructor pilots it appears from this data that the impact is not great. We note great individual differences in heart rates between individuals studied, individuals who have a high heart rate for one activity have high heart rates for all (as demonstrated both by the analysis of variance and the correlation matrix), and vice versa. Since it appears that helicopter flying is no more stressful to the heart than automobile driving, one wonders if severely restrictive physical standards of cardiac performance are necessary. No doubt initial examination is essential to exclude applicants with chronic cardiovascular pathology. Yearly examination is advisable, to detect change since the last examination. However, it seems unreasonable to exclude a trained helicopter pilot from flying for trivial and questionable cardiac aberrations.

**THE MORBIDITY OF ARMY AVIATORS,
A PRELIMINARY STUDY**

by

Lt Col R. Bailey

**US Army Aeromedical Research Unit,
Fort Rucker, USA**

THE MORBIDITY OF ARMY AVIATORS, A PRELIMINARY STUDY

It was the opinion of the U. S. Army Aeromedical Research Unit that studies concerning the morbidity of aviators should be of concern and interest to the Flight Surgeon and the medical personnel associated with, and interested in, Aviation Medicine Programs in the Army. Without automatic data processing, however, such data are not only difficult to tabulate, but the statistical processing of the data becomes a large and difficult task. In view of the large aviator population at the United States Army Aviation Center, and our physical proximity to the Aviation Center Hospital, this sort of study was not only feasible, but desirable. The data that we set about to collect and analyze should be able to provide answers to questions such as: 1) Does the Flight Surgeon see different, or unique types of clinical problems among the Army aviation population than the standard population? (Only non-combat personnel are included in this study). 2) Does the special training for aviation medical officers and flight surgeons need to be modified to provide the therapy required by the population they are expected to treat? 3) Does this special population present itself for therapy and treatment of medical problems for which sufficient consideration has not been made prior or during aviation medicine training? This sort of information has been acquired in the past, but has its limitations when applied to the present situation in Army aviation. Not only the flying environment is unique, but the training period of 32 weeks poses a physical requirement that has no provisions for lost time due to illness. A similar study was performed by Graybiel, Brown, and Crispell* at what is now the Naval Aerospace Medical Institute, but has not been reported in the open literature. In that study the aviators' complaints were recorded and analyzed. This study covered a six month period and nearly 16,000 visits. The greatest number of visits were associated with those of an essentially healthy person. The incidence of psychiatric problems revealed were considered one of the most important problems along with air sickness. This initial look at the data we have collected to date is too limited for such a summary statement. In our study, having been forewarned that an aviator may not be always honest about his health, validity was sought by accepting only the official diagnosis of the attending physician. There are those who would challenge this as an absolutely valid method, but if you can't trust your physician.

The method for acquiring diagnosis, biographical information, etc., was as follows. A questionnaire (Figure 1) was required to be filled out by the patient, or

* A Statistical Analysis of the Medical Complaints of Flying Personnel at the Naval Air Station, Pensacola, Florida, by Lt Comdr A. Graybiel, Lt Comdr N. Brown and Comdr R. Crispell, School of Aviation Medicine, USNATC, Pensacola, Fla., 1943.

completed by the attendant in case of incapacity on the part of the patient. This data was transferred to the standard IBM card (Figure 2) by an IBM-026 Key Punch for subsequent processing by computer. Initial data was entered by alpha-numeric coding, but the computer routine does not have the capacity for counting with letters, only digital counting, so we had to write a computer program to convert the alphabetical code to numeric. It would have been nice to avoid this unnecessary step, but the computer was not available at the outset and this pitfall was therefore unexpected. The IBM card (Figure 2) was employed to facilitate processing the data. This card not only provided the means of converting biographical data to digital values and simultaneously storing the information, but was also the means of presenting the data to the computer. The 80 columns were employed as follows: The first 45 columns and columns 60 and 62 were used to encode military, biographical and vital statistic data, columns 46-60 are for information provided by the flight surgeon to include disposition, i.e., duty, or quarters, hospital, grounded, continued on flight status, and the diagnosis of the injury or disease that was treated.

The population for the study was selected as all personnel who were treated at the Aviation or Flight Dispensary, an outpatient facility of Lyster Army Hospital at Fort Rucker. This aviation dispensary treated all Army aviators, all student pilots, enlisted aircrewmembers on flight status, enlisted members of the hospital staff, all commissioned officers at Fort Rucker regardless of flight status, and civilian flight instructors. It should be explained that some civilian instructors are qualified for treatment because they are retired officers or enlisted men. In any event civilian instructors, whether or not they are on retired status, must be seen by an Army Flight Surgeon at the Aviation Dispensary subsequent to being grounded by a civilian physician, or failure to report to the flight line due to illness. Thus the population included a population of commissioned officers, enlisted personnel and civilians as a basis for data comparison.

The diagnoses were made in accordance with the standard Department of Defense Disease and Injury Code, which provides a numerical designation of all diseases and injuries facilitating automatic data processing. In order to be employed in this type of study it is necessary to modify this code by a suffix code. For example, in gall bladder disease there are 27 different diseases of the gall bladder covered by the DOD code number 5860. In strabismus the phorias and tropias are not differentiated so that additional suffix codes were also required to provide sufficient detail for this particular disease code. One questionnaire and one card is prepared for each visit. This initial study is concerned with the computer processing of 9,000 cards out of a total of over 13,000 collected so far. For this reason our study is not complete. Even so, to provide all the data accumulated to date is beyond the limit of one paper. Therefore, let me present a few of the trends and interesting bits of information that have resulted in the first 9,483 sick call visits.

These visits were made over a period of 22 months beginning in June 1964.

1. The average number of sick call visits for each aviator that went on sick call was 1.96; student pilots 1.89; non-aviators 5.20.

2. The maximum number of visits for any one person was 32 visits. He is unidentified at present, but we can and will know his identity and why before the completion of the study. This will require a small computer program, after more important programs are completed.

3. The average age of Army aviators appearing on sick call was 31.5 years and the average age of student pilots was 25.75 years. We were surprised to find our student population was not younger, since they are accepted at age 18 and the upper age limit is age 30. The ideal mean would be 24, which falls within ± 4.09 years, our standard deviation. Therefore, we do not have a bimodal distribution of ages. Although we do have a slight bias toward the older group we have not been able to find trends that indicate any significant number of diagnoses associated with the aging process. We really expected to find student pilot ages much younger.

4. The most common cause, as we might have expected, for sick call visits was upper respiratory complaints. No significant difference between students, aviators and non-aviation personnel. These complaints constituted 19% of visits. Pharyngitis was separated as a single diagnosis and accounted for 6% of the visits so that really over 25% were URI.

5. Next to the URI was gastroenteritis complaints, composing 7% of the visits. Again no significant difference between aviator, non-aviator, or student pilots.

6. Back injury was the largest category of traumatic injury. In back sprains the difference between aviators was statistically significant. The aviators having a higher incidence than the students, or other category. It is interesting that sprains of the extremities, i.e., wrist, ankle, knee, were significantly higher for students than those for any other category. Students are also in a special group in that they represented the only group treated for air sickness.

7. Ear infections represented almost 5% of the visits. Chronic otitis was diagnosed in 10% of these in the aviation population in spite of the annual physical safeguard. The student aviator population that were reported with this disease were significantly larger than other groups.

8. Eye diseases constituted 2.3 percent of the visits. The most common diagnosis was conjunctivitis. There were no statistical differences between visits for refraction, hordeolum, etc., for any of the groups.

It is interesting to compare this data with the 1943 Navy study. First there are differences of training in which the Navy was almost exclusively fixed wing and the present study biased toward rotary wing. The number of persons in the studies is comparable, but the duration and number of visits in this early portion of the study are not. The total of nearly 16,000 in the Navy study will be comparable to our total of over 13,000. This graph shows the Navy results in blue versus our results in red. The large difference in superficial injuries is a surprise. We included cellulitis, acne and every possible diagnosis in this category and were still unable to generate more than 11.65%. Of even more interest is our extremely low incidence of air sickness only 27 cases out of 9,000, or .3% as compared to 4.7% in the Navy study. At this point we can only speculate about fixed wing vestibular stimulation as compared to rotary wing. Headache is reduced a similar amount. Although the geographical location of the bases is very similar we had a much lower incidence of upper respiratory infections. The Navy study was from 1 February to 1 August 1942 and our study continued over 22 months. Therefore the seasonal bias does not appear to be a factor in the incidence of upper respiratory infections.

CONCLUSIONS

We have been stimulated by the air sickness results to quantify the vestibular stimulation produced by the accelerative force environment of the rotary winged aviator. It would appear that this problem is not nearly so great in the rotary winged aircraft. Further, we are conducting a program to evaluate EEG and eye movements simultaneously to provide an objective measure of vertigo produced in these two environments. For the flight surgeon, programs will be run through the computer to cross correlate the data of various factors such as: flying time vs age; military aviation vs age; age vs flying hours; months in military aviation vs flying hours, to develop regression lines that have predictive value.

PATIENT REPORT
AVIATION MEDICINE DIVISION

1-5 Date	9-21 Name (Last, First, MI)	22-31 Serial No.	32-33 Age
34-35 Rank (Please Circle)			
OFFICER		WARRANT OFFICER	ENLISTED MEN
01 0-1	05 0-5	10 WOC	21 E-1 26 E-6
02 0-2	06 0-6	11 W-1	22 E-2 27 E-7
03 0-3	07 Gen. Off.	12 W-2	23 E-3 28 E-8
04 0-4		13 W-3	24 E-4 29 E-9
		14 W-4	25 E-5
36-39 Estimated Total Flying Hours: _____			
40 Present Aviation Rating or Duty:			
1 Army Aviator	4 Observer/Gunner	7 Air Traffic Controller	
2 Student Pilot	5 Aviation Mechanic	8 Flight Surgeon	
3 Crew Chief	6 Civilian Instructor	9 NON-AVIATION Personnel	
41-44 Indicate Number of Months in Military Aviation: _____			
45 Present Flight Status:			
1 Full Flying Duty (FFD)		4 Intermediate Suspension	
2 Full Flying Duty with Waiver (FFW)		5 Indefinite Suspension	
3 Temporarily Suspended (DNIF)		6 Not Applicable	
61 1 This is the first visit for this condition.			
2 This is a repeat visit for this condition.			
62 1 I am a member of the permanent party at Fort Rucker.			
2 Other _____			
FLIGHT SURGEON DIAGNOSIS & DISPOSITION			
46 Disposition (Circle Appropriate No.)		47 Flight Status	
1 Admitted Hospital		1 Full Flying Duty	
2 Admitted Quarters		2 Full Flying Duty with Waiver	
3 Clinical Consultation, USAH		3 Suspended, Temporary	
4 Referred to AMCS, USAARU		4 Suspended, Intermediate	
5 Not Applicable		5 Suspended, Indefinite	
6 Treated, Released			
7 Treated, Return Visit Required			
49 Diagnosis, General (Circle Appropriate Letter)		Diagnosis, Specific	
I Gastrointestinal	U Genitourinary		
P Neuropsychiatric	A Cardiac		
Y Eye	D Medical, Other		
N Ear, Nose, Throat	J Injury	No Disease, Injury, etc., Found	
G Surgical	K Unknown or No	49-60 DDDIC Code:	
R Dermatology	Diagnosis		

USAAVNC(ARU) 1, 1 Jul 65

Figure 1

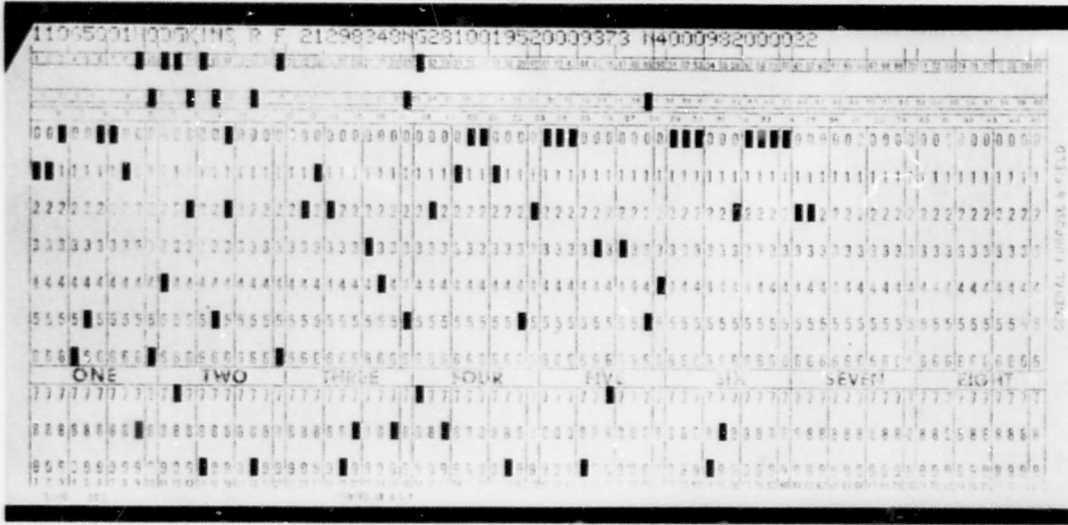

Figure 2

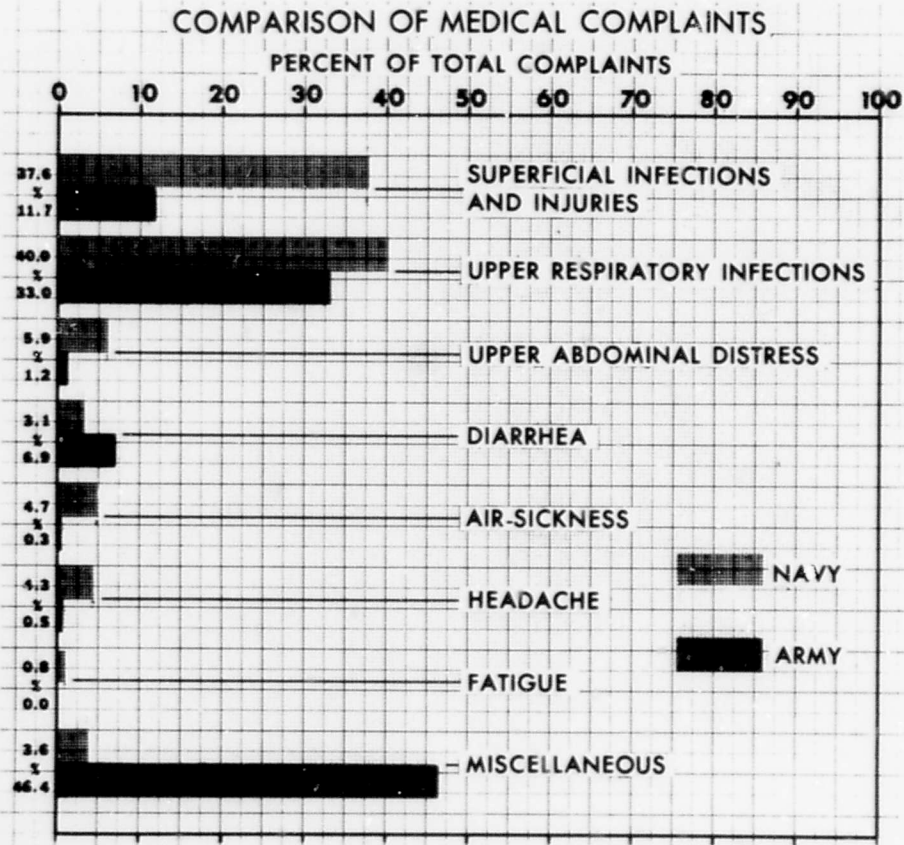

Figure 3

ETUDE DE LA VIGILANCE ET DES REACTIONS PSYCHOMOTRICES
SUR DES PRIMATES PLACES EN VOL BALISTIQUE

par

Médecin Commandant G. Chatelier
et Dr Belugou

French Air Force, C.E.R.M.A., Paris, France

SOMMAIRE

On peut former l'hypothèse que la sensation gravifique participe au maintien de l'éveil cortical. Dans ce cas, l'état de non pesanteur risque d'amener des baisses du niveau de vigilance.

Deux singes ont été conditionnés à effectuer un geste psychomoteur simple puis munis d'électrodes à demeure de façon à pouvoir enregistrer l'électrocorticographie, myographie et phénomènes végétatifs.

Deux tirs de fusée "Vesta" ont permis de recueillir, pendant un vol balistique de 8 minutes, une polygraphie transmise par télémetrie.

Un animal s'est trouvé en état de non pesanteur pur. Il a présenté des fuseaux hypersynchrones du type thêta et une absence complète de geste conditionné. Ces résultats traduisent une forte baisse de vigilance. L'autre singe est resté soumis pendant le vol à quelques dixièmes de G. Il a eu un tracé d'éveil et des performances psychomotrices normales.

ETUDE DE LA VIGILANCE ET DES REACTIONS PSYCHOMOTRICES SUR DES PRIMATES PLACES EN VOL BALISTIQUE

G. Chatelier et Dr Belugou

HYPOTHESE

1. Le niveau de vigilance d'un sujet est fonction, pour une part importante, des différents facteurs d'environnement dans lequel il se trouve. Normalement, l'ensemble des afférences sensorielles: visuelles, auditives, somesthésiques etc. ... s'intègre au niveau du cerveau, en particulier à l'étage réticulaire. Selon la valeur qualitative et quantitative de ces stimuli, la structure réticulée active plus ou moins les régions corticales et contribue ainsi à maintenir la vigilance à un certain niveau.

2. Parmi les afférences sensorielles, la sensation gravifique est normalement perçue au sol, d'une part au niveau de l'oreille interne, par les otolithes des saccules et utricules, jouant le rôle de petits accéléromètres; d'autre part, au niveau des mécanorécepteurs articulaires, musculaires et tendineux. La stimulation gravifique semble donc jouer un double rôle: contribuer, avec les autres stimuli, au maintien d'un niveau d'éveil normal, et, synchroniser, par le jeu de différents réflexes, les tonus des différents muscles en fonction de leur position dans l'espace. Ce facteur gravité est supprimé lors des vols balistiques où orbitaux et l'on pouvait prévoir, chez les astronautes effectuant de telles missions, des modifications de vigilance ou de coordination motrice.

3. Dans les conclusions des vols Gemini publiés par la N.A.S.A., ces troubles n'ont pas été retrouvés. Toutefois, les astronautes sont des sujets dont la physiologie est un peu exceptionnelle du fait de la sévérité de leur sélection et de la rigueur et précision de l'entraînement qu'ils subissent. Malgré cela, quelques anomalies mineures ont parfois été observées portant sur le comportement et les périodes de veille-sommeil.

METHODE

1. Pour mettre en évidence d'éventuelles modifications du niveau de vigilance pendant des séquences de non pesanteur, le Centre d'Enseignement et de Recherches de Médecine Aéronautique a réalisé plusieurs expériences en 1961, 62 et 63 sur des rats et des chats placés en vol balistique au moyen d'avions "VAUTOUR" ou de fusée sonde "VERONIQUE". Les résultats obtenus semblaient montrer des baisses passagères, mais assez profondes, de la vigilance dans certains cas où l'animal s'était trouvé réellement en absence de pesanteur.

2. Pour préciser ces résultats, une nouvelle expérience a été réalisée sur des primates. Les 7 et 13 Mars 1967, deux singes Macaques Nemestrina, sélectionnés parmi 10 autres préparés de la même façon, ont été placés en vol balistique pendant environ 7 minutes au moyen de fusée sonde "VESTA". Après un freinage aérodynamique au moment de la rentrée, un parachute a ramené la pointe au sol et les animaux ont été récupérés vivants et en excellent état.

Les singes étaient porteurs d'électrodes implantées à demeure permettant de recueillir les informations physiologiques suivantes:

- Electroencéphalographie (6 voies)
- Activité de l'hippocampe ventral antérieur
- Myographie de la nuque et du bras
- Rythmes cardiaque, respiratoire, température centrale.

De plus, chaque animal était conditionné à effectuer un geste moteur précis consistant à appuyer sur une petite manette placée au milieu de 4 autres semblables disposées en croix. Le geste était déclenché par un signal lumineux (l'allumage de l'ensemble du tableau) programmé toutes les 20 secondes. L'animal était récompensé après chaque appui correct.

Les singes sélectionnés pour le vol ont été entraînés au laboratoire à subir, sans réaction émotionnelle différentes conditions d'ambiance du vol: isolement dans le container, rotations, bruits etc. ... Toutefois, par prudence les animaux sélectionnés n'ont pas subi d'entraînement en centrifugation.

3. Deux soupapes, placées sur les parois du container, assuraient une ventilation active jusqu'au moment du tir et dès le retour vers 3.000 m. Pendant le vol le container était hermétiquement fermé et des plaquettes d'amiante lithinée absorbaient le CO_2 exhalé par l'animal.

Une caméra 16 mm, filmait en couleurs, pendant la phase balistique du vol l'attitude du singe et, par l'intermédiaire d'un petit miroir, ses gestes et le tableau de test de conditionnement psychomoteur. Les phénomènes physiologiques, physiques et les appuis moteurs étaient transmis au sol par téléométrie puis enregistrés sur piste magnétique et polygraphe à plumes.

RESULTATS

1. L'analyse des fréquences cardiaque et respiratoire recueillies chez les 2 animaux montre que, dans l'ensemble, les différentes séquences du vol ont été bien supportées.

Chez le singe Martine la fréquence cardiaque varie avant le tir entre 230 et 240 par minute. Les variations du rythme respiratoire sont plus amples et prennent des valeurs allant de 75 à 110 par minute. Ces irrégularités traduisent un état d'éveil assez élevé avec de courtes périodes d'agitation. En réalité le singe était assez calme mais s'est agité 3 minutes avant la mise à feu. Ceci se produit fréquemment chez des animaux qui sont enfermés dans un container depuis plus d'une heure.

L'accélération de 2 à 10 G subie pendant la propulsion modifie peu la fréquence cardiaque. Par contre, l'amplitude des mouvements devient de plus en plus ample au fur et à mesure que l'accélération augmente. A la fin de la propulsion, on observe encore 2 à 3 mouvements respiratoires de grande amplitude puis une apnée d'environ 5 secondes.

Ces modifications respiratoires peuvent s'expliquer soit par une action purement mécanique, soit par une réaction du type "action paradoxale de l'oxygène". En effet, si on peut penser à une hyperventilation de réaction au stress d'écrasement relatif de la cage thoracique suivie d'un arrêt dû à une hyperoxie, il est aussi logique d'admettre qu'au cours des accélérations de départ subies en transverse, il se produit une hypoxie, ainsi que divers auteurs l'ont montré (WOOD et coll.). A l'établissement de la non pesanteur, il se produit alors, avec les 2 ou 3 grands mouvements respiratoires une réoxygénation brutale provoquant l'apnée de l'action paradoxale.

Pendant la phase balistique les irrégularités du rythme respiratoire diminuent. De même on observe une baisse progressive et assez constante de la fréquence respiratoire. Cette lente diminution de la fréquence est peut-être plus nette pour l'activité cardiaque.

Cette période de vol est malheureusement trop courte pour qu'on observe une stabilisation. Mais il semble bien que la sous-gravité dérègle les mécanismes régulateurs et que la stabilisation du rythme cardiaque s'opère mal ou très lentement.

Chez l'animal Pierrette on retrouve une morphologie analogue pour les fréquences cardiaque et respiratoire. Toutefois, chez cet animal l'apnée succédant à l'arrêt de la propulsion n'est pas retrouvée et est remplacée par une respiration rapide et très superficielle.

La phase de rentrée avec sa décélération et ses mouvements complexes est assez mal supportée comme en attestent l'agitation et les irrégularités respiratoires et cardiaques. On note une bradyarythmie chez Pierrette pendant cette phase. Mais les deux animaux semblent avoir récupéré très vite. Aucune anomalie n'a été décelée pendant la rentrée stabilisée et au laboratoire après la récupération.

2. Les tracés électrocorticographiques et les réponses psychomotrices sont par contre très dissemblables chez les deux animaux.

Chez Martine, le tracé rapide et désynchronisé avant le départ traduit un état de vigilance normale chez cet animal.

Ce tracé ne se modifie pratiquement pas pendant la période balistique. On note seulement sur les cortex moteurs une modulation par un rythme lent de 2 à 3 cs et la présence d'ondes biphasiques lentes, amples et d'aspect pointu, survenant de façon fréquente et irrégulière. Nous ne pouvons actuellement donner une interprétation de ces accidents. L'animal est resté vigilant comme en témoignent les irrégularités respiratoires et ses performances psychomotrices.

Avant le départ, le tracé Pierrette correspondait à un niveau d'éveil moyen entrecoupé de courtes périodes de baisse de vigilance. Toutefois, pendant la période balistique cet animal a eu un tracé de somnolence presque continu. En effet, l'enregistrement

est caractérisé par la présence de fuseaux, souvent hypersynchrones, de 6,5 cs d'une durée de 10 à 20 secondes, entrecoupés d'une activité moins ample mais peu rapide. Entre les périodes de fuseaux, on note quelques mouvements musculaires brefs. Malgré ce tracé d'assoupissement, existe sur les muscles de la nuque, une activité tonique presque continue. Aucun tracé de sommeil profond n'a été observé.

Il faut reconnaître que le tracé de Pierrette enregistré au laboratoire, montre une tendance spontanée à la synchronisation et lorsqu'il est au calme, cet animal fait facilement des bouffées de fuseaux à 6 - 7 cs, c'est-à-dire du type théta. Les proportions de ces fuseaux théta dans les tracés spontanés ont été mesurées, par l'indice θ/τ (T , étant le temps pendant lequel la durée des fuseaux théta a été mesurée). Cet indice peut représenter un coefficient de somnolence. Nous avons trouvé les valeurs suivantes pour Pierrette:

- Avant le tir: 16 pour cent,
- Mise à feu - propulsion = 0 ,
- Phase balistique = 73,5 pour cent ,
- Retour stabilisé = 13,1 pour cent ,
- Après récupération = 0 .

De retour au laboratoire, des tracés ont été obtenus avec Pierrette placée en centrifugeuse dans les mêmes conditions que pendant le tir, c'est-à-dire, animal enfermé depuis plus d'une heure, centrifugation à 10 G. en 58 secondes, enregistrement maintenu pendant 15 minutes.

Avant centrifugation, nous avons trouvé pour θ/τ des valeurs très variables allant de 2 à 25%. Après centrifugation, ces valeurs varient de 2,5 à 28%. Des essais ont alors été faits pour placer l'animal dans les conditions les plus favorables à la somnolence. Animal nourri depuis peu, centrifugé juste après une période de somnolence spontanée, l'après-midi. Dans ces conditions, le coefficient le plus élevé obtenu est de 28%.

DISCUSSION

Il est sans aucun doute que le vol balistique subi par Pierrette a favorisé grandement une forte baisse de vigilance et un assoupissement. Les résultats psychomoteurs sont également éloquents à ce sujet. L'animal Martine a appuyé correctement dès l'allumage du tableau dans des temps variant de 0"9 à 2"4. Il faut évidemment excepter la réponse très tardive effectuée après l'allumage du tableau survenu juste en fin de propulsion. L'état d'inhibition provoqué par le passage en sous gravité a allongé le temps de réponse jusqu'à 17"9. Ces temps de réponses correspondent exactement à ceux qui ont pu être enregistrés au laboratoire avec cet animal. Il en va différemment pour Pierrette. Cet animal était sélectionné en 2^o position parmi un ensemble de 10 singes. Ses performances psychomotrices étaient comparables au laboratoire à celles de Martine, ses réponses étant toutefois plus lentes un peu moins régulières avec quelques rares erreurs d'appui. Avant le tir, l'animal a appuyé plusieurs fois sur le bouton central du test avant la mise en route de la séquence de travail.

Au premier allumage, l'animal a appuyé correctement mais avec un délai de 30" et n'a donc pas reçu de récompense. Il a ensuite essayé plusieurs autres boutons et a appuyé sur le D au 2ème allumage. Il a encore appuyé 6 fois en dehors de tout allumage jusqu'au moment du tir. Après la fin de la propulsion et jusqu'à la rentrée, 16 allumages du tableau ont été proposés et n'ont déclenché aucun geste. En fin de descente stabilisée, à t 755", l'animal a appuyé sur D, puis sur B, puis sur D.

Le film pris pendant le vol objective l'immobilité de l'animal dont les yeux sont vagues ou miclos, parfois fermés. Un incident peut toutefois expliquer cette absence de geste. Avant le tir, l'animal est resté enfermé plus d'une heure dans le container; à plusieurs reprises, il a actionné les leviers puis s'est agité. Il a réussi alors à attraper un fragment de la gaze de protection recouvrant la plaque d'amiante lithinée placée sur le plafond du container. Cette gaze a été effilochée et tendue sur les boutons du tableau. Cela a sans doute créé une situation nouvelle pour l'animal non habitué à travailler dans ces conditions. Pourtant la gaze était transparente, l'allumage du tableau restait bien visible et aurait pu déclencher chez le singe un réflexe d'appui.

Rappelons que les deux singes étaient à jeun de la même façon et, que dans ces conditions, ils avaient toujours travaillé correctement au laboratoire.

En résumé, l'animal Martine a conservé un tracé d'éveil avec vigilance normale et a travaillé correctement pendant tout le vol.

Pierrette, par contre, n'a effectué aucun appui moteur pendant la période balistique et a présenté un tracé fait de fuseaux plus ou moins confluent traduisant un état de somnolence et une vigilance très basse. Cette attitude est confirmée par le film pris par la caméra pendant le vol. De retour au laboratoire, après la récupération, Pierrette a travaillé correctement avec un tracé d'éveil. L'état de somnolence importante observée chez Pierrette n'a pu être reproduit au laboratoire avec des conditions d'accélération en centrifugeuse, analogues à celles du tir.

Si l'on admet que les conditions du vol balistique étaient analogues pour les deux animaux, il faudrait admettre que la sous-gravité a accentué fortement la légère différence de motivation et les caractéristiques des tracés qui existent chez les deux animaux. Les fuseaux spontanés ont été considérablement augmentés chez Pierrette et une légère modification des conditions de travail a inhibé son geste moteur. Aucune modification de ce genre n'a été retrouvée chez Martine. Un animal qui ne serait donc pas très motivé et présenterait de légères tendances spontanées à la baisse de vigilance verrait ces caractères considérablement amplifiés par un vol en sous-gravité. Une autre explication peut être avancée. Pour le vol de Martine, il a été prouvé qu'un reliquat d'accélération transverse a persisté pendant toute la phase balistique de l'ordre de 0,2 à 0,4 G. Tandis que pour le vol de Pierrette, l'absence de pesanteur paraît beaucoup plus pure et aucun reliquat d'accélération transverse n'est décelable dans le bruit de fond des enregistreurs.

Pierrette s'est donc trouvée réellement privée du facteur pesanteur et cet état vraiment nouveau et inhabituel peut très bien expliquer cette forte baisse de vigilance constatée pendant le vol.

Ceci confirme d'ailleurs ce qui a été vu dans les quelques expériences réalisées précédemment où un chat et un rat se sont réellement trouvés placés en non pesanteur. Chaque fois, des fuseaux lents hypersynchrones avaient été remarqués.

Ces résultats sont résumés dans le tableau suivant:

TIR DU 7. 3. 67. "MARTINE"

	<i>Avant le tir</i>	<i>Phase balistique</i>	<i>Après récupération</i>
Force de la pesanteur	IG	0,2 à 0,4 G oscillatoire	IG
Tracé de vigilance	Désynchronisé, rapide. Rares épisodes d'activité lente et ample - (animal éveillé)	Désynchronisé, rapide. Modulation par O.L. isolées à 2-3 cs. (vigilance normale)	Rapide mais tendance à la synchronisation. Quelques passages d'activité lente et ample. Baisses passagères du niveau de vigilance.
Réponses psychomotrices.		Temps et performances normaux.	Temps et performances normaux.

TIR DU 13. 3. 67. "PIERRETTE"

	<i>Avant le tir</i>	<i>Phase balistique</i>	<i>Après récupération</i>
Force de la pesanteur	IG	0,00 à 0,05 G	IG
Tracé et vigilance	Assez désynchronisé avec prédominance d'une activité à 6-7 cs. Fuseaux thêta: 16% - (vigilance moyenne assez faible)	Activité en fuseaux à 6,5 cs. Presque confluent sur toutes les voies. Fuseaux thêta: 73% - (vigilance très basse)	Rapide, désynchronisé. disparition des fuseaux (vigilance élevée)
Réponses psychomotrices.		Nulles	Temps de réponses très rapides. Performances excellentes.

CONCLUSIONS

Ainsi ces résultats semblent confirmer ceux déjà obtenus lors de nos précédentes expériences avec des rats puis des chats. En effet, dans les cas favorables où l'animal s'était trouvé dans un état de non pesanteur assez pur, on avait noté l'apparition de synchronisation du tracé avec ondes lentes et surtout de nombreux fuseaux hypersynchrones.

Les temps de non pesanteur sont évidemment courts, les expériences trop peu nombreuses. Mais il est troublant de constater que chaque fois qu'un animal s'est trouvé placé en non pesanteur vraie, on ait constaté des baisses de vigilance passagères ou importantes.

Ainsi, il semblerait bien que l'absence de pesanteur produirait un phénomène d'inhibition et favoriserait ou déclencherait la somnolence. Un reliquat de quelques dixièmes de G. suffirait peut-être pour conserver une vigilance normale.

Ces constatations qui confirment celles de CHAMBERS et coll., HARRIS et coll., LILLY et coll. chez des sujets placés en immersion, sont intéressantes au point de vue de la physiologie générale et, par ailleurs, elles justifient la nécessité de l'étude du niveau de vigilance et de ses variations chez les cosmonautes au cours de leur sélection et de leur entraînement.

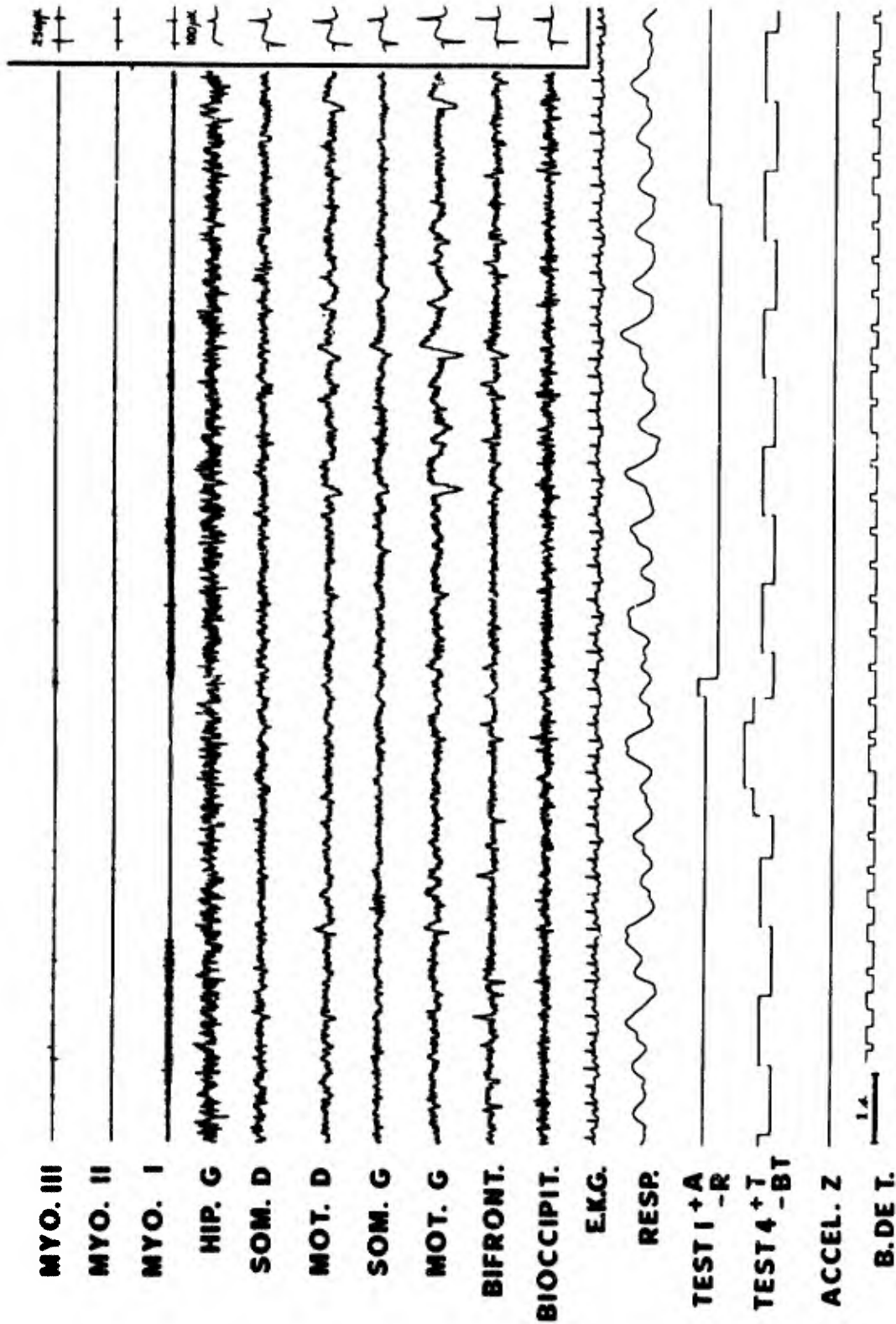

Fig. 1 Experience FU 147. 7-3-1967 "Martine" non pesanteur

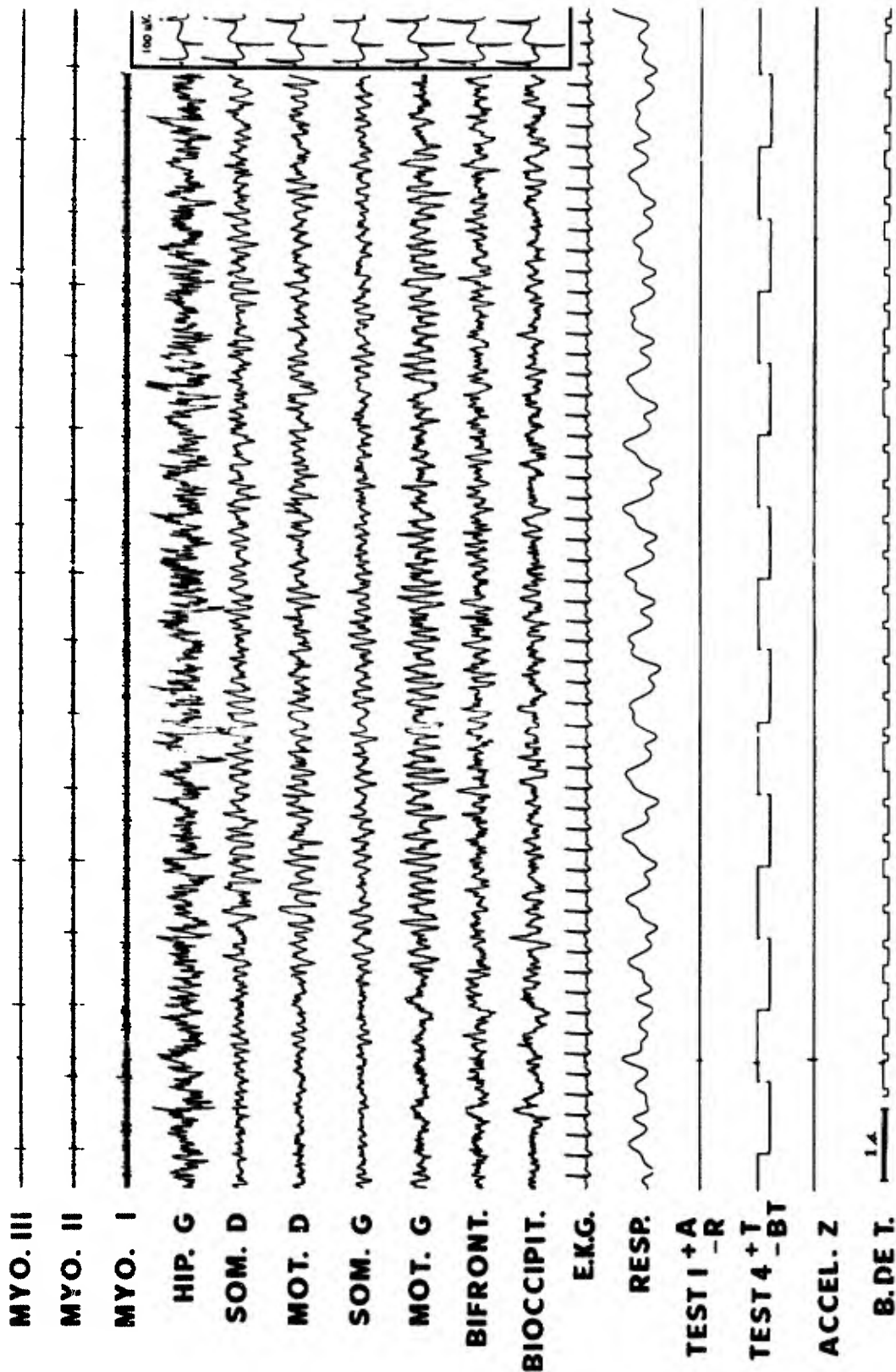

Fig. 2 Experience FU 147. 13-3-1967 "Pierrette" non pesanteur

BLANK PAGE

RECENT WORK ON OXYGEN RICH FIRES

by

Squadron Leader D.M. Densison

RAF Institute of Aviation Medicine,
Farnborough, Hants

Summary

In oxygen rich atmospheres fire can fatally injure normally clothed men with devastating speed. The risk of such accidents is multiplying as the use of these environments increases. Several studies, both in Britain and America, have been provoked by the new problems this situation has created. This paper reviews the work of the past three years.

RECENT WORK ON OXYGEN RICH FIRES

Squadron Leader D.M. Denison, MB, BS, BSc, RAF

RAF Institute of Aviation Medicine
Farnborough, Hants.

Introduction

Much work has been done both in Britain and America on oxygen rich fires in the last three years and this would be a good time to review it and learn of work in other countries.

About 1935 Sir Leonard Hill put a goat in a high pressure chamber full of oxygen and he saw the goat by chance eat a lamp wire. There was a sharp flash and a fierce fire and the goat quickly died. Nine years later an American Fleet lay in the Gulf of Tonkin at war with Japan. On board a salvage ship three divers passed into a surface pressure chamber to speed their decompression by breathing oxygen, perhaps 50% oxygen at two atmospheres pressure. A fan became hot and caught fire, and once more there was a flash and a rapid fire that killed two of the three divers. Eight years later (1952) in America a man was digging a ditch when the air supply to his respirator ran out - no more air was to be found so he was given oxygen instead. A spark from a welding torch touched his face mask, near the expiratory valve, again there was a quick fire and he too died. One morning a few years ago in Tokyo six caisson workers were breathing oxygen from face masks to speed their ascent. All of them were lost when one lowered his mask and lit a cigarette. The air in their chamber was then at a pressure of six atmospheres. At about the same time in New York a ditch digger was trapped to his waist by an earth fall and resuscitated with oxygen. When he came round, a well wisher gave him a cigarette.

There have been many such accidents in oxygen rich atmospheres, three of them recent and well known to you. All of these fires shared the same features, they were most easy to start; they spread very rapidly and they could not be put out. Recent work has shown what must be done to prevent such fires, how and why they spread and how they can be put out in time to stop men dying.

Ignition in Oxygen

Most common substances will catch fire one hundred to one thousand times more easily in oxygen (at one atmosphere) than they will in air (Roth 1964). This means that electrostatic sparks from the human body may have the energy to ignite dirty clothing

(Voigtsberger 1962/63) and that the usually accepted flameproof materials, insulators, and even extinguisher fluids will be flammable. There is also evidence that human flesh will catch light in pure oxygen although it only ignites with great difficulty. At first sight oxygen rich spaces could only be made safe for living by eliminating all electrical circuits and by solely admitting structures and clothing made of pure asbestos, glass, ceramics, or bulk metals. These nihilist discoveries have led other to repeat Voigtsberger's experiments with conflicting results (Purser 1966), so that at present it is not possible to define what electrical circuits are acceptable, but most people agree that potential spark energies of more than 100 millijoules are best avoided. Work at Brooks Air Force Base has shown that sparking metal can be thrown considerable distances while still hot enough to start fires in oxygen, which illustrates that oxygen produces a spatial change in ignition risks.

At the same time other groups of workers have begun searches for new non-flammable materials. Here the problem is that those substances commonly used to fill or dress clothing fabrics and to soften, or otherwise modify plastics and other substances, are themselves flammable and completely new ranges of lubricants, tissues, insulations, soft tubings and the like have to be found. One team, under contract to the US Navy have just published a most valuable review (Cook 1967) describing several advances in this field.

The Spread of Fires in Oxygen

At Farnborough we have mainly been concerned with the problem of how fires spread over the surface of clothing and skin. It has become clear that the rapid spread of fire in oxygen is due to a chain-propagation through the nap of fabrics and the hair of skin, which has the effect of multiplying the rate of spread many fold. An important result of this mode of flash firing is that a normally dressed man can receive fatal injuries within 5 to 20 seconds of his clothes catching light. Detailed studies of nap spread have defined the conditions under which it takes place and give a reasonable model of the phenomenon for predictive purposes (Denison and Tonkins 1967).

Several groups have examined the effects of nitrogen and helium as inert diluents (see for example Clamann 1965; Chianta and Stoll 1966). In general helium is better than nitrogen at reducing the risk of ignition but worse at opposing convective spread. Nap propagation is independent of convective forces and is more effectively suppressed by helium. Draughts of any gas are unwelcome

as they initially increase oxygen flow and accelerate the fire, so neither decompression nor sudden compression with an inert diluent stop fires in the short time available. In weightless environments convective spread is abolished but it is likely that nap propagation will be unaffected so one cannot draw comfort in this direction.

Flameproofing processes slow or stop spread over the nap of clothing but it may still occur in the hair of skin underneath proofed fabric. It is possible though not proven that this process may liberate sufficient energy to blister the skin it passes over and to ignite the material it travels beneath. Tight clothing can prevent this.

Methods of Extinction

Oxygen enriched fires cannot be put out by any form of fire blanket largely because of the lack of inert gas, and to attempt it would be a disastrous waste of the short time available. (The same is true, though to a lesser extent, of fires in compressed air.)

Conventional water sprinkler systems cannot extinguish these fires either but it is now known that they can be put out by water sprays providing these meet stringent flow and density requirements and are automatically rather than manually operated (Denison, Ernsting and Cresswell 1965; Pignatelli 1965). Because the water volume needed is large this method cannot be used in flight.

A team of investigators at Brooks Air Force Base have developed an automatic system which employs a battery of pressurized bombs filled with the refrigerant bromo-tri-fluoro methane (Freon 1301). A signal generated by the first flash of fire is used to rupture bursting discs on the bombs and the Freon is released in time to stifle events before the main fire develops (Eggleston 1967). Unheated Freon 1301 can be respired with little ill-effect but the toxicity of the pyrolysed vapour is disputed and this may limit use of the system.

No other methods of extinction are known at present. Methyl bromide is flammable in oxygen and carbon dioxide is both ineffective and dangerous. Because the energetics of flash fires are unknown the results of extinguisher tests must be interpreted with caution (see Proc NASA-USAF Symposium).

The Problems of Hyperbaric Oxygen Therapy

Experiments on both sides of the Atlantic have shown the dangers of fire are very much smaller in compressed air than in

oxygen. At Farnborough we believe hyperbaric oxygen therapy should be given by oronasal mask in a compressed air chamber unless a conclusive case can be made against it. Such cases are probably restricted to those occasions when one hopes to oxygenate an ischaemic area of exposed tissue, not deeper than 2 mm from the surface. Constructors and users of hyperbaric chambers are reluctant to accept this argument because of the changes involved but it has been shown that the structural modifications required are simple and need not be expensive (Ernsting and Cresswell 1967). No fatal fires have been recorded in therapeutic chambers yet but there is a wish to instrument them which is rising. There will be an inevitable increase in risk as this desire is met.

Codes of practice

Several groups are studying the code of practice needed for the safe operation of oxygen enriched life support chambers of one kind and another and it is likely that their recommendations will follow the pattern set by an interim report published from Glasgow (Lenihan et al. 1967). Meantime these committees have collated much information on the subject which they are anxious both to share and to see extended.

Bibliography

The literature on oxygen enriched fires is already depressingly extensive. A reasonably complete review can be obtained from the bibliography cited in references (3), (5) and (12).

1. Chianta, Maria A. and Alice Stoll (1966). "Effect of inert gases on fabric burning rate." Paper delivered to the 37th Annual Meeting of the Aerospace Medical Association, Las Vegas, Nevada, April.
2. Clamann, H.G. (1965). "Fire hazards." *Annals of the New York Academy of Sciences*, 117, 814-823.
3. Cook, E.G., Meierer, R.E. and B.M. Shields (1967). "Screening of flame resistant materials and comparison of helium with nitrogen for use in diving atmospheres." Office of Naval Research, United States Navy (Contract No N-00014-66-CO149, March).
4. Denison, D.M., Ernsting, J. and A.W. Cresswell (1965). "The fire risks to man, of oxygen rich gas environments." Flying Personnel Research Committee Memorandum 223, Ministry of Defence (Air), London.

5. Denison, D.M. and W.J. Tonkins (1967). "Further studies upon the human aspects of fire in artificial gas environments." Flying Personnel Research Committee Report No 1270, Ministry of Defence (Air), London.
6. Eggleston, L.A. (1967). "Evaluation of fire extinguishing systems for use in oxygen rich atmospheres." Aerospace Medical Division, Brooks Air Force Base, Texas, May.
7. Ernsting, J. and A.W. Cresswell (1967). "An assessment of a modification of a Vickers hyperbaric chamber for pressurization with air and the oronasal administration of oxygen." Royal Air Force Institute of Aviation Medicine Report 417, Ministry of Defence (Air), London.
8. Lenihan, J.M.A. (1967) (Chairman). Report of the Working Party on Fire Hazards in Hyperbaric Environments. Western Regional Hospital Board, Glasgow, June.
9. Proceedings of the NASA-USAF symposium on fire hazards in space vehicles - held at Brooks Air Force Base, San Antonio, Texas, May 1967.
10. Purser, P.R. (1966). "Ignition by electrostatic sparks in hyperbaric oxygen." Lancet ii, 1405-1406.
11. Pignatelli, A.B. (1965). "A rapid response flame detection system." Flying Personnel Research Committee Memorandum 228, Ministry of Defence (Air), London.
12. Roth, E.M. (1964). "Space cabin atmospheres. Pt II Fire and blast hazards." National Aeronautical and Space Administration special publication No 45, NASA Washington DC.
13. Voigtsberger, P. (1962/63). "Die Entzündung von Sauerstoffgetrankten Geweben durch elektrostatische und mechanisch erzeugte Funken. Moderne Unfallverhütung, 7, 66-70.

HUMAN-FACTORS ASPECTS OF ORBITAL OPERATIONS

By A. W. Vogeley

**NASA Langley Research Center
Langley Station, Hampton, Va., U.S.A.**

SUMMARY

This paper presents a comprehensive review of the human-factors aspects of orbital operations required to support a manned orbital laboratory. Based on a detailed operational analysis of what will be demanded of man in such a space system, the paper establishes a reference framework and a set of goals for human-factors research - many of which will require strong biomedical and biotechnological support. Also, since most space station activities require a combination of several specific manual operations, a matrix of these interrelationships is developed. Finally, this matrix is combined with a best-estimate schedule of station activities (heavily dependent upon progress in physical sciences technology) to yield a priority list for human-factors research.

HUMAN-FACTORS ASPECTS OF ORBITAL OPERATIONS

By A. W. Vogeley
NASA Langley Research Center

INTRODUCTION

Establishment of a manned orbital laboratory has been proposed as the next major space goal. The main arguments given are that such a station would be able to (a) contribute to the solution of important earth-oriented problems, (b) study crucial questions in the physical and life sciences, and (c) develop advanced technology for future space exploration. Contained within the above three broad reasons are a large number of individual activities distributed over a number of scientific and technological disciplines that could possibly benefit from a manned space laboratory. All of these, it appears, can be identified as a part or parts of six broad program areas. These six areas are: (1) Astronomy, (2) Earth Resources, (3) Meteorology, (4) Biology, (5) Long-Term Flight, and (6) Research and Development in Advanced Technology.

About 1 year ago the NASA conducted an intensive, interdisciplinary study of each of the above major program areas. This study made full use of the in-house capabilities of NASA and, in addition, drew heavily upon previous studies by NASA Program Offices and Centers, contractors, and other Government groups, including especially those conducted by the National Academy of Science. The purpose of this study was to establish the needs and requirements for a manned space laboratory that would be most responsive to the desires of the six major programs. To support these programs and to develop an operationally effective system concept it was also necessary to develop a parallel Orbital Operations and Logistics Program. In this program logistics is defined as the transport of men and material between the station and the earth base, and orbital operations are defined as space activities which involve man and are performed either to support the basic station or the scientific or technological programs onboard. Although the complete study is unpublished and not available, this paper summarizes orbital operations, or the human-factors aspects of the study.

METHOD OF ANALYSIS

This analysis of the human-factors aspects of orbital operations is based upon a detailed study of the requirements from six broad scientific and technological areas that seem particularly appropriate for space laboratory work. These areas are Astronomy, Earth Resources, Meteorology, Biology, Long-Term Flight, and Research and Development in Advanced Technology. Because separate analyses of the multitudinous activities

required by these programs would be an impossibility, it was necessary to reduce these activities to a more tractable number. This was accomplished by proceeding through four steps that are briefly described below.

1. Classifications

Each major area was first broken down into all of the operations required to support that area. Each operation was then examined carefully to determine whether or not it would be considered as part of this human-factors study according to the following rules:

a. Those operations were retained which, with the present state of the art or in the foreseeable future, can only be done by man. Operations of this sort were found in each of the major areas, so that the availability of man was assumed for the remaining two considerations.

b. Many operations that would probably be performed automatically require or greatly benefit from the attention or intervention of man. These associated manual operations (monitoring, adjustment, repair, etc.) were included.

c. Many operations, if considered independently, could conceivably be done either manually or automatically. In this study, because of the availability of man, manual operation or control was selected for simplicity, flexibility, and reliability.

Finally, analysis of the total number of manual operations found revealed that, if detailed differences were not overemphasized, a great deal of commonality existed and that a much smaller list of basic manual operations could be derived. The end result was that 54 basic manual operations in six categories were identified.

2. Interrelationships

Although it is possible to describe all station activities by a limited number of basic manual operations, it must be remembered that each basic manual operation generally requires support from several other basic operations, if meaningful activities are to result. Because of this important interplay between the various basic operations a matrix showing these interrelationships was developed.

3. Research and Development Programs

Since many of the basic manual operations identified in Step 1 are not within the present state of the art, these capabilities must be acquired either through precursory ground or space research and development, or on the space station itself. This step leads to Human-Factors

BLANK PAGE

Research and Development Programs in each of the six basic manual operations categories.

4. Priorities

For those people who are interested in conducting human-factors research and development related to orbital operations, the programs developed in Step 3 provide convenient "shopping" lists of problems. In selecting problem areas for study, it also seemed desirable to be able to temper any selection with realistic considerations of relative importance and timeliness. For this purpose, the 54 basic operations were finally ordered to form a Priorities Chart.

PRESENTATION AND DISCUSSION OF RESULTS

Charts were selected as the method of presentation of the results of the four-step analysis just described because of the complex interplay of operations for each program or station activity. It would have been impossibly long and redundant to discuss each item separately. Although a narrative approach might be more easily understood, it is felt that summary charts should be sufficient for the informed reader.

Manual Operations Categories

The 54 distinct manual operations in six major categories required to support the activities needed to conduct programs of astronomy, biology, meteorology, earth resources, general research and technology investigations, and long lifetime in space, as well as those activities required to support the basic station itself, are summarized in six charts. Each chart, one for each of the six major categories, lists all of the operations appropriate to the category that were found from a detailed analysis and breakdown of activities and basic station operation. Each chart shows where each operation is required. Appropriate key words or phrases are given whenever an activity, requiring the operation, places special requirements upon station design. In addition, each chart, using these key words, lists the crew skill and the initial and follow-on requirements for station design that are indicated. Under the heading "Remarks," special attention is given to considerations that could not easily be fitted under the other column headings.

To better interpret these and subsequent charts, a few abbreviations are defined as follows:

EVA - extravehicular activity

RMU - remote maneuvering unit

MMU - manned maneuvering unit

LSS - life support system

The six major manual operations are defined and presented in the following sections.

Logistics (Orbital) Operations - Table I

Orbital logistics is defined as the movement or placement (storage, quartering) of material or personnel while in space. It should be observed that this definition has been expanded beyond its commonly understood meaning to include movement of material involved in such activities as replacement or assembly - provided that such activities involve only a rearrangement (bolting, tying, etc.) as contrasted with alteration (cutting, welding, etc.), which is an operation assigned to another category.

Psychophysical Operations - Table II

The psychophysical operations category is concerned with the problems of maintaining and improving the well being or efficiency of man in space. Its first responsibility is to attempt to maintain the effectiveness of man at the level originally expected. Its next responsibility is to attempt to improve the effectiveness of man through study of man "in situ."

Materials Alteration and Transformation Operations - Table III

The materials alteration and transformation category of orbital operations defines activities which are primarily concerned with changes in state that are not easily reversible. This category is best defined by such terms as cutting, soldering, welding, fuel consumption, and digestion.

Guidance and Control Operations - Table IV

The guidance and control category is concerned with the process of directing the transfer of material from one location to another. This direction may be applied by either manual power or by the remote control of power.

Communications Operations - Table V

The communications category of operations is concerned with all activities associated with the reception, transmission, modification, or storage of information.

Safety and Reliability Operations - Table VI

Operations in the safety and reliability category, related primarily to safety, are those which are designed to preserve predetermined, acceptable standards of safe operation or to minimize the deleterious effects of departures from these standards because of such factors as failures, accidents, or mistakes, and/or other unusual, unanticipated, or infrequent circumstances.

In concluding this presentation of the six basic categories of manual orbital operations, it should be pointed out that these same six categories encompass and define the human-factors Research and Development Programs that must be carried out to support a manned space station from inception to eventual full development.

Interrelationships

A matrix showing the interrelationship between space station operations is presented in Table VII. In this chart the letters A, B, C, etc., correspond to the operations categories of Tables I, II, III, etc., and the numbers refer to specific basic operations under each main category. The chart is to be interpreted in the following manner: For example, if the "Operation To Be Performed" is the Logistics Operation A3 (refer to Table I) it is found to require the support of fourteen other manual operations. These are found (by reading down the A3 column) to be Psychophysical Operations B1 and B3, Materials Alteration Operations C1 and C4, Guidance and Control Operations D1, D2, D4, and D7, Communication Operations E3 and E4, and Safety and Reliability Operations F2, F4, F8, and F9.

Research and Development Programs

Six human-factors Research and Development Programs have been developed based upon detailed examination of each of the 54 operations contained in the six operational categories of Tables I through VI. This examination was based on the following considerations:

(1) Is the operation required for initial station deployment or initial operation? Yes or no?

(2) If yes, then the operational capability must be either within the present state of the art or capable of development prior to station deployment. In the latter case, how is the capability to be developed?

(3) If no, can the capability be developed on the ground, or does it require the station as an R and D base? If the latter, how is the R and D to be performed?

The answers to these questions in each of the six major operational areas are summarized in Tables VIII to XIII. Each of these charts outlines broadly the R and D program that appears to be required. In each of these charts, the operations in each program are listed according to the letter/number of the operational requirements found in the corresponding requirements chart of the previous section. (Tables VIII to XIII correspond to Tables I to VI, respectively.) In each chart, the second column indicates whether or not the operation is required for initial station deployment or operation. For some of these operations, it should be noted, initial station deployment requires only a limited capability, with enlarged capability (required to support follow-on station activities) requiring R and D in orbit.

The R and D programs are presented separately below with a brief discussion of those program elements of particular interest.

Logistics (Orbital) R and D Program - Table VIII

Thirteen basic orbital operations were listed in the earlier chart of logistics (orbital) operations requirements (Table I). Nine of these operations (denoted by "yes" in the first column of this R and D program chart) are initial requirements for the operation of a long-term manned space station. Five of these nine operations fall within the present state of the art and all can be prescribed for initial operations.

Four of the operations that are most important to the successful future use of a long-term space laboratory (A3, A10, A11, and A12) are not fully developed state-of-the-art capabilities. Although water-immersion earth simulations and precursory space experiments will permit initial operations, the terminal R and D programs for these four operations appear to require the environment of a space station. These four operations are discussed separately in order of importance.

A3: The movement of solids through air locks is an operation that is particularly urgent to all-around housekeeping of a space laboratory, and many experiments will require this technique in a high degree of development. Examples are remote zero-g experimental packets and small remote telescopes. Early space R and D of this problem could be conducted using an iris inside a vehicle to represent an air lock, learning to move nonsensitive or well-padded masses

through this mock-up, then progressing to more critical cases. The attendant use of tethers and restraints would also be developed as necessary.

A10: The removal and replacement of parts is a vital maintenance function that sets the manned space station apart from an unmanned complex which cannot exploit this procedure to sustain its operations. Earth simulation through water immersion and Gemini EVA experiments have thus far provided only superficial information of part tasks and are totally inadequate for the R and D of this maintenance operation involving larger parts or tasks requiring long times to complete.

The initial capability must exist for the replacement of small, ordinary parts. A space R and D program would extend this capability to include size extremes (large or very small parts), delicate or precision parts, and the problems associated with accomplishing these tasks in a space-station environment.

A11: The onboard assembly of small delicate and/or high-precision instruments and equipment is another requisite that cannot be developed in earth-bound laboratories or on short-lived zero-g airplane flights. Equipment that cannot be launched fully assembled dictates a space flight R and D program to develop jigs, fixtures, and assembly methods.

A12: The assembly of larger masses involves equipment whose pre-launch assembly is inconvenient because of packaging or impossible because of delicate structures that could not be self-supporting in one or more g's. An R and D program of practicing the assembly and handling of such expendable items as empty tanks or containers would serve to develop the required capability.

Psychophysical R and D Program - Table IX

Of the six requirements set forth for psychophysical operations in a long-term space laboratory, the first three are initial requisites while the three involving maintenance of proficiency, physical conditioning, and recreation might best be developed after orbital operations begin. The R and D program chart (Table IX) is self-explanatory; however, two of the six requirements will have a profound influence on successful space-station development and use. These two (B2 - medical treatment, including diagnosis, and B4 - maintenance of proficiency) are singled out:

B2: Although present methods for first-aid treatment are adequate for initial space-station operations, a comprehensive R and D program to study the diagnosis and treatment of men and animals in space is both desirable for ensuing emergencies that will no doubt occur at some time during the life of a space station and, more

important, it is essential in the case of the man if he is to survive and become efficient during long-term flights where emergency reentry is not available. This R and D program will require a complete reexamination of diagnostic procedures, treatment, and surgical techniques as they are affected by the space environment - in particular, the effects of partial pressure and zero g.

B4: This maintenance-of-proficiency requirement is primarily piloting, and its greatest impact on station operations will occur in areas involving activities such as the reentry control of high-performance logistics vehicles. The R and D program would require onboard simulation that includes both the vehicle control tasks and the high-g loading (centrifuge) on the pilot. To be effective, this R and D program would compare results between pilots - one who had been through the maintenance-of-proficiency program and one who must rely on retention of his previous skills. By varying the cycle frequencies, a near-optimum schedule of operations for skill retention could be derived for both long-term space-station operations and future interplanetary missions.

Materials Alteration and Transformation R and D Program - Table X

Five operations are prescribed for a long-term space station that involve some generally irreversible process such as fabrication, digestion and elimination, or the processing and expending of materials. The R and D chart (table X) denotes by "yes" that the accommodation of nutrition, propulsion systems operations, and hygiene is an initial requirement; whereas, materials fabrication and data processing are flight-operations requirements amenable to orbital R and D. Attention is directed to C1 (fabrication) which is most important to successful long-term operations:

C1: Fabrication and repair as envisioned here incorporates a self-reliance that can eliminate, to a large degree, the requirement for replacing a part or complete module that can be repaired by soldering, riveting, et cetera. The R and D program to support this operation must include, to a high degree, the application of standardized materials and equipment. The program should consider the use of spent boosters and resupply tanks as raw material for training. Another important area of development is that of special tools - with special considerations for EVA. The handling and disposal of waste is an important R and D requirement to insure against contamination and safety violations.

Guidance and Control R and D Program - Table XI

Eleven guidance and control (G and C) operations are identified for a long-term space laboratory. Three, personnel movement in and around the station (D2(a), D2(b), and D2(d)), rendezvous (D3), and earth-return

launch (D5), are considered essential for initial deployment. The R and D program chart sets forth the precursory and onboard R and D requirements for the eleven operations, and is self-explanatory.

Communications R and D Program - Table XII

Ten communications operations are identified. The first six operations are required for initial deployment. In addition to these, data compression and data analysis techniques are important R and D requirements. Particular attention is focused on data compression. This operation will be important to all efficient long-term laboratory uses in order to reduce the amount of data, photographs, and film requiring physical station-to-earth transmission.

Safety and Reliability R and D Program - Table XIII

Sufficient knowledge exists in all nine operations of the safety and reliability program to permit initial deployment of a space station. Onboard research is essential for support of manned operations connected with continued space-station activity. This research is mainly in the establishment and practicing of procedures. The fact that the research itself must be done in a safe manner means that some safety operations are required for support of other safety operations.

Priority of R and D

An important adjunct to the six major R and D program charts is the Priority Chart (Table XIV). This chart was evolved from considerations of each manual operation in the light of its required support operations (found in the Interrelationships Chart of Table VII) and from estimates of the pace of technological progress in each of the major activity areas (Astronomy, Biology, etc.).

As the chart shows, four levels of priority can be established. The first level lists those operations that must be initially available for space station deployment. This is followed by three phases of R and D requiring the space station itself or, at least, rather sophisticated precursory space flights. (First-phase objectives must be accomplished before second-phase R and D can be initiated, etc.) It should also be noted that the operations under each level of priority have themselves been listed in order of priority.

SUMMARY REMARKS

Detailed analysis of the human-factors aspects of six broad scientific and technological space station programs has revealed that the

capability to perform 54 basic manual orbital operations in six main categories must be acquired. To develop these capabilities, six human-factors R and D Programs have been outlined and priorities have been determined.

Some significant conclusions that can be drawn from analysis of the 54 required operations are:

(1) Thirty-four manual operations are required for initial space station deployment, some of which are within the present state of the art. All operations which are not presently state of the art are amenable to precursory R and D.

(2) Five operations demanding only a limited, initial capability are required for initial deployment. This limited capability is available or can be developed. Extended capability in these five areas to support follow-on station activities must be developed with in-space R and D programs.

(3) Fifteen very important operations, although not initially required, must have the space station or the space environment for R and D.

TABLE I
 REQUIREMENTS CHART A - LOGISTICS (ORBITAL) OPERATIONS

Operations	Basic station				Activities generating requirements							Station design requirements			
	Equipment	Crew	Astronomy	Earth resources	Meteorology	Minimal	Long-term flight	F and D in advanced technology	Special skills	Initial equipment	Follow-on equipment	Remarks	Station design requirements		
													Short-term flight	Special skills	
A1. Crew replacement Regular schedule Flexible schedule	Yes Yes	Yes Yes	Yes Yes	Yes Yes	Yes Yes	Yes Yes	Yes Yes	Yes Yes	Yes Yes	Large ferry Small ferry					
A2. Inventory control	Yes		Yes	Yes	Yes	Yes	Yes	Yes	Statistical	Quantity-measuring equipment Data handling					
A3. Movement of solids through air locks	Yes	Yes	Small remote telescope	Yes	Yes	Zero-g remote mobile	Yes	Yes	Ion engines Gyro Sensors	Air lock Locking hatch				Small modules will be serviced onboard	
A4. Transfer of liquids	Yes	Life support	RFI fuel	Probe fuel	Probe fuel	RFI fuel	Life support	Hydroponics	Yes	Pumps Containers					
A5. Transfer of gases and cryogenics	Yes	Life support					Life support	Closed-cycle life	Yes	Pumps Container				Effectiveness of partial g must be investigated	
A6. Transfer of radioactive materials	Yes	Nuclear power					Irradiation experiments		Power system development Irradiation experiments	Shielding Mediation enclosure					
A7. Storage	Yes	Quarters Perishables	Yes	Yes	Yes	Animal quarters Perishables	Yes	Yes	Positive restraint quarters	Separated quarters					
A8. Transfer and storage of international logistics	Yes	Orbit change Station mapping	Remote detached orbital	Extra- orbital	Extra- orbital	Zero-g irradiation experiments	Zero-g irradiation experiments	Yes	Piloting Navigation Propulsion	RFI					
A9. Remote manipulation of equipment	Yes	Telescope pointing File changing	Yes	Yes	Yes	Specimen handling	Closed- loop cycle	Yes	Piloting	Remote manipulators					
A10. Maintenance of small and replaceable parts	Yes	Yes	Yes	Yes	Yes	Yes	Yes	Yes	Mechanical	Tools Jigs Work shop Shirt-sleeve environment Assembly volume				Effectiveness of partial g must be investigated	
A11. Construction (assembly onboard)	Yes	Small telescope	Small telescope	Sensors Camera	Sensors Camera	Zero-g module	Yes	Yes	Mechanical	Tools Tapes Methods Attachment points				Safe reentry capability required	
A12. Construction Assembly ITH	Yes	Solar panels Antennas	Large telescopes	Probes	Probes	Long-term vehicle	Yes	Yes	Mechanical	RFI Mediation tools					
A13. Waste disposal Organic Inorganic Radioactive	Yes Yes Yes	Yes	Yes	Yes	Yes	Yes	Yes	Yes	Contamination control Cleaning Disposal Containment Control	Contamination control Cleaning Disposal Containment Control					

TABLE II

REQUIREMENTS CHART B - PSYCHOPHYSICAL OPERATIONS

Operations	Basic station				Activities generating requirement				Station design requirements				Remarks	
	Equipment		Crew		Astronomy	Earth resources	Neuro-ology	Bio-medical	Long-term flight	R and D in advanced technology	Special skills	Initial equipment		Follow-on equipment
	Yes	No	Yes	No	Yes	No	Yes	No	Yes	No	Yes	No		
B1. Medical monitoring	Yes		Yes				Yes		Yes	Medical	Medical instruments			
B2. Medical treatment	Yes		Yes				Antibiotics	Yes		Medical	First aid	SUGGEST		
B3. Psychophysical monitoring	Yes		Yes				Personality	Yes		Psychology	Test console		Set up efficient work rest cycles, time-line analysis, crew replacement schedules	
B4. Psychomotor performance	Yes		Yes					Yes			Data storage			
B5. Maintenance of proficiency	Yes		Yes					Yes			Reentry simulator		Piloting particularly important	
B6. Physical conditioning	Yes		Yes					Yes			Exercise			
B7. Recreation	Yes		Yes					Yes			Games			
											Books			
											R-FI			

TABLE III

REQUIREMENTS CHART C - MATERIALS ALTERATION AND TRANSFORMATION OPERATIONS

Operations	Basic station				Activities Generating Requirements				Station Design Requirements				Remarks
	Equipment	Crew	Astronomy	Earth resources	Neuro-ology	Bio-medical	Long-term flight	R and D in advanced technology	Special skills	Initial equipment	Follow-on equipment		
C1. Fabrication and repair of tools, processes as cutting, sewing, soldering, riveting, and welding	Yes		Yes	Yes	Yes	Yes	Yes	Yes	Yes	Mechanical tools Medical Electronics Optics	Special tools for EVA use	Effects of artificial environment should be investigated	
C2. Nutrition		Eating Drinking Elimination				Eating Drinking Elimination	Closed cycle			Food preparation Medical disposal Waste disposal		Usefulness of artificial environment should be investigated	
C3. Data processing - Photography	Yes	Yes	Yes	Yes	Yes	Yes		Yes	Yes	Film development Splicing Projecting Tape making Splicing Etc.			
C4. Propulsion systems		Monitoring	Film production	Film production	Film production	Specimen monitoring experiments	Nuclear power	Radiation experiments		Sensitive film and apparatus			
	Attitude Translation Resupply vehicles	Resupply vehicles	RHE Probe	RHE Probe	RHE Probe	RHE Probe		Yes	Yes	Fuel tanks Fer and storage Facilities Exhaust products		Contamination of external equipment by exhaust is a problem	
C5. Systems		Personal hygiene				Animal hygiene	Closed cycle			Hygienic facilities			

TABLE IV

REQUIREMENTS CHART D - GUIDANCE AND CONTROL OPERATIONS

Operations	Basic station				Activities generating requirements							Station design requirements				
	Equipment	Crew	Astronomy	March resources	Microscopy	Biomedical	Complete flight	F and D in advanced technology	Special skills	Initial equipment	Follow-on equipment	Remarks				
													Yes	No	Remarks	
21. Management and servicing of space-station activities	Yes	Yes	Yes	Yes	Yes	Yes	Yes	Yes	Commander Operations engineer	Computer						
22. Personnel movement																
(a) Inside station		Yes	Yes	Yes	Yes	Yes	Yes	Yes		and mids JOL holds	Gravity stability	For both zero and partial g				
(b) Outside station	Inspection and repair	Inspection and repair	Grasping	Grasping	Grasping	Grasping	Grasping	Grasping		and holds		Ready system, remote capability required				
(c) Needs to station	Large tele-scopes	Large tele-scopes	Large tele-scopes	Grasping	Grasping	Grasping	Grasping	Grasping	Piloting Mechanical	Personal propulsion with tethers	MEI	Measure of remote assembly capability required				
(d) Through air lock	EVA	EVA	EVA	EVA	EVA	EVA	EVA	EVA	MEI	Air locks						
23. Redundant support of vehicles	Yes	Yes	Yes	Yes	Yes	Yes	Yes	Yes	Piloting Navigation	Control station Tracking equipment						
24. Manual movement of materials into and out of station	Liquids Solids and gas of gases	Yes	Yes	Yes	Yes	Yes	Yes	Yes		Heavy object restraining		Present state of the art suggests "heavy" is more than 50 pounds				
25. Orbital launch of earth-return vehicle	Supply vehicle waste	Ins	Ins	Data	Specimens	Specimens	Specimens	Specimens	Piloting	Launch pads	MEI					
26. Station keeping of material		Remote tele-scopes	Remote tele-scopes	Remote sensors	Remote sensors	Remote sensors	Remote sensors	Remote sensors	Piloting	Control station	MEI	Includes tracking (radio antenna, radio antenna, etc.)				
27. Control of artificial g	Yes	Yes	Yes	Yes	Yes	Yes	Yes	Yes	Piloting	Artificial g system		Identified as a problem & sufficient				
28. Remote control relocation of material	Orbit change (per. 4) reassembly vehicle	Remote tele-scopes	Remote tele-scopes	Remote probes	Remote probes	Remote probes	Remote probes	Remote probes	Piloting Navigation	Control station	MEI	Unmanned remotely required for contingencies				
29. Remote control relocation of equipment	Solar panels (per. 4) Antenna	Small tele-scopes	Small tele-scopes	Small tele-scopes	Small tele-scopes	Small tele-scopes	Small tele-scopes	Small tele-scopes	Piloting	Control station	Control station					
30. Manual manipulation of material, remote		Large tele-assembly	Large tele-assembly	Large tele-assembly	Large tele-assembly	Large tele-assembly	Large tele-assembly	Large tele-assembly			MEI	Detached MEI operations require remote capability				
31. Orbital control of earth-orbital vehicles		Synchronous orbit telescopes	Synchronous orbit telescopes	Probes	Probes	Probes	Probes	Probes	Navigation	Control station Navigation computer	Space-attach equipment					

TABLE VI

REQUIREMENTS CHART F - SAFETY AND RELIABILITY OPERATIONS

Operations	Activities associated requirements				Special design requirements				Remarks		
	Basic station Equipment	Crew	Astronomy	Earth resources	Metereology	Biomedical	Long-term flight	E and C in advanced technology		Special skills	Intra: equipment equipment
P1. Rescure		Evacuate crew	From remote telescopes			From remote module		From remote experiments	From remote piloting		W/E with rescure ability
P2. Monitoring of life-support systems		Crew protection				Experiments or genuine	Yes			Sensors warning devices	
P3. Equipment checkout	Emergency vehicles	Pressure suits	Yes	Yes	Yes	Yes	Long-term storage tasks	Yes		Equipment for attached operations	
P4. Monitoring operations in hazardous environment	Equipment protection	Crew protection	EVA	EVA	EVA	EVA	Yes	EVA		Emergency pressure suits buddy system	Must be scheduled
P5. Rescure		Active crew	From EVA	From EVA	From EVA	From EVA	Yes	From EVA	Piloting	Emergency vehicles medical retrieval system	
P6. Damage control	Yes	Yes					Yes	Yes		Damage isolation shuts	Fire control contaminant control
P7. Damage repair	Yes	First aid	Yes	Yes	Yes	Yes	Yes	Yes	Mechanical Medical	Mechanics Electrical denture	
P8. Monitoring use of hazardous materials	Fuels	Crew protection				Radioactive material	Yes	Radioactive material		Buddy system Sensors	Must be scheduled
P9. Radiation monitoring, general	Semiconductor protection	Crew protection	Film protection	Film protection	Film protection	Animals and plants	Yes	Film	Mediology Electronic	Sensors Warning device	

TABLE VII

INTERRELATIONSHIPS BETWEEN SPACE STATION OPERATIONS

Operation to be Performed

The diagram is a large grid with 6 main sections, labeled A through F on both the vertical and horizontal axes. The vertical axis is labeled 'Support Operation' and the horizontal axis is labeled 'Operation to be Performed'. Each section (A-F) contains 10 numbered rows and 10 numbered columns. Small circles are placed in various cells across the grid, indicating dependencies or relationships between the operations in different sections. For example, in section A, circles are present in cells (A1,1), (A1,2), (A2,1), (A2,2), (A3,1), (A3,2), (A3,3), (A4,1), (A4,2), (A4,3), (A4,4), (A5,1), (A5,2), (A5,3), (A5,4), (A5,5), (A6,1), (A6,2), (A6,3), (A6,4), (A6,5), (A6,6), (A7,1), (A7,2), (A7,3), (A7,4), (A7,5), (A7,6), (A8,1), (A8,2), (A8,3), (A8,4), (A8,5), (A8,6), (A8,7), (A8,8), (A8,9), (A8,10), (A9,1), (A9,2), (A9,3), (A9,4), (A9,5), (A9,6), (A9,7), (A9,8), (A9,9), (A9,10), (A10,1), (A10,2), (A10,3), (A10,4), (A10,5), (A10,6), (A10,7), (A10,8), (A10,9), (A10,10). Similar patterns of circles are distributed across sections B, C, D, E, and F.

TABLE VIII

R AND D PROGRAM CHART A - LOGISTICS (ORBITAL) OPERATIONS

Operation from requirements Chart A	Required for initial deployment	Precursory R and D	Onboard R and D	Remarks
A1	Initial schedule Yes	Interim orbital flights Submarine Isolated simulations	Setup work-rest cycles, crew replacement schedules, and time-line analysis for activity scheduling	Psychophysical monitoring to establish optimum schedule
A2	Yes	State of art		
A3	Yes	Water-immersion tests, Gemini Apollo	Progressive increase in size and mass of objects moved	Small remote telescope probably critical
A4	Yes	State of art	Experiment with water, transferring from resupply vehicle to empty resupply containers; investigate effects of partial g	Onboard program for large-quantity transfer
A5	Yes	Gemini and Apollo experience sufficient for initial requirement	Follow-on not defined	
A6	No	Nuclear submarine ABC experience	None presently foreseen	Basic technology available; support operations are critical (see chart of interrelationships)
A7	Yes	Gemini Apollo Biosatellites	None presently foreseen	
A8	Yes	Gemini Ground simulations	Operation of extracorbital probes requires development	Primarily guidance and control operation
A9	No	ABC experience	Development only necessary for special applications	Amenable to ground simulation
A10	Yes	Gemini Water-immersion tests	Progressive increase in size and complexity	Ground simulation inadequate for large assemblies
A11	No	No adequate zero-g simulation facilities available	Handling and adjustment of small, delicate precision equipment requires onboard development	Most research activities require earliest possible development of this operational capability
A12	No	Ground facilities inadequate	Space-station EVA simulations using empty resupply containers	
A15	Yes	State of art	None presently foreseen	Basic technology available; support operations are critical

TABLE IX

R AND D PROGRAM CHART B - PSYCHOPHYSICAL OPERATIONS

Operation from requirements Chart B	Required for initial deployment	Precursory R and D	Onboard R and D	Remarks
B1	Yes	State of art		
B2	Yes	State of art adequate for first-aid treatment	R and D into diagnostic procedures and treatment beyond first aid in space environment (zero G, low pressure, etc.) required for emergencies	Onboard R and D essential to long-term missions
B3	Yes	Monitoring procedures are state of art	Set up work-rest cycles, crew replacement schedules, and time-line analysis for activity scheduling	This operation essential to continued operation of station
B4	No	Ground-based simulations Apollo	Requires well-planned validation program	Essential development for long-term missions and where highly maneuverable reentry vehicles to be used
B5	No	Ground simulation of inactivity (not adequate for zero-g effects)	Develop exercise schedule for efficiency	Medical and psychological monitoring essential to this operation
B6	No	State of art, personal preference of crew	Develop to suit crew personalities	Primarily dependent on psychological monitoring; affects activity scheduling

TABLE X
R AND D PROGRAM CHART C - MATERIALS ALTERATION AND TRANSFORMATION OPERATIONS

Operation from requirements Chart C	Required for initial Deployment	Precursory R and D	Onboard R and D	Remarks
C1	No	Ground-based development of tools and techniques (ground-developed techniques probably not adequate for EVA)	Validation and development of ground-based R and D is essential, zero and partial g to be investigated and compared	Waste disposal is important consideration
C2	Yes	State of art sufficient nutritionally	Develop methods of preparing meals to meet psychological needs of crew	Psychophysical monitoring essential to onboard R and D
C3	No	State of art	None presently foreseen	Affects scheduling of activities; waste disposal important
C4	Yes	State of art	Program to control contamination by exhaust	
C5	Yes	State of art	Develop hygienic routines; partial g may be important	Psychophysical monitoring required

TABLE XI

R AND D PROGRAM CHART D - GUIDANCE AND CONTROL OPERATIONS

Operation from requirements Chart D	Required for initial deployment	Precedency R and D	Onboard R and D	Remarks
D1	No	Gemini and Apollo Ground-based simulations Operations analysis	Time-line analyses	Initial scheduling must be feasible as ground-based analyses are not realistic
D2(a)	Yes	State of art	Study gravity substitutes (veloc, etc.) Psychophysical effects of partial G	
D2(b)	Yes	Gemini and Apollo Water immersion State-of-art use of manholds and tethers	Improvements of efficiency through or not R and D required	
D2(c)	No	Ground-based simulation to develop RND and MND hardware	Develop simpler MND's and G and C techniques	This operation depends completely on prior development of adequate rescue facilities and techniques
D2(d)	Yes	Gemini Apollo State of art		
D3	Yes	State of art based on ground simulations		
D4	No	Water immersion	Develop efficient and safe restraints, guides, etc.	This operation applies to very heavy objects which are subject to damage or may cause damage if not properly controlled
D5	Yes	Gemini and Apollo State of art		
D6	No	Ground-based simulations Development of RND	Develop techniques for multiple remote station control	
D7	No	Ground-based simulation Development of hardware and techniques	Validation of ground-developed techniques	Capability for intermittent artificial G is an initial design requirement
D8	No	Ground-based simulation Development of RND and sensors for autonomous navigation	Develop remote-control techniques	
D9	No	ABC experience Ground-based simulation	Now presently foreseen	
D10	No	Ground-based simulation	Develop simpler MND's and G and C techniques	Adequate rescue facilities must be developed first
D11	No	Ground-based simulation Development of techniques	Experiments with dummy payloads or expendable research payloads; (an adequate probe whose function does not require a probe station) is ideal as experimental vehicle for this operational research)	Primary concern of space station is launch and return; short-range guidance and control; adequate rescue facilities; adequate recovery ground stations

TABLE XII

R AND D PROGRAM CHART E - COMMUNICATIONS OPERATIONS

Operation from requirements Chart E	Required for initial Deployment	Precursory R and D	Onboard R and D	Remarks
E1	Yes	State of art except possible bandwidth limitation	None presently foreseen	The first eight operations are regarded as "state of the art" with respect to communication equipment requirements
E2	Yes	State of art	None presently foreseen	
E3	Yes	State of art	None presently foreseen	
E4	Yes	State of art	None presently foreseen	
E5	Yes	State of art	None presently foreseen	
E6	Yes	State of art	None presently foreseen	
E7	No	State of art	None presently foreseen	
E8	No	State of art	None presently foreseen	
E9	No	Ground-based simulation Computer studies	Develop techniques for selecting photos to be transmitted for maximum efficiency of earth resources and meteorology studies	Particularly important, because of high data rate expected, for conservation of bandwidth
E10	No	Computer studies	None presently foreseen	

TABLE XIII
R AND D PROGRAM CHART F - SAFETY AND RELIABILITY OPERATIONS

Operation from requirements Chart F	Required for initial deployment	Precursory R and D	Onboard R and D	Remarks
F1	Yes	Gemini and Apollo, Ground-based simulation, Design of MMU with reentry capability	Experiments with unmanned MMU (remote controlled) to validate design	Remote control of MMU required in any case
F2	Yes	State-of-art hardware Ground-based simulation of techniques	None presently foreseen	
F3	Yes	Gemini and Apollo Ground-based simulation and development of equipment to allow use of space station power for checkout	None presently foreseen except scheduling of periodic checkouts	
F4	Yes	Gemini and Apollo AEC experience Ground-based simulation	None presently foreseen except scheduling of hazardous operations	
F5	Yes	Ground-based development of techniques for rescue from unattached EVA, tethered EVA, escape from space station	Escape drills Validation or modifications of rescue techniques by experiments with dummies	Remote control of MMU required in any case
F6	Yes	Ground-based development of techniques and fire-control equipment	Rehearse emergency purge of space station atmosphere and use of isolation doors	
F7	Yes	Ground-based development of warning devices, tools, and procedures	Parallel development of fabrication and repair and management and scheduling of space station activities	
F8	Yes	State of art		
F9	Yes	State of art		

TABLE XIV

PRIORITY CHART - ORBITAL OPERATIONS R AND D PROGRAMS

Initially available or within state of the art	1st phase of R and D	2nd phase of R and D	3rd phase of R and D
A1 A2 A3* A4 A5 A7 A8 A9 A10* A13	D3 D4 (extended) C4 C3 D7 A11	B4 C2 C5 B5 B6 A12	D2 (extended) D6 D5 D11
B1 B2* B3	D10 D8 D6	F5 (EVA)	
C3 C4 C5	A6 A3 (extended) A10 (extended)		
D2* D3 D4* D5 D9	B2 (extended)		
E1 E2 E3 E4 E5 E6' E7 E8 E9 E10	C1 D1 F7		
F1 F2 F3 F4 F5 F6 F8 F9			

* Extended R and D required.

**STATUS REPORT ON RECENT LANGLEY STUDIES OF
LUNAR AND SPACE STATION SELF-LOCOMOTION**

By Donald E. Hewes

**NASA Langley Research Center
Langley Station, Hampton, Va., U.S.A.**

SUMMARY

Studies of the self-locomotive capabilities of astronauts both on the lunar surface and in rotating space stations are currently being carried out by the Langley Research Center of the National Aeronautics and Space Administration. New and unique reduced gravity simulators developed for this work permit subjects to experience and report firsthand on the sensations and physical effects produced by the space environments. This paper is a brief status report on some aspects of this work and includes general descriptions of the facilities employed, the types of studies underway, and some observations and comments based on results obtained up to this date.

The lunar locomotion studies are being carried out both by in-house effort and by contract with aerospace industries using an inclined-plane technique developed at Langley for simulating lunar gravity. The initial in-house studies revealed that there were significant differences between earth and lunar locomotive gait characteristics and that in general a gravity level equal to that of the moon had a favorable effect on these locomotive capabilities. These results are being borne out by contracted studies which are investigating in greater detail the effects of the various lunar environmental factors.

The space station studies utilize a Langley developed simulator capable of rotation which together with the inclined-plane technique adapted from the Lunar Walking Simulator can provide weightless and rotational conditions of these studies. It was observed that subjects could initiate and sustain a walk at gravity levels below 0.2 times earth's gravity. In addition to walking, "space soaring" could be employed under these conditions. Use of the hands and arms was found to be advantageous under these conditions. At higher gravity levels, above 0.2 to 0.3 times earth gravity, an annoying effect due to centrifugal forces imposed on the legs as they swung forward in the walking stride was noted. This effect caused the legs to feel excessively heavy but did not prevent locomotion.

STATUS REPORT ON RECENT LANGLEY STUDIES OF

LUNAR AND SPACE STATION SELF-LOCOMOTION

By Donald E. Hewes
NASA Langley Research Center

INTRODUCTION

The desire and need for placing man into space, whether in a spacecraft or on some extraterrestrial body, is based on his ability to think, to observe, to reason, to manipulate, and to locomote. Because of these characteristics, he should be able to perform many functions which cannot be effectively performed by machines. Of course, one of the basic concerns about space is the question of how well man will be able to utilize these characteristics developed through millions of years of evolution in earth's gravitational field in the weightless and near weightless space environments. Some of the research efforts of the Langley Research Center of the National Aeronautics and Space Administration have been directed toward one aspect of this question, namely, the study of man's self-locomotive capabilities in space. This report will review briefly the progress which has been made to date and plans for continuing work relative to man in a rotating space station and to man on the lunar surface. New and unique reduced gravity simulators developed for this work permit test subjects to experience firsthand the sensations and physical effects essentially equivalent to those produced by space environments. These studies are, of course, directly related to the Apollo lunar mission and to future missions with orbital space stations.

LUNAR SELF-LOCOMOTION

Efforts related to the lunar locomotion field at the Langley Research Center were started several years ago with the development of the Lunar Walking Simulator employing the so-called inclined-plane technique reported in reference 1. Briefly, in this technique the subject is supported, as shown in figure 1, on his side by a series of cables attached to an overhead monorail trolley system running parallel with an inclined walkway on which the subject can walk, run, crawl, and jump. The walkway is displaced from directly beneath the monorail track so that the subject's vertical axis, that is, along his backbone, as shown in figure 2, is inclined about 9.6° from the horizontal, thus aligning the subject with a component equal to one-sixth of the earth's gravity vector. Although this suspension restricts body movement to essentially planar motion, very realistic results can be achieved with only minimal interference caused by the suspension system.

BLANK PAGE

Several studies have been carried out under Langley's direction using this technique and are discussed in references 1 through 7. Currently an extensive study, contracted by Langley to the AIResearch Division of the Garrett Corporation at Los Angeles, California, is underway to determine the restraints imposed by specific features of the lunar terrain on the astronaut's capabilities. This work is an expansion of that previously carried out under a Langley contract by the Northrop Space Laboratories as reported in reference 6.

A basic understanding of man's self-locomotive capabilities on the moon can be developed from figure 3 which represents the significant results of some early work reported in reference 4 in terms of stepping rate, in steps per second, plotted against locomotive velocity, in meters per second, achieved under the test conditions. The solid line corresponds to the general trend of data points obtained with three subjects of differing stature wearing conventional flying coveralls while walking and running in earth gravity on a smooth firm surface; the dashed line corresponds to the same test performed in simulated lunar gravity. The termination of the lines indicates the maximum running speed for both gravity conditions and the vertical line depicts the transition speeds between walking and running. Comparison of the two curves, therefore, shows that man's maximum walking and running speeds in lunar gravity would be about 60 percent of his earthly capabilities under corresponding conditions. These results are attributed primarily to his reduced weight and consequent loss of foot traction.

Perhaps, of far more importance than this loss of speed capability is the very significant reduction in the number of steps per second required for a given locomotive speed for the lunar condition. This comes about by the ability to take a longer stride in the lunar gravity condition. Note particularly the disparity between the two curves in the speed region of 2 to 3 meters per second where the lunar stepping rate is essentially one-half of the terrestrial rate. If we, logically, relate energy expenditure to stepping rate, the energy costs of lunar self-locomotion can be seen to be markedly less than those related to our earthly experience. The implication here is that in spite of the apparent performance loss due to reduction of speed capabilities on the moon there may be a significant performance gain in terms of energy expenditure and optimum speed of locomotion.

These observations have been borne out by the subsequent work performed in the contract study reported in reference 6. Here two pressure-suited subjects with 32.7-kilogram (72-pound) life-support backpacks performed similar tests while wearing obsolete, but commonly used, Mark IV pressure suits. Some of the data were presented and analyzed in reference 7, from which figure 4 was obtained. In this figure, the range or distance in kilometers which can be traveled without fatiguing the astronaut for both gravity conditions is presented for different speeds, in meters per second, and for different time periods, in hours, for a smooth firm surface. There seems to be an even greater disparity between earth and lunar performance than was indicated by the previously

discussed data. This marked difference is due to the effects of the pressure suit and life-support backpack which were found to impose severe penalties in earth gravity but only relatively minor losses in simulated lunar gravity. As a consequence, for any given time period, the lunar explorer can cover about four times the distance as his earthly counterpart assuming, of course, similar conditions. The previously mentioned work currently underway at the AiResearch facilities under Langley direction is expected to expand on these preliminary findings by exploring more fully the effects of surface slope, texture, and bearing strength on the performance of a larger test subject population of six and employing a present-day space suit.

One other aspect of man's self-locomotive capabilities has been explored to some extent in the Langley work, in which various loads up to about 226.8 kilograms (500 earth pounds) were carried on a backpack by subjects wearing conventional flying coveralls in the simulated lunar gravity. The two experienced subjects of average stature and physical condition were able to carry these loads at speeds up to about 4 meters per second, but felt that the 226.8-kilogram (500-pound) load represented the maximum load that they could safely handle. An interesting contrast between earth and lunar load-carrying capabilities was noted when it was observed that a motorized lift truck was required when handling the loaded backpack in preparations for the simulated lunar tests in which the test subjects easily handled the same mass unassisted.

There are, of course, various aspects of the lunar self-locomotion that have not been touched on here but which appear to be more or less self-evident, such as the relative times and distances required to accelerate and decelerate. Perhaps the most significant point to make relative to this subject is that in spite of the markedly different performance capabilities between earth and simulated lunar gravity conditions, the subjects were able to easily adapt to these differences with only brief practice periods.⁽⁵⁾

Rotating Space Station Self-Locomotion

One of the frequently discussed design considerations for space stations is the need for an artificial gravitational environment, and one factor set forth as favoring this need is the requirement for some minimum level of gravity so as to facilitate self-locomotion within the station. To explore the question of the limit value more fully the rotating space station simulator depicted in figure 5 was developed at the Langley Research Center employing the principles of the previously discussed inclined-plane technique and using some of the equipment from the Lunar Walking Simulator. The test subject is supported by a vertical cable so that he is on his side and his normal axis of locomotion is in the horizontal plane wherein the gravity vector is zero. The cable is attached to a trolley unit on a boom-supported monorail; the boom is servo-controlled so as to rotate about the vertical axis of the simulator

and keep the cable directly over the subject as he walks along the vertical wall on the periphery of the circular platform. This wall represents the floor of a space station with a diameter of 12.2 meters.

The platform is designed to rotate about the vertical axis at speeds up to about 17 revolutions per minute, driven by the variable speed electric drive unit supported overhead by the tripod frame straddling the rotating platform. The drive torque is transmitted to the platform through the vertical shaft which supports the monorail-boom unit. The servo-drive unit for the boom is also attached to this vertical drive shaft and is activated by an angle sensor located at the attachment point of the suspension cable for the test subject. This sensor detects deviations of the cable from the vertical caused by motion of the subject relative to the boom.

The geometry of the walkway can be modified from the basic cylindrical shape shown in this figure to one composed of flat walkway surfaces such as a hexagonal or octagonal shape. There also is an inner 6.1-meter walkway with a removable panel so that the test subject can effectively move from one level to another within the station by jumping or climbing a pole, ladder, or stairway which can be easily installed. Figure 6 is a plot of station rotational rate in revolutions per minute versus the gravity level, in earth gravity units (g units), produced by this rotation at the center of gravity of the subject standing on either of the two walkways. Also plotted along the abscissa of the figure is the corresponding tangential velocity of the standing subject. Variation of the rotational speed by an assisting operator can change the gravity level at the outer walkway from 0 to nearly 2 times earth gravity. Of course, the gravity level at the smaller diameter inner floor is correspondingly less.

Difficulties in development of the servo-operated boom have delayed the full utilization of this facility; however, a number of exploratory studies have been carried out to date without the servo-drive unit. In these initial tests, the boom was free to rotate so that it did follow the test subject; however, he was required to overcome the effects of bearing friction, windage, and boom inertia. Inasmuch as for most tests the motions of the subjects were relatively slow and uniform, it is believed that the effects of these forces do not alter the observations drawn from these exploratory tests to any significant degree.

Very interesting results were noted in these tests in which attempts to walk at nominal speeds of about 1 meter per second were made by three subjects, experienced in reduced gravity locomotion. The rotational speed of the space station simulator was adjusted over a range of values from 0 to 12 revolutions per minute, providing gravity levels from about 0 to 1g. Only the larger diameter walkway was used. As might be expected, the ability to initiate the walk decreased essentially proportional to the reduction in gravity level. It was possible to initiate a walk at less than 0.1g; however, the length of time to reach the desired normal walking speed was quite long. Use of the hands and

arms to assist in accelerating the body forward by pulling or pushing on available handholds proved to be very effective in overcoming this problem.

When walking in the direction of rotation it was possible to easily sustain locomotion at very low rates of station rotation. As a matter of fact, it was even possible to sustain a walk at zero rotation corresponding to a weightless condition for the station. For this unique condition, assistance from the hands and arms to initiate the walk was essential. Once some forward momentum was generated by the propelling force of the arms, the feet became effective in producing traction to sustain the walking motion along the curved floor.

Although walking at 0.1g was very comfortable, a rather disturbing sensation was noted for gravity levels somewhere above 0.2g to 0.3g where the legs appeared to become increasingly heavy whenever walking motion was attempted. Although this effect did not prohibit locomotion it did appear to be quite annoying. In one instance, one subject reported the sensation of being heavier than his normal 1.0g weight although the artificial gravity due to station rotation was set at only about 0.5g. Accompanying this sensation was the illusion of increased curvature of the walkway which could be likened to walking at the bottom of a gully or small ravine that seemed to move along with you as you attempted to climb up its side.

Another unusual situation was encountered when attempting to walk in the direction opposite to the station rotation at the lower "g" levels of say 0.1g or less. In this case, as soon as the subjects started walking, they would tend to rise from the floor and float helplessly until they could reach out and grab some part of the station as it rotated past them. This form of locomotion can be likened to the "soaring" which can be employed in the nonrotational space station. As a matter of fact, it was found that at the low gravity levels, below about 0.1g, the soaring form of locomotion was quite effective and perhaps in some instances more desirable than walking regardless of the directional movement. In this type of activity, control of the body attitude is not as effective as for walking and the arms and hands must be employed as well as the feet.

During these tests the subjects undertook some jumping activity in which they attempted to jump perpendicular to the floor in the radial direction so as to grab hold of the "overhead" structural members supporting the inner walkway. This was done in an attempt to obtain a feel for their ability to cope with the Coriolis accelerations engendered by such radial motions. In general, the effects of these accelerations were readily apparent as evidenced by the fact that attempts to jump to a spot directly overhead usually resulted in arriving at a spot displaced several inches from the target in the direction of rotation. Compensation for this effect, however, could be achieved quite easily after a few practice attempts. Therefore, the Coriolis accelerations do not appear to present serious problems relative to this form of locomotion.

Detailed analysis of the observations discussed herein are beyond the scope of this discussion; however, a few brief comments are in order so as to place these observations in their proper perspective. The first comment to be made is that even in the weightless environment with a non-rotational station a gravitational increment is generated by the process of locomotion along the curved floor as illustrated in figure 7, which shows the variation of this gravity level with different walking speeds for the case of the 12.2-meter walkway. If it is assumed that a nominal walking speed of 1 meter per second was maintained in the tests with zero rotation of the station, then this figure indicates that a gravity level of about 0.02g was developed. This then accounts, at least in part, for the ability to walk in the otherwise weightless state. It is noteworthy to point out here, however, that the use of a flat segmented floor rather than the continuously curved floor would have negated this ability to walk in the nonrotational tests inasmuch as the walking would not have generated the necessary curvilinear motion.

Some consideration must be given to the dynamic effects of the walking gait which involved rotational action of the legs. Simple calculations of the additional centrifugal accelerations due to the leg-swing motion were performed to illustrate this point and the results are presented in figure 8, which shows the variation of the calculated total effect of leg-swing motion with the gravity level produced by station rotation. The solid line represents the gravity level experienced by one leg as it swings forward during the half-stride free-swing phase. Inasmuch as the leg represents only about 20 percent of the total body mass, the effect on the body as a whole is less, as depicted by the long-dashed curve. Comparison of these curves with the short-dashed curve reveals the calculated incremental effect due to the leg-swing action. The large incremental accelerations on the leg at the higher gravity levels are undoubtedly the cause of the unusual "heavy-leg" sensation discussed earlier.

The results of walking with and against the direction of station rotation can be explained with the aid of figure 9, showing the variation of the effective gravity level with station rotational rate and equivalent tangential velocity for three conditions: walking with the rotation (long-dashed curve), walking against (short-dashed curve), and standing still (solid curve). This figure is essentially a reproduction of a portion of the curve for the 12.2-meter walkway from figure 6 but with this same curve also shifted along the abscissa by the amount and in the directions equal to the incremental velocity due to walking, which in this case was assumed to be 1 meter per second.

Comparison of these three curves reveals that walking in the direction of rotation has the same effect as does increasing the station tangential velocity or rotational rate. Likewise, walking in the opposite direction has the same effect as does reducing the station rotation. Consequently, walking against the direction of rotation tends to produce the condition of weightlessness on the occupant as was observed in the tests.

One point to make relative to this effect is that a rotating space station may tend to become a natural "one-way street" as far as walking is concerned; that is to say, the occupants may find walking in the direction of rotation to be more natural or comfortable. This could be especially true when they are carrying objects which restrict the use of the hands for assisting locomotion.

REMARKS

Perhaps the most pertinent closing remark to make relative to these two on-going projects that have been discussed here briefly, is that there seem to be significant differences between self-locomotion, involving rectilinear motion, as typified by walking on the moon or in a space station with flat floors, and self-locomotion involving curvilinear motion as in the case of the space station with floors curved about the axis of the rotation. Care should be exercised, therefore, when attempting to speculate on the problems of locomotion in one medium on the basis of experience in the other. Certainly, these few initial observations of self-locomotion in reduced gravity provide some interesting food for thought and point out the need for continuing studies in these areas because of the implications on mission planning, equipment design, and operational procedures.

REFERENCES

1. Hewes, Donald E.; and Spady, Amos A., Jr.: Evaluation of a Gravity Simulation Technique for Studies of Man's Self-Locomotion in Lunar Environment. NASA TN D-2176, 1964.
2. Hewes, Donald E.; and Spady, Amos A.: Moon Operations Here on Earth. Reprinted from Astronautics and Aerospace Engineering. NASA RP-207, 1964.
3. Spady, Amos A., Jr.; and Krasnow, William D.: Exploratory Study of Man's Self-Locomotion Capabilities With a Space Suit in Lunar Gravity. NASA TN D-2641, 1966.
4. Hewes, Donald E.; Spady, Amos A., Jr.; and Harris, Randall L.: Comparative Measurements of Man's Walking and Running Gaits in Earth and Simulated Lunar Gravity. NASA TN D-3363, 1966.
5. Letko, William; Spady, Amos A., Jr.; and Hewes, Donald E.: The Problems of Man's Adaptation to the Lunar Environment. Langley paper presented by Amos A. Spady, Jr. at a Workshop Sponsored by National Academy of Sciences, National Research Council Committee on Hearing, Bioacoustics, and Biomechanics, at the Ames Research Center, Moffett Field, Calif., Jan. 25-27, 1966.
6. Kuehnegger, W.; Roth, H. P.; and Thiede, F. C.: A Study of Man's Physical Capabilities on the Moon. Vol. III - Work Physiology Research Program. Doc. No. NSL 65-153 (NASA CR-66119), Northrop Space Labs.
7. Hewes, Donald E.: Analysis of Self-Locomotive Performance of Lunar Explorers Based on Experimental Reduced-Gravity Studies. NASA TN D-3934, 1967.

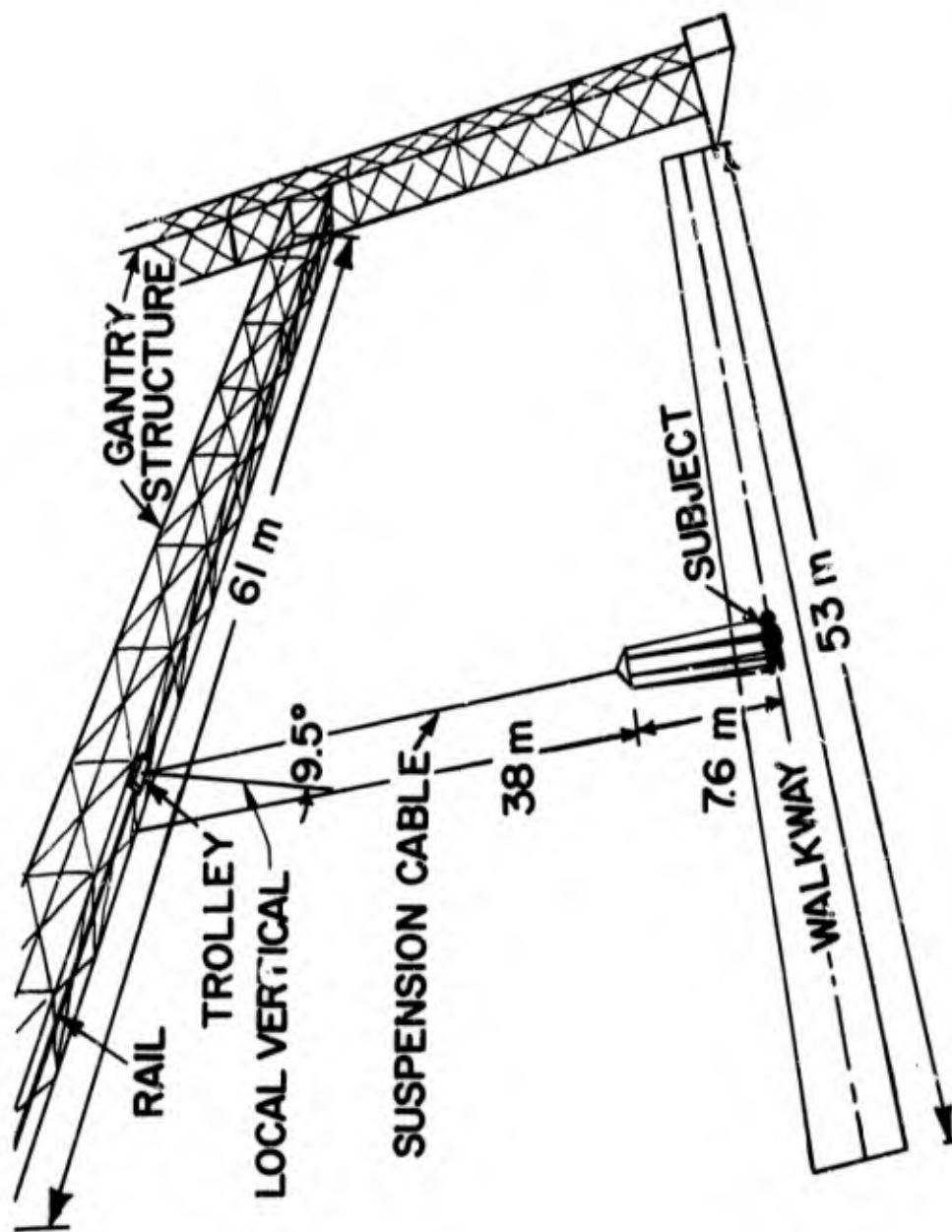

Fig. 1 Sketch of the Lunar Walking Simulator employing the inclined-plane technique developed at the Langley Research Center



Fig. 2 Details of sling support system for test subject in the Lunar Walking Simulator

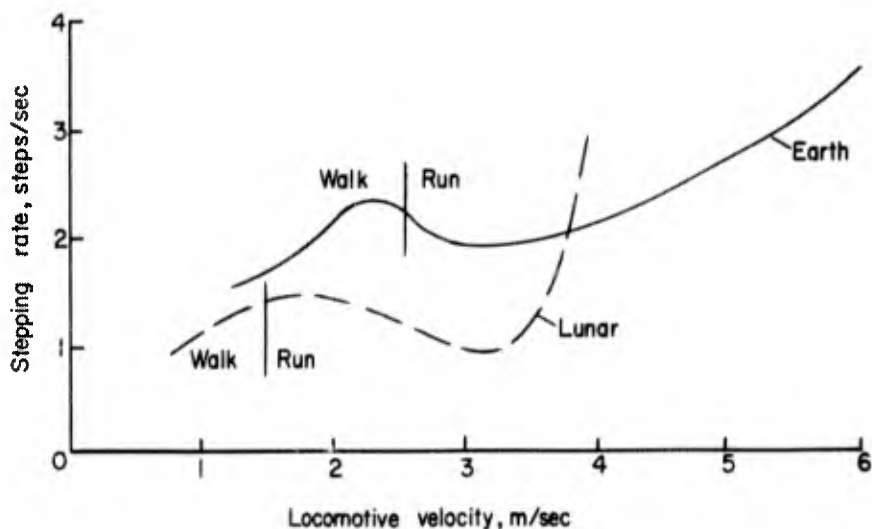

Fig. 3 Variation of stepping rate with locomotive velocity for earth and simulated lunar gravity as derived from data presented in reference 1. Subjects were wearing conventional flying coveralls and walking on a smooth firm surface.

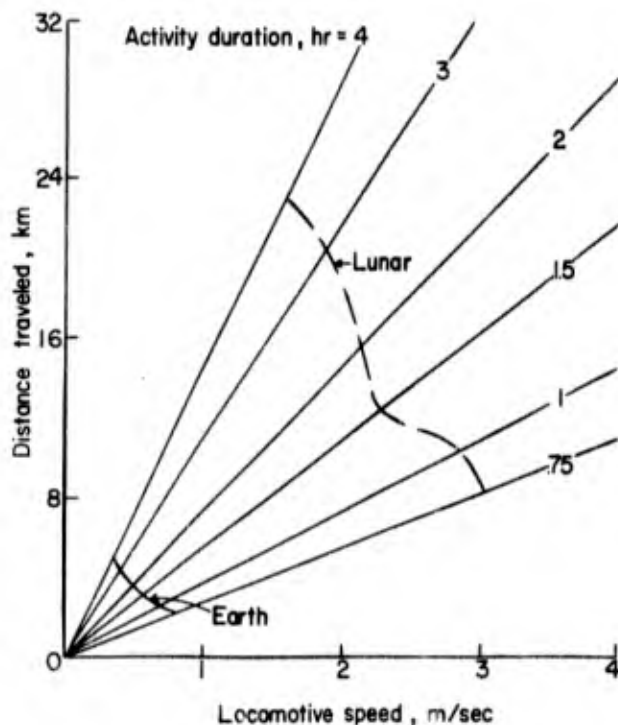

Fig. 4 Calculated range capability or distance traveled for different locomotive speeds for test subjects wearing pressurized Mark IV suit and 32.7-kilogram (72-pound) backpack in earth and simulated lunar gravity obtained from reference 7

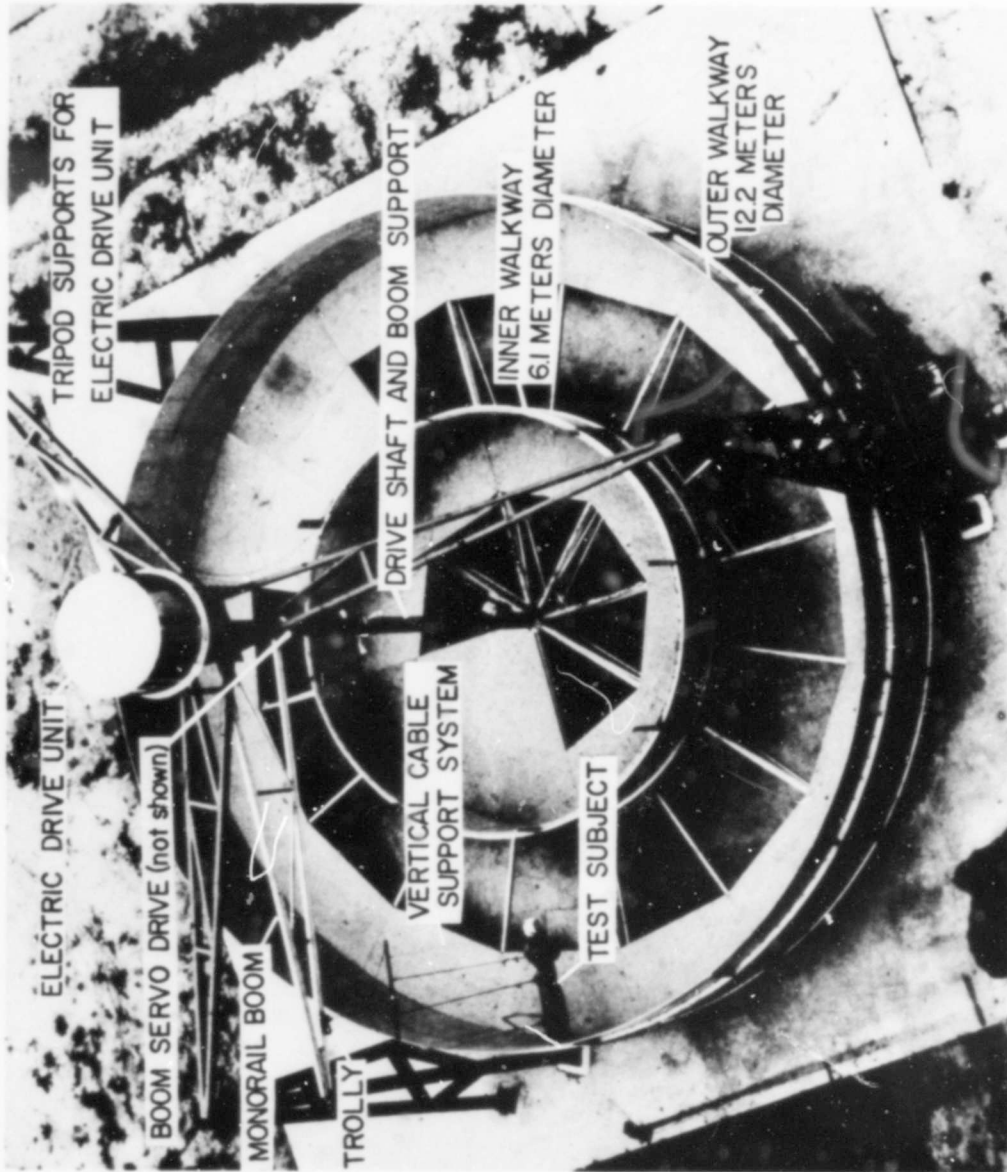

Fig. 5 Photograph of the Rotating Space Station simulator developed at the Langley Research Center

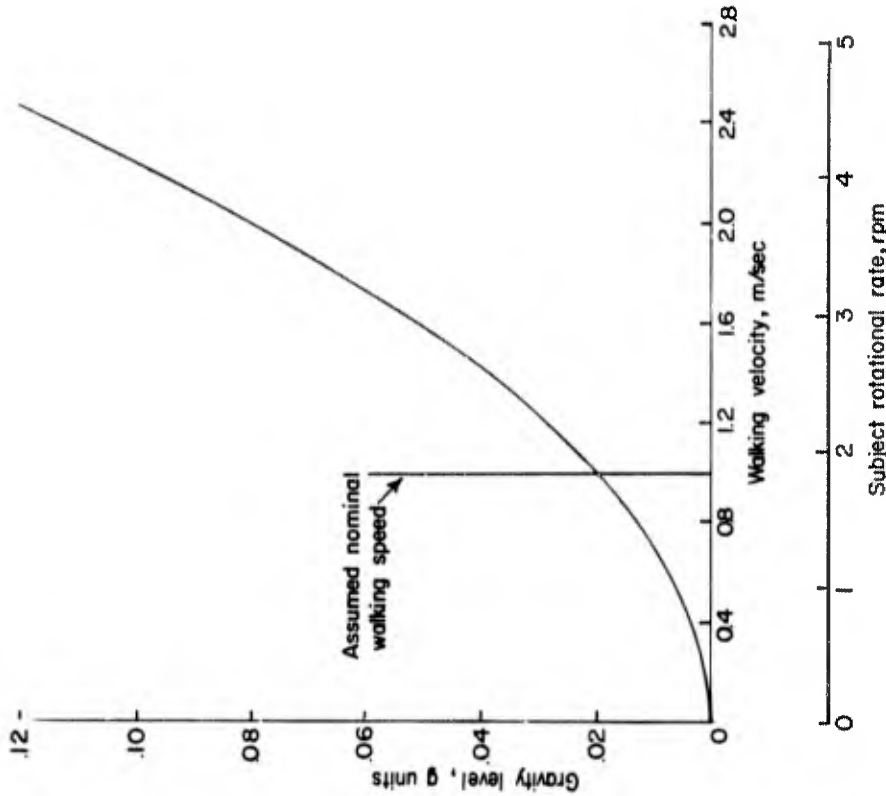

Fig. 7 Variation of gravity level with walking speed of subject on walkway with diameter of 12.2 meters and no rotation

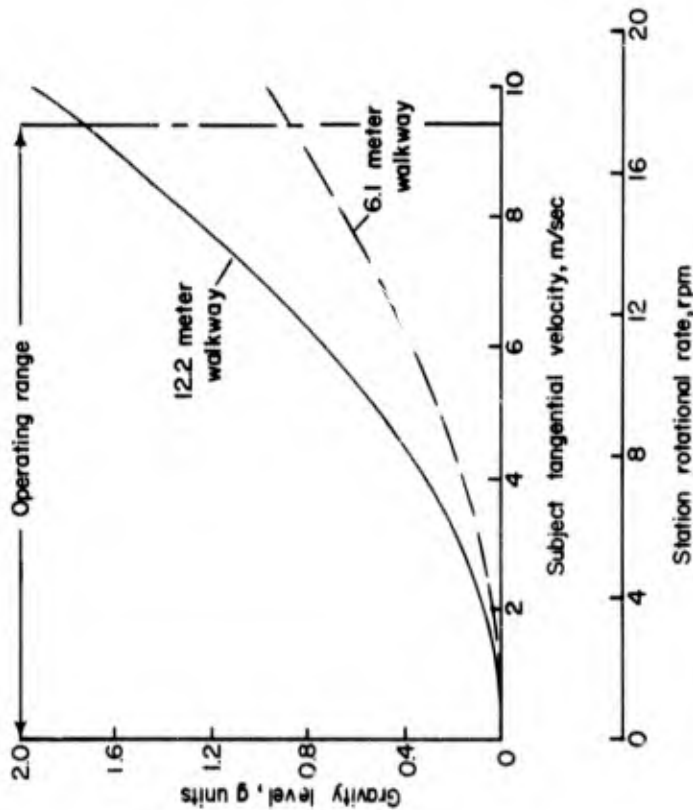

Fig. 6 Variation of simulated gravity level with station rotational rate and tangential velocity at center of gravity of subject standing on the two walkways with diameter of 12.2 and 6.1 meters

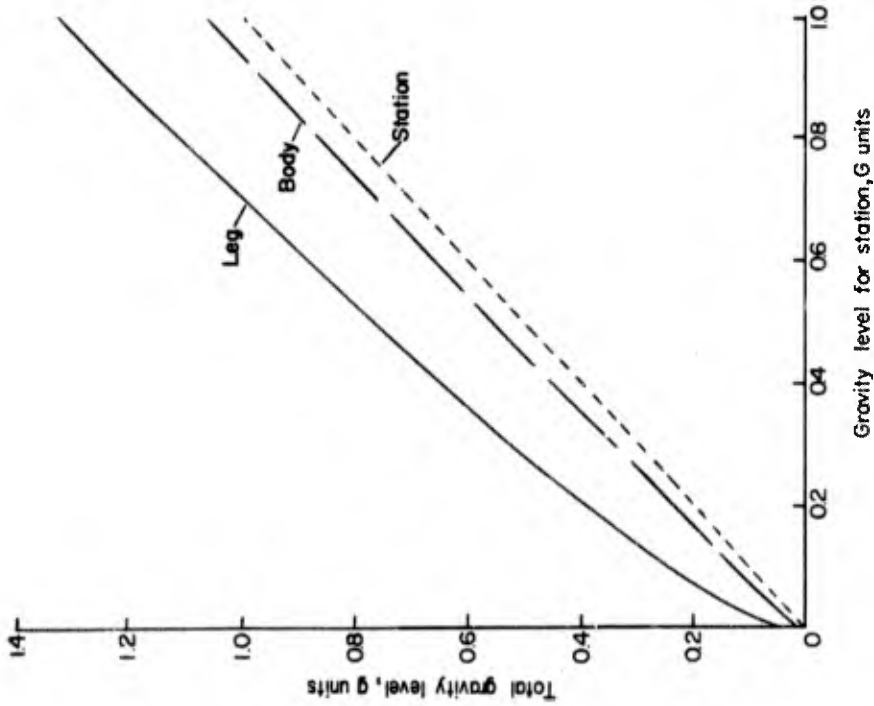

Fig. 8 Calculated variation of the gravity level due to swinging motion of leg as experienced by the leg and the body as a whole during a walk at 1 meter per second on the walkway with a diameter of 12.2 meters

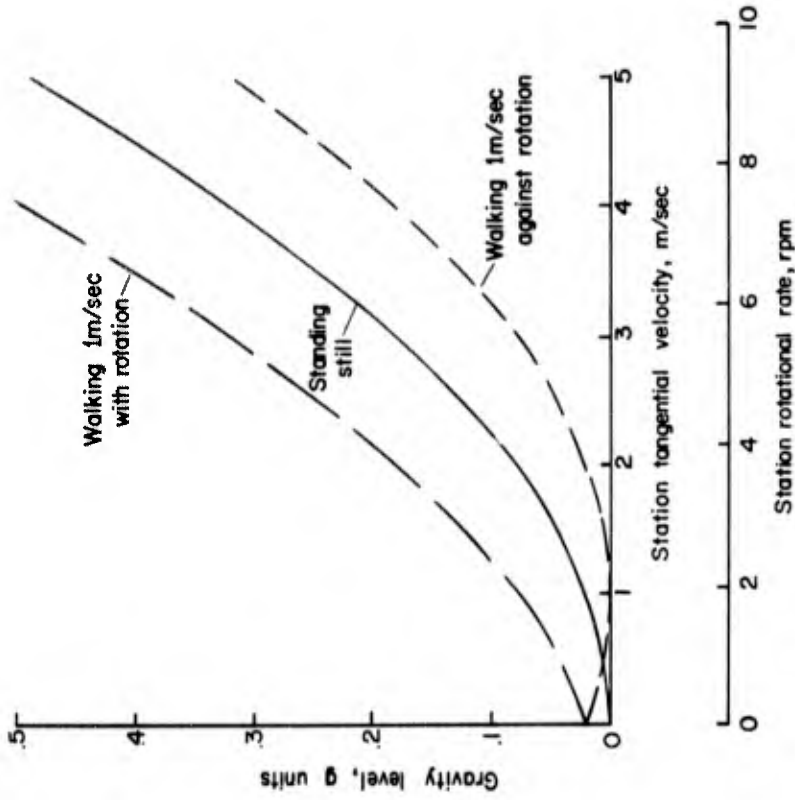

Fig. 9 Effect of walking at 1 meter per second on the gravity level produced by rotation of the 12.2 meter walkway

AREAS OF COINCIDENCE IN AEROSPACE

AND

SUBMARINE MEDICAL RESEARCH

CHARLES F. GELL, M.D., D.Sc Med.

Scientific Director

Submarine Medical Research Laboratory
Naval Submarine Medical Center
Box 600, U.S. Naval Submarine Base New London
Groton, Connecticut 06340

SUMMARY

The following discussion identifies the bio-medical problems existing in aerospace and submarine-diving activities that have similarity in their physical aspects and the psychophysiological response of man thereto. These problems are identified in three, time/altitude and time/ocean depth relationships. The physical stressors in both aerospace and ocean environments are related to: lack of breathing oxygen, toxic gases, bends, cold, explosive decompression, atmospheric ionization, circadian rhythm alterations, disorientation, vertigo and respiratory response to rare gases. Psychological problems of similarity are stated as Human Factors Engineering, Selection of Personnel, Reaction to Confinement, Isolation, Training and Simulation Methods.

NOTATION

C	Carbon
CO ₂	Carbon dioxide
H	Hydrogen
H ₂ O	Water
HeO ₂	Helium oxygen mixture
N ₂	Nitrogen
O ₂	Oxygen
cu. ft.	Cubic feet
psi	Pounds per square inch

AREAS OF COINCIDENCE IN AEROSPACE
AND
SUBMARINE MEDICAL RESEARCH

CHARLES F. GELL, M.D., D.Sc Med.
Scientific Director
U.S. Submarine Medical Research Laboratory
Groton, Connecticut, U.S.A.

The problem areas which are coincident in Aerospace Medicine and Submarine-Diving Medicine are immediately apparent upon the close scrutiny of the individual environments. The casual observer, in considering the watery environment of the seas and the apparently vacant media of aerospace, can reasonably speculate on their vast natural differences. In actuality, however, the two media have great similarities in certain of their physical aspects and the physiological responses of man thereto when human habitation is considered.

Man's habitat is on the boundary between gas and solid or, in the case of this discussion, between a gaseous and liquid media. The dissimilarity between looking up into space and down into the sea seems to be quite positive, but the biophysical similarities become quite apparent to the serious student of physical and biological function.

Initially we find that man's flying difficulties arise in traversing the gaseous media from the region of greatest gas pressure to that of little or no gas pressure. In so doing he encounters several physical changes that render the media humanly uninhabitable without mechanical support. Man's difficulties in the liquid media arise from a reversal of the aforementioned transition with the vehicle now going from a region of sea level pressure to one of several sea level pressure equivalents. The end result in both cases is identical in a biological sense, mainly the lack of the necessary elements for the support of human life.

In ascent to the space environment man has a slight "breathing spell" between the surface atmospheric pressure and that of the space equivalent. Above this he enters an environment that is totally unsupporting to the maintenance of animal life. There is insufficient oxygen to breathe, no moderation of heat to warm, and no sustenance whatsoever for man. Descending into the sea presents the same problems. If the space ship and submarine are envisioned as two manned, hermetically sealed capsules in a sterile environment, a comparison is made. If the egress of man from

the capsule into the surrounding environment clothed in a protective suit is envisioned, then the comparison is complete.

In classifying the physical-physiological stressors in both aerospace medicine and submarine-diving medicine we can assume the three following analagous spatial relationships:

1. First, flying at an altitude up to 35,000 feet and diving to a depth not exceeding 100 feet as seen in Slide (1) introduces certain identical stressor mechanisms identified as:

- a. Lack of breathing oxygen
- b. Expansion of free gases in body cavities on ascent in aircraft and in ascent from a dive.
- c. Potential aeroembolism in rapid aerial ascent and divers bends in rapid ascent from the ocean depths.
- d. Loss of body heat: ascent to 35,000 feet in unheated aircraft and descent to ocean depths exposes the aviator and diver to extremes of cold.
- e. Vertigo and disorientation are potential stressful symptoms in both environments.

2. Second, flight to altitudes that represent the maximum ceiling for aircraft (about 100,000 feet) compared to diving to maximum depths as in an exploratory diving vehicle, Slide (2). Here man is encased in a flying or diving capsule. The similarities of physical-physiological stressors are again:

- a. Lack of breathing oxygen
- b. Metabolically generated toxic gases
- c. Loss of body heat
- d. Possible structural failure of vehicle resulting in explosive decompression in the aircraft or divers squeeze in the submarine.
- e. Escape problems:

(1) Anoxia and cold in the parachute escape from aircraft.

(2) Anoxia, cold, and potential bends in escape from diving vehicle.

3. The third environmental analogy is one in which a manned space craft in space is compared to a submarine cruising in the ocean depths. Slide (3).

In both of these situations we have a hermetically sealed capsule which is partially recycling its internal gaseous and liquid components to maintain metabolically the encapsulated human operators.

In the case of the submarine this is a more complete procedure and the systems are presently in a more advanced state of development than those in use in space craft. However, the development of total atmospheric recycling is a must for long-term space flight and, since greatly extended underwater cruising of a year or more is not a requirement in submarines, it is considered that space ship environmental control systems will acquire greater sophistication than those in submarines.

Comparatively the space ship of the Apollo type and the submarine of extended underwater capability present the following common problem areas:

1. Breathing O₂ supplies

Oxygen to maintain the crew in the submarine is continuously produced by water electrolysis. A large oxygen supply is also carried in the compressed oxygen banks to provide for extended or emergency use. These can be replenished by shipboard generation and serve as a reservoir. The present system in the space vehicle is one of straight O₂ provisioning from compressed oxygen tanks with some oxygen regeneration as a result of CO₂ scrubbing.

Eventually a complete recycling system for O₂ regeneration must be developed for long-term space flights. This will possibly end up as a black box for direct photosynthetic regeneration of O₂ from H₂O and CO₂. A small O₂ regeneration device would be of great value to future submarines and underwater habitations. It has been suggested that the C and H residuals could be combined into alcohol or carbohydrate. Gin or candy, the choice is yours!

2. Toxic gases

The average man exhales CO₂ at the rate of 110 cu. ft. per hour. It is apparent that in a space ship or a submarine, a toxic concentration of CO₂ would be generated in a short time unless a CO₂ absorptive system is maintained. In the submarine the CO₂ is removed by scrubbers of complicated design, while in the space craft simpler chemical CO₂ devices are used.

The submarine has an air purifying system that removes 300 potential contaminants by filtration, electrostatic precipitation, or catalytic burning. These systems are more sophisticated than those in today's space vehicle as dictated by operational requirement, but the space ship constructed for long-term space flight will eventually need similar equipment.

Toxicological problems arising from the outgassing of paints and materials as well as the excretions of man are common to both submarines and space ships. Additionally, there is a relatively high CO concentration in submarines due to the insistence of man in maintaining his primary vice of smoking.

3. Aeroembolism/divers bends

It is possible for the syndrome of aeroembolism to be a complicating factor in a space ship if structural failure results in a reduction of internal pressure. Of course, the failure of the vehicle resulting in explosive decompression would be catastrophic. In a like manner free escape from an incapacitated submarine on the bottom could result in a similar syndrome of divers bends if the exposure at depth and rate of ascent were contributory.

4. Medical problems associated with O₂ toxicity are remote, but possible, in today's space ships and submarines. Submarines operate with an internal gas pressure equivalent to sea level and with normal partial pressures of O₂ and N₂. The present day space vehicle utilizes a 5 psi pure O₂ pressure. This pressure has not provoked the oxygen poisoning syndrome in the extended flight of 14 days, but no one knows whether this will hold true for flights of 60 days or more. Saturation diving in relation to fixed submarine habitations presents the problem of O₂ poisoning if the O₂ partial pressure is not reduced to a proportionate sea level O₂ concentration. In breathing compressed air at 150 to 200 foot depth the N₂ should be replaced to prevent N₂ narcosis and toxicity. This is accomplished through the use of a helium-oxygen mixture at a pressure that is equivalent to that of the sea water surrounding the man, but with the percentage of oxygen in the mixture reduced to a sea-level density equivalence.

5. Atmospheric ionization and aerosol increase may be a problem in both space craft and submarines. Atmospheres in confined spaces subject to high energy sources can become relatively highly ionized. The physiological effects of different concentrations of ions that may be preponderantly of one polarity in comparison to natural atmospheres should be more carefully evaluated in the psychophysiological aspects of closed environments. In addition, a confined atmosphere may result in a gradually increasing collection of aerosols. The long-term physiological effects of high aerosol concentrations are also of significance.

6. Diurnal cycles of physiological functions and their psychological manifestations under confinement in both environments are a matter of joint concern. The work-rest-sleep cycle has become more of a problem with the advent of long-term detached confinements as in space flights and nuclear submarines.

Man's physiological functions and psychological performance vary according to a 24-hour rhythm based on an endogenous time clock adjusted to the terrestrial environment. When this time clock is out of phase with the external environment, a state of asynchrony in physiological function is possible with a decrease in human performance. This is demonstrated in occasional night workers and passengers on jet flights. Further investigation is warranted.

7. Similar derangements of special sense response can occur in both the space vehicle and in the submarine environment. Special visual and labyrinthine problems exist in space flight and in submarine work when occupants engage in extravehicular activity. Man outside of his space vehicle may have visual problems due to lack of visual cues, intense sunlight or darkness, and viewing through vast distances with no atmospheric interference. In extravehicular activity outside of a submarine the man also can have visual difficulties due to murkiness, specific particulate matter in the water resulting in color change, and stratified movement of water layers due to the action of currents.

Disorientation can result from exposure to the weightless field of space and, similarly, the neutralizing buoyancy of water can confuse the diver as to his spatial orientation.

Voice changes occur both in space and in underwater work when a HeO₂ mixture is used. The HeO₂ mixture is used in both aerospace and submarine work as a replacement gas for N₂, primarily to prevent N₂ toxicity in diving and to reduce the potential of aeroembolism in aerospace flight. The characteristic changes in tone and pitch can render speech unintelligible in both cases and further study in the communication problems thus related are a mutual concern.

Vertigo. Aviator's vertigo in response to motion, disorientation, and labyrinthine involvement in expanding internal gases is a well known syndrome. The symptoms related above are not uncommon in diving to considerable depth and in ascent therefrom.

8. Psychological problems common to aerospace flight and to submarine-diving environments fall into analagous categories. These are:

- a. Human factors engineering
- b. Selection
- c. Personnel assessment
- d. Reaction to confinement and isolation studies
- e. Training methods
- f. Simulation methods

All of the above functions are imperative requirements both in the preparation for long-term space flight and in extended submergence in submarine atmospheres. These methods and functions are very similar and a great deal can be gained from either discipline by comparative evaluations.

9. Safety, escape and rescue:

The medical functions involved in these procedures are related to the physiological soundness of the protective equipment used, and the rules and regulations related to the necessary procedures.

In both space flight and deep submergence the safety of the man will necessarily be directly associated with procedures related to biological functions. In both cases the operator will have to don protective gear and be ejected into a hostile environment with specific gear to sustain him until rescue arrives. The physiological evaluation of this equipment will be important in all cases to provide the maximum possible protection under the circumstances.

DISCUSSION

In consideration of aerospace flight and submarine-diving operations it is apparent that a significant relationship exists between the physical stressors to man and his physiological-psychological reactions in response thereto in both media. It then appears that research and development efforts of both environmental areas should be a matter of close scrutiny, one with the other, to maximize the potential support which can be mutually gained from interchange of information relative to their individual research and development efforts.

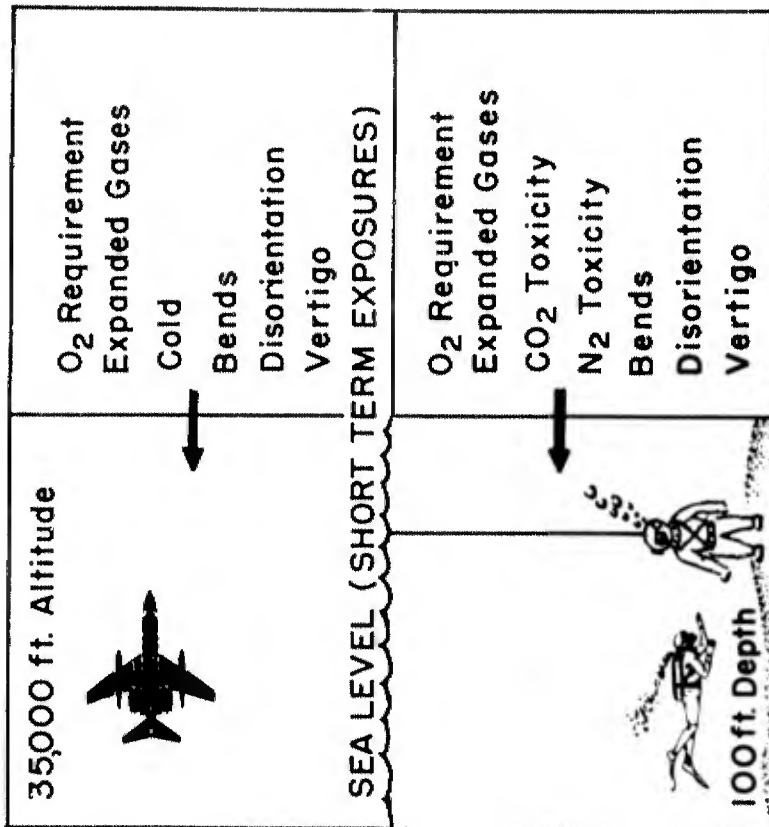

Fig. 1

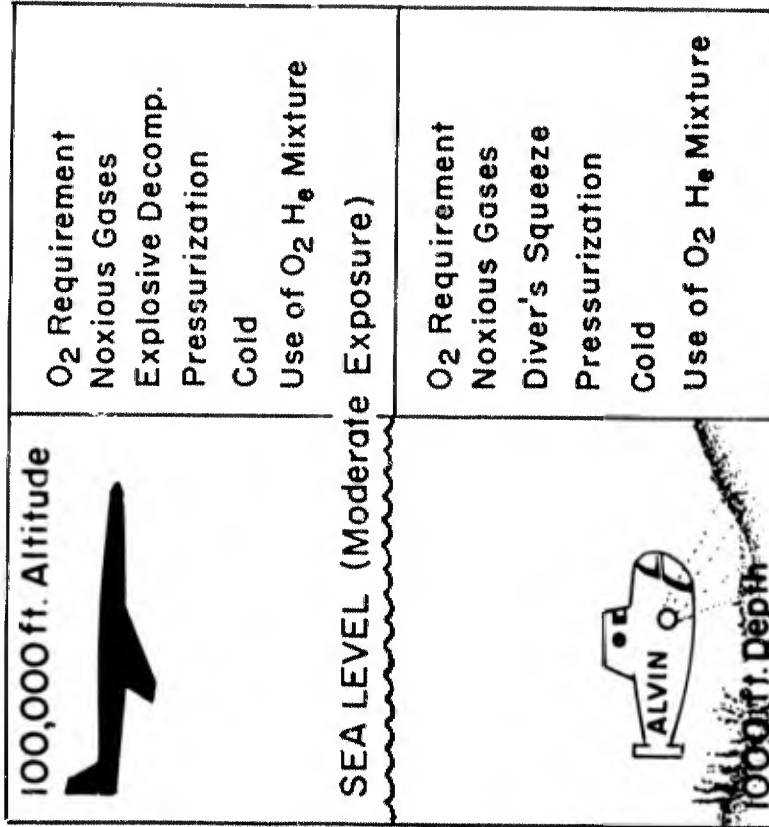

Fig. 2



<p>SPACE</p>  <p>SEA LEVEL (Long Time Exposures)</p>	<p>Atmospheric Environ- ment Controls Explosive Decomp. Toxicological Problems Diurnal Cycles Selection & Training React. to Confinement Safety, Escape & Rescue</p>
<p>Skipjack</p>  <p>OCEAN DEPTHS</p>	<p>Ditto</p>

Fig. 3

ETUDE DE L' ACTION BIOLOGIQUE DES RAYONS COSMIQUES -
AU MOYEN DE BALLONS SONDES

par

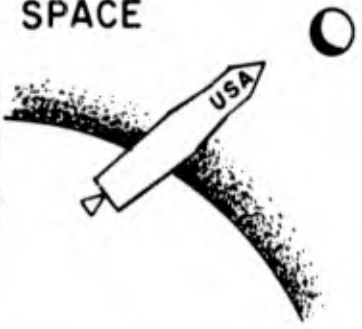
Médecin Commandant A.Pfister, Spécialiste de Recherches,
Médecin Capitaine G.Deltour, Assistant de Recherches,
H.Atlan, R.Kaiser et L.Miro

C.E.R.M.A.
5 bis, Avenue de la Porte de Sèvres
Paris (15^o)

RESUME

Cette communication concerne les recherches, effectuées au Centre d'Enseignement et de Recherches de Médecine Aéronautique de Paris depuis trois ans, sur les effets biologiques des ions lourds du rayonnement cosmique primaire. Les études ont été réalisées à l'aide de ballons sondes entraînant à 30.000 mètres des containers récupérables. Les expériences furent de deux types:

- les unes portaient sur des souris noires C 57. Elles ont permis d'étudier les lésions anatomopathologiques provoquées au niveau de la peau par le passage ou la désintégration des ions lourds ainsi que les modifications de l'anabolisme protéique (méthodes autoradiographiques);
- les autres, effectuées sur des préparations bactériologiques, ont mis en évidence des effets mutagènes. Des expériences à visée quantitative, permettant de déterminer les coefficients d'Efficacité Biologique Relative (E.B.R.) des particules lourdes, sont actuellement en bonne voie de réalisation. La sensibilisation des tests repose sur l'utilisation de cultures concentrées et sur un meilleur repérage des traces des particules dans les cultures.

ETUDE DE L'ACTION BIOLOGIQUE DES RAYONS COSMIQUES - AU MOYEN DE BALLONS SONDES

A. Pfister, G. Deltour, H. Atlan, R. Kaiser, et L. Miro

1. INTRODUCTION

Les vols à très haute altitude, réalisés par les avions de reconnaissance modernes et bientôt par les transports supersoniques, les voyages dans l'espace, posent toujours un problème: celui du danger radiobiologique afférent aux radiations cosmiques. Cette question a déjà été très étudiée dans de nombreux pays: les opinions ont beaucoup varié, les unes très pessimistes, les autres très optimistes. Le risque couru ne semble pas avoir entravé le développement des expériences spatiales et des vols à haute altitude. Néanmoins, il faut avouer qu'il n'est pas encore possible d'avoir une idée objective de ce danger.

On sait que le risque n'est pas négligeable au cours des éruptions chromosphériques. En dehors de ces accidents solaires, les débits de dose globaux, mesurés sous nos latitudes, ne semblent pas dangereux si l'on ne considère que les données de radiobiologie classique. Ainsi, au-dessus de la station de lancement de ballons d'Aire-sur-l'Adour, située au 46ème^o Nord Géomagnétique, le débit de dose n'atteint en moyenne que 15 à 17 millirads/24 heures à 30.000 mètres d'altitude.

Il faut remarquer cependant que ces faibles débits ne donnent qu'une mesure d'absorption d'énergie dans la matière d'un faisceau de radiations, très différentes les unes des autres suivant leur nature et leur énergie. Le risque biologique réel, qui menace les êtres vivants exposés aux radiations cosmiques, ne nous semble pas pouvoir être évalué en fonction d'une débit de dose global. Les divers composants du rayonnement ont des efficacités différentes. On connaît les E.B.R.* des protons (1) et des particules α (2 à 3). Ces derniers sont liés au coefficient de Transfert d'Énergie Linéaire (T.E.L.). c'est-à-dire au pouvoir d'ionisation tout au long des trajectoires des particules. Lorsque le T.E.L. est plus important que 5.000 paires d'ion/micron de tissu, il n'existe plus de relation qui permette d'extrapoler la valeur des E.B.R. C'est là que réside la grande inconnue des radiations cosmiques entre 20 et 30.000 mètres d'altitude. On sait qu'elles sont constituées par un fort pourcentage de protons et de particules α dont les E.B.R. sont connues, mais ils comportent aussi 1 à 3% de particules lourdes, noyaux atomiques dont la charge va de 6 à 26 (noyau du fer) et quelquefois beaucoup plus, jusqu'à 90. Ces particules sont douées d'énergies énormes atteignant plusieurs milliers de millions d'électrons-volts. Leur flux est peu important sous nos latitudes (moins de 10 particules/mètre carré stéradian/seconde à 30.000 mètres au-dessus d'Aire-sur-l'Adour). Il faut remarquer cependant que leur pouvoir d'ionisation est au maximum dans ces premières couches de l'atmosphère où elles interagissent violemment avec les noyaux atomiques qu'elles peuvent rencontrer.

* E.B.R: Coefficient d'efficacité biologique relative. Ce coefficient multiplié par une dose en rad donne en rem l'efficacité biologique d'une radiation.

Le faible flux des ions lourds, leurs énergies énormes, le peu de sensibilité des tests bactériologiques, sont des obstacles pour déterminer les E.B.R. de ces radiations. On ne peut pas reproduire leurs conditions d'apparition avec les accélérateurs de particules. Les meilleurs moyens d'étude sont réalisés par les ballons-sondes et par les vols réels.

Les travaux, effectués au Centre d'Enseignement et de Recherches de Médecine Aéronautique de Paris, comportent deux types d'expériences: les unes étudient les modifications de la peau et des phanères des souris de race C 57 black, les autres tendent à mesurer le pouvoir mutagène des ions lourds sur des bactéries. Jusqu'à présent, tous les essais biologiques effectués n'ont eu que des résultats qualitatifs: ils démontrent l'existence d'un danger radiobiologique dû aux ions lourds.

2. EXPERIENCES REALISEES SUR DES SOURIS NOIRES C 57 BLACK

Les expériences, entreprises par CHASE et SIMONS depuis 1953 aux Etats-Unis et par notre équipe depuis trois ans, montrent que les impacts d'ions lourds ont un effet lésionnel visible sur la peau des souris noires.

Cinq expériences réussies nous ont permis d'exposer des souris noires à l'altitude moyenne de 30.000 mètres pendant plusieurs heures entre les 45ème et 40ème parallèles.

2.1 Techniques

Les souris étaient disposées par groupes de 10 ou 12 dans des containers étanches à double paroi d'acier inoxydable isolés thermiquement. Une source d'oxygène régulée maintenait la pression et la composition du mélange gazeux ($P_B - 550$ mm Hg, $P_{O_2} - 100$ mm Hg); du silicagel et de la chaux sodée permettaient l'absorption de la vapeur d'eau et du gaz carbonique. Les souris étaient alimentées pendant le voyage par des carottes fraîches en quantité suffisante pour assurer leur besoin en eau et en aliments. Des plaques d'émulsion nucléaire étaient placées à l'intérieur du container pour donner des indications sur l'intensité et le type des radiations reçues par le système expérimental au cours du vol. Un thermomètre à minimum permettait de vérifier le bon fonctionnement de l'isolation thermique (température minima de 10° C pour une température extérieure de $- 56^{\circ}$ C). Un système d'horlogerie permettant la séparation du container et du ballon, un système de repérage radio et un parachute complétaient l'équipement de la manipulation.

2.2 Résultats

Les animaux supportèrent sans difficulté des séjours de 2 à 8 heures en altitude. Ils ne présentaient aucun trouble apparent au moment de leur récupération et furent mis en observation avec un lot de souris témoins de même âge et de même fratrie.

L'atteinte causée par les rayons cosmiques se marque par l'apparition de zones limitées de dépigmentation des poils: 1 à 3 zones par animal, de préférence sur les flancs, comprenant une vingtaine de poils décolorés en ligne ou en touffe (Fig. 1). Ces modifications apparaissent après 4 à 5 semaines et sont définitives.

Histologiquement, on observe, dans les zones touchées, un aspect sénescant de la peau. On ne trouve que des poils dépigmentés dont le bulbe est superficiel: il ne semble plus y avoir de régénération caractérisée normalement par des bulbes profonds. La synthèse de la mélanine est absente totalement (Fig.2).

Une étude autohistoradiographique* a été réalisée sur des lambeaux de peau contenant une région dépigmentée au milieu d'une zone normale. Les animaux avaient reçu une heure avant leur sacrifice $5\mu\text{Ci/g.}$ de DL. Phénylalanine ^3H (cet acide aminé est un précurseur de la tyrosine et de la mélanine). Ce travail a montré que l'anabolisme protéique était diminué de près de 50% dans les follicules des poils blanchis (Fig.3 et 4).

2.3 Commentaires

Certaines particules cosmiques peuvent donc avoir un effet retardé et définitif sur des fonctions cellulaires et tissulaires bien spécialisées comme la synthèse de la mélanine et des protéines ou la régénération des poils. CHASE et SIMONS ont pu prouver à l'aide d'émulsions nucléaires placées sur la peau que les traînées de blanchiment étaient bien causées par des impacts d'ions lourds ou des étoiles de désintégration.

L'atteinte lésionnelle est beaucoup plus étendue que ne le laisserait prévoir le simple cylindre d'ionisation entourant la trajectoire des particules estimé à 6 microns en moyenne par SCHAEFFER. Il existe dans les tissus organisés une action diffuse dont le mécanisme nous échappe. L'énorme pouvoir de pénétration des ions lourds peut faire présager des lésions profondes de l'organisme. Une exposition chronique à de telles radiations peut être dangereuse par l'altération définitive de certains groupes cellulaires endocrines ou nerveux. Nous avons constaté que les souris exposées étaient toutes mortes trois à quatre mois avant leurs congénères qui avaient servi de témoins. Leur croissance était retardée (2 souris pesaient moins de 20 grammes). Ces résultats mériteraient une étude particulière car nos constatations portent sur trop peu d'animaux pour pouvoir être confirmées par les lois de la statistique.

Ce type d'expérience illustre bien les raisons qui nous poussent à rechercher un moyen d'évaluation du danger apporté par les ions lourds. Bien que la dose globale à 30.000 mètres soit de 15 m rads/24 heures, il existe des lésions graves et irréversibles, localisées autour des impacts des particules lourdes. L'utilisation de tests bactériologiques appropriés permettra sans doute d'approcher cette évaluation.

3. ETUDE DES MUTATIONS BACTERIENNES INDUITES PAR LES IONS LOURDS

3.1 Etudes Qualitatives

Nous avons pu mettre en évidence l'effet mutagène des ions lourds sur les bactéries. Au début, nous utilisons une technique qui consistait à exposer dans des containers à 30.000 mètres des cultures de bactéries déficientes pour la synthèse d'un acide aminé, ensemencées en film continu sur des boîtes de Pétri contenant un milieu impropre à leur croissance. Seules les bactéries subissant une mutation reverse développaient

* Travail réalisé avec l'aide du Département de Biologie du C.E.A. (Saclay).

des colonies prototrophes. La détection des trajectoires d'ions lourds était réalisée à l'aide de plaques d'émulsions nucléaires interposées entre les boîtes de Pétri emplies. Ces émulsions étaient étudiées par les spécialistes du Département de Physique Corpusculaire du Centre de Recherches Nucléaires de Strasbourg (Professeur CUER). Il nous fut possible de constater une correspondance entre l'efflorescence de colonies mutantes et les impacts d'ions lourds ou les étoiles de désintégration.

Les résultats positifs étaient toutefois trop peu nombreux pour être exploités quantitativement. Les cultures en surface ne permettaient pas d'observer convenablement le phénomène.

3.2 Etudes à Visées Quantitatives

Nous avons essayé de sensibiliser le test en utilisant des cultures concentrées de bactéries incorporées à un peu de gélatine. Cette pâte de colibacilles contenait 10^{12} bactéries par gramme. Elle était incorporée dans de petites cavités cylindriques de 1 mm de diamètre et 1 mm de profondeur creusées dans des plaques de plexiglas. Les plaques étaient entassées, séparées les unes des autres par des émulsions nucléaires de 100μ et de 600μ (Fig. 5). Après un séjour de 8 heures à 30.000 mètres, les émulsions minces furent développées et par corrélation on put prélever les cylindres de concentré bactérien traversés par des ions lourds. Ces échantillons furent mis en culture, numérisés etensemencés sur milieu déficient. L'émulsion épaisse était destinée à l'étude approfondie des caractéristiques des particules incidentes.

Cette méthode nous a permis de progresser du point de vue technique, mais elle ne nous a pas apporté de renseignements suffisamment précis pour donner des résultats significativement valables. Alors que chez la souris on observe une action très disproportionnée à la taille du cylindre d'ionisation des trajectoires, due sans doute à un mécanisme indirect qu'il s'agit encore de définir, ici, seules les bactéries touchées par l'ionisation directe sont lésées. On peut ainsi calculer qu'environ 10^5 bactéries seront concernées pour un échantillon total de 10^9 bactéries. Ceci explique qu'une telle méthode ne pouvait que difficilement mettre en évidence des modifications génétiques dans un échantillon traversé par un ion lourd.

Ayant mis en évidence cette imperfection, nous allons nous attacher à étudier les modifications qui se produisent dans les quelques dizaines de microns qui entourent les trajectoires d'ions lourds. Nous avons adapté, dans ce but, une souche de colibacilles très radiosensible à survivre dans les émulsions nucléaires et les divers produits nécessaires au développement photographique. Nous avons l'intention de prélever, par micromanipulation, les cylindres du mélange bactéries-émulsion ayant pour axe principal les trajectoires des ions lourds. De cette manière, nous pourrions étudier:

- l'action létale des ions lourds,
- leur action mutagène,
- leur action inductrice sur la lysogénie.

Ces renseignements devraient nous permettre d'évaluer les E.B.R. des particules lourdes en fonction de leurs caractéristiques physiques.

En définitive, les travaux que nous avons effectués nous portent à croire qu'il existe un danger radio-biologique aux vols prolongés à très haute altitude mais l'appréciation de ce risque est encore loin d'être bien définie et nécessitera de nombreuses expériences dans les années à venir.

Travail réalisé au Centre d'Enseignement et de Recherches de Médecine Aéronautique à Paris (Médecin Général TABUSSE) et au Département de Physique Corpusculaire du Centre de Recherches Nucléaires de Strasbourg (Professeur CUER).



Fig.1 Souris exposée pendant 8 heures à 30.000 mètres d'altitude. Après 5 semaines, on voit nettement sur les flancs des petites touffes de poils blancs en traînées

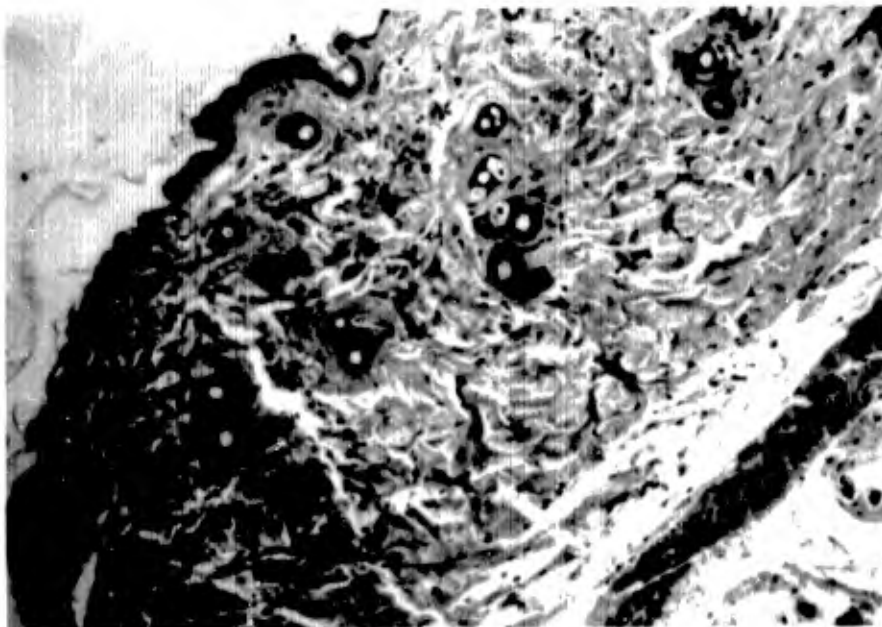

Fig.2 Coupe histologique de la peau de souris noire exposée à 30.000 mètres pendant 8 heures. Zone porteuse de poils blancs. Noter la minceur de l'épiderme, la densité du derme, l'absence de bulbes pileux profonds. Les poils ne contiennent pas de granulations de mélanine



Fig.3 Autoradiographie de bulbes pileux situés dans l'hypoderme d'une zone cutanée normale. La mélanine des poils apparaît nettement en grosses plaques noires. Les autres granulations correspondent à l'incorporation de la DL. Phénylalanine tritiée

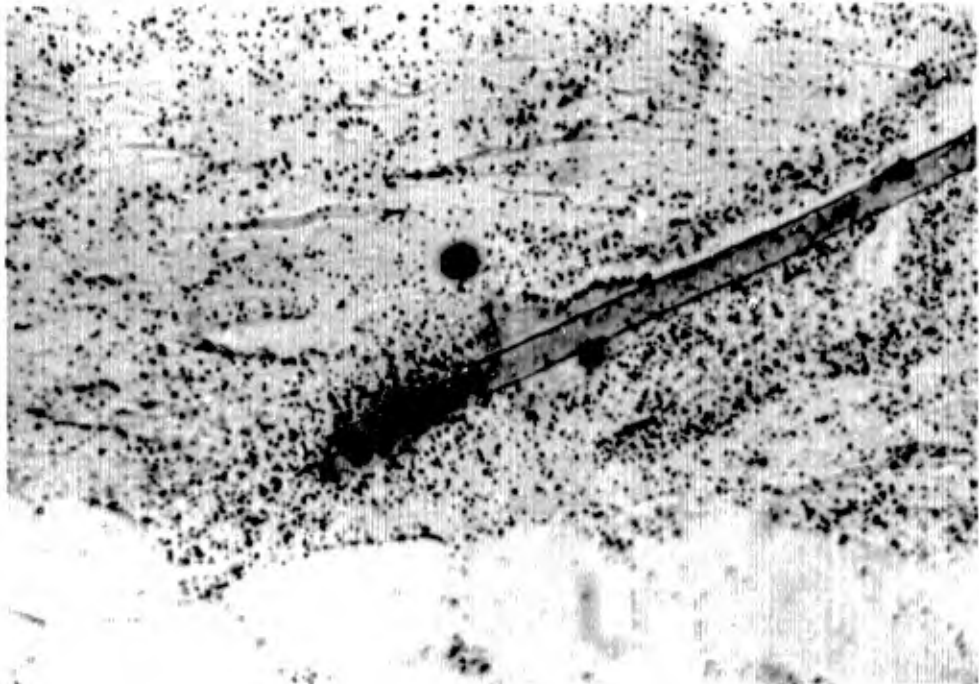

Fig.4 Autoradiographie d'une zone cutanée altérée. (Même préparation que pour la figure précédente). Existence d'un poil blanc; noter la baisse importante d'incorporation de DL. Phénylalanine tritiée

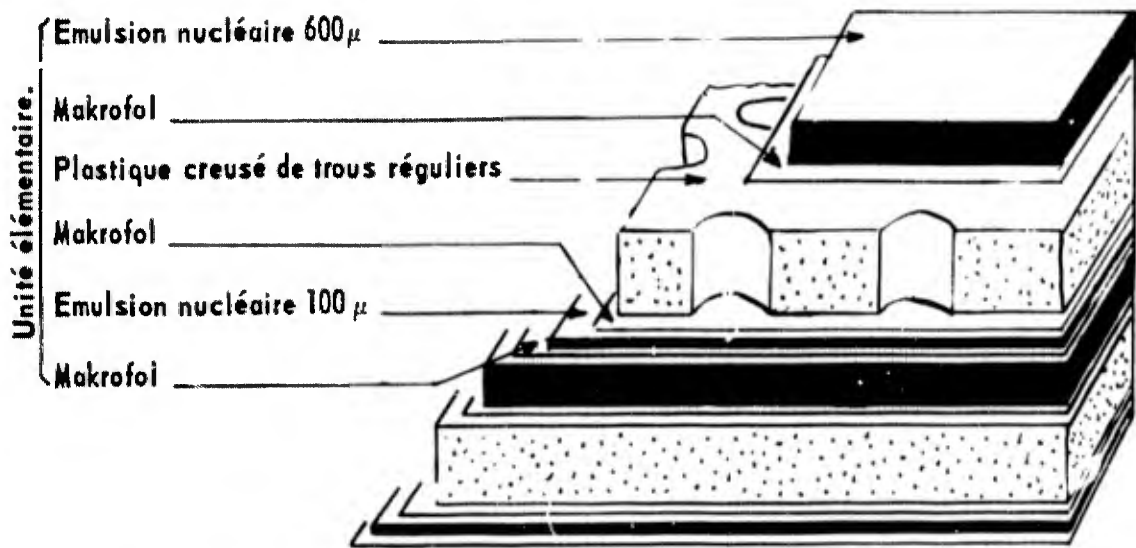

Fig.5 Aspect schématique en coupe du dispositif utilisé. Le dispositif complet comporte un empilement de vingt unités élémentaires de ce type: quatre tiges guides placées aux angles assurent la cohésion de l'ensemble

THE RADIOBIOLOGICAL HIATUS IN SPACE

by

E.R. Ballinger, Colonel, USAF, MC

Brooks Air Force Base, USA

BLANK PAGE

THE RADIOBIOLOGICAL HIATUS IN SPACE

E. R. Ballinger, Colonel

When one begins to review many years of studies* in radiobiology and observes in more recent years the effort placed upon quality measurements of physical dose, a feeling of confidence develops. It appears that so much has been learned so well that from this large accumulation of data there is little left but to apply the information to any special situation, and all will be well. And so we may look for instance at lethal doses - the $LD_{50/30}$ - and we will find values ranging from 300 rad to perhaps twice that value for most mammals, for man variously stated from 400-600 rad.

But these values are for Co^{60} , Cs^{137} , of 150-300 Kev x-rays at conventional delivery rates of 100-1,000 rad/hour or more. What about the lethality from space energy protons, 30-100 Mev at dose rates also characteristic of space, 1-10 rad/day? Limited information using Co^{60} at dose rates down to 100 rad/day suggests an $LD_{50/30}$ of several thousand rad for the mammal, but there is no information on protons or electrons at low dose rates. The Tables and Figures I would present points out this and several other areas where we are lacking in information and illustrates the extent of our difficulties in extrapolation by comparing clinical and experimental doses and energies with the doses and energies of concern in space.

Table I lists these areas of concern: radiation type and energy; dose rate; exposure frequency; dose.

Table II serves to expand upon the first area of concern by comparing clinical and research energy and types with the energies and type encountered in space.

As we examine the site of damage moving from 33 Mev to 55 Mev protons in the rhesus monkey skin and liver respectively, we find acute damage which undergoes some repair. The delayed damage at 6-9 months is probably secondary to a damaged vascular bed.

Table III based upon calculation and histopathology attempts an extrapolation to man.

Looking at the second area of concern, Table IV compares dose rates, clinical versus space and Figure 1 further illustrates the dose rate effect and the disparity of data in and below the region of several hundred rad/day in the rodent. Similarly the hematopoietic response appears dose rate dependent. The oft-quoted dose of 30-40 rad to produce a drop in lymphocytes is probably closer to several hundred rad at space dose rates.

* The animals involved in these studies were maintained in accordance with the "Guide for Laboratory Animal Facilities and Care" as published by the National Academy of Sciences - National Research Council.

Table V compares exposure frequency. Recent studies at the School of Aerospace Medicine in support of a much broader study at the Naval Radiological Defense Laboratory throw considerable doubt on any single simple mathematical description of recovery between two exposures. Periods of dramatic radioresistance in the pig and sheep have been identified in paired dose studies while in the rhesus monkey, a period of hypersensitivity between the 20th and 30th day postexposure occurs. In clinical radiotherapy some effort is made to base the periodicity of a series of exposures either upon tumor sensitivity, or upon the tolerance of the patient; however in reality the frequency of exposures is more often determined by the convenience of the physician or the workload and working hours of the radiotherapy unit. Thus animal data at the moment may be the best we have to proceed upon.

And finally Table VI considers the dose itself, the last of the four areas of concern. The importance here is in terms of whole versus partial body exposures. For superficial tissue damage the threshold for erythema for instance varies with area irradiated as it appears does deep tissue damage with the volume of tissue irradiated.

From these considerations certain generalities may be made but not quantitated.

1. The incidence of radiation-induced lethality in space will be remote as compared with the incidence of tissue damage to the skin, eyes, and other superficially located organs. The low energies and low dose rates of space support this assumption.
2. Following a single sizable exposure a second mission should not be undertaken with the assumption of a recovery expressed commonly as for instance 10-20% per day of the recoverable fraction.
3. As mission durations increase, life support equipment will also increase, making a contribution to shielding. As flights become heavily shielded the radiation of concern will become predominantly gamma, bremsstrahlung, and neutrons rather than protons and electrons. Our understanding and our ability to extrapolate these radiation effects to man may then be facilitated.
4. For prolonged flights where possible a rigorous adherence to exposure criteria will be carried out during the early stages. In the latter stages if the accumulated dose permits, a less constrained criteria may be followed. One can envision a radiation panel with four dials (1) Accumulated dose; (2) Dose rate; (3) Rate of change of dose rate; (4) Extrapolated accumulated dose to termination of flight. This latter factor may have several alternatives according to associated risk.
5. Finally the more serious problems may be psychological due to prolonged isolation and confinement on say for instance a three-year flight to a distant planet. That man will be aboard if only to increase the probability of success seems assured in our present state of technology.

That continuous nuclear or other exotic propulsion systems may considerably shorten any given mission is beyond doubt; however, this may only serve to make even longer trips a real consideration. That hypothermic, hypoxic, and metabolic reduction techniques may be used in view of the associated reduction in weight of life support systems seems not improbable. Noted here in conclusion is that these same metabolic modification techniques have been observed as means of modifying the expression of radiation damage in a favorable direction.

TABLE I

Radiation Differences

1. Radiation Type and Energy
2. Dose Rate
3. Exposure Frequency
4. Dose

TABLE II

Radiation Type and Energy

<i>Clinical/Research</i>	<i>Space</i>
Co ⁶⁰ γ > 1 mev	BREMSSTRAHLUNG γ < 1 mev
β 2-40 mev	β 0.5 - 5 mev
P 150-600 mev	P < 100 mev

TABLE III

Proton Penetration in Primate and Man

<i>Organ</i>	<i>Primate* Depth in Tissue (cms)</i>	<i>Proton Mev to Center</i>	<i>Approx. Man Depth in Tissue (cms)</i>	<i>Proton Mev to Center</i>
Liver	3.5	64	12.0	130
Kidney	2.7	55	8.0	100
Marrow (Sternal)	1.1	34	2.0	48
Marrow (Pelvic)	2.1	49	6.0	86
Mid-Brain	3.0	60	8.0	100
Optic Lens	0.6	24	0.9	30
Heart	3.3	62	8.0	100
GI Tract	2.5	52	12.0	130
Testis	1.0	32	1.5	40
Ovary	4.0	69	10.0	120

* Measured from cross-sectional atlas of anatomy of 3.2 kg MACACA MULATTA: Center of organ to nearest skin surface.

TABLE IV

Dose Rate

<i>Clinical Research</i>	<i>Space</i>
50-500 rad min.	< 0.1 rad/min.

TABLE V

Exposure Frequency

<i>Clinical Research</i>	<i>Space</i>
1-10 Exposures 1-10 Days Between	1-10 Exposures Over Duration of Mission

TABLE VI

Dose

<i>Clinical Research</i>	<i>Space</i>
1-1000 rad Partial Body	1-1000 rad Whole Body

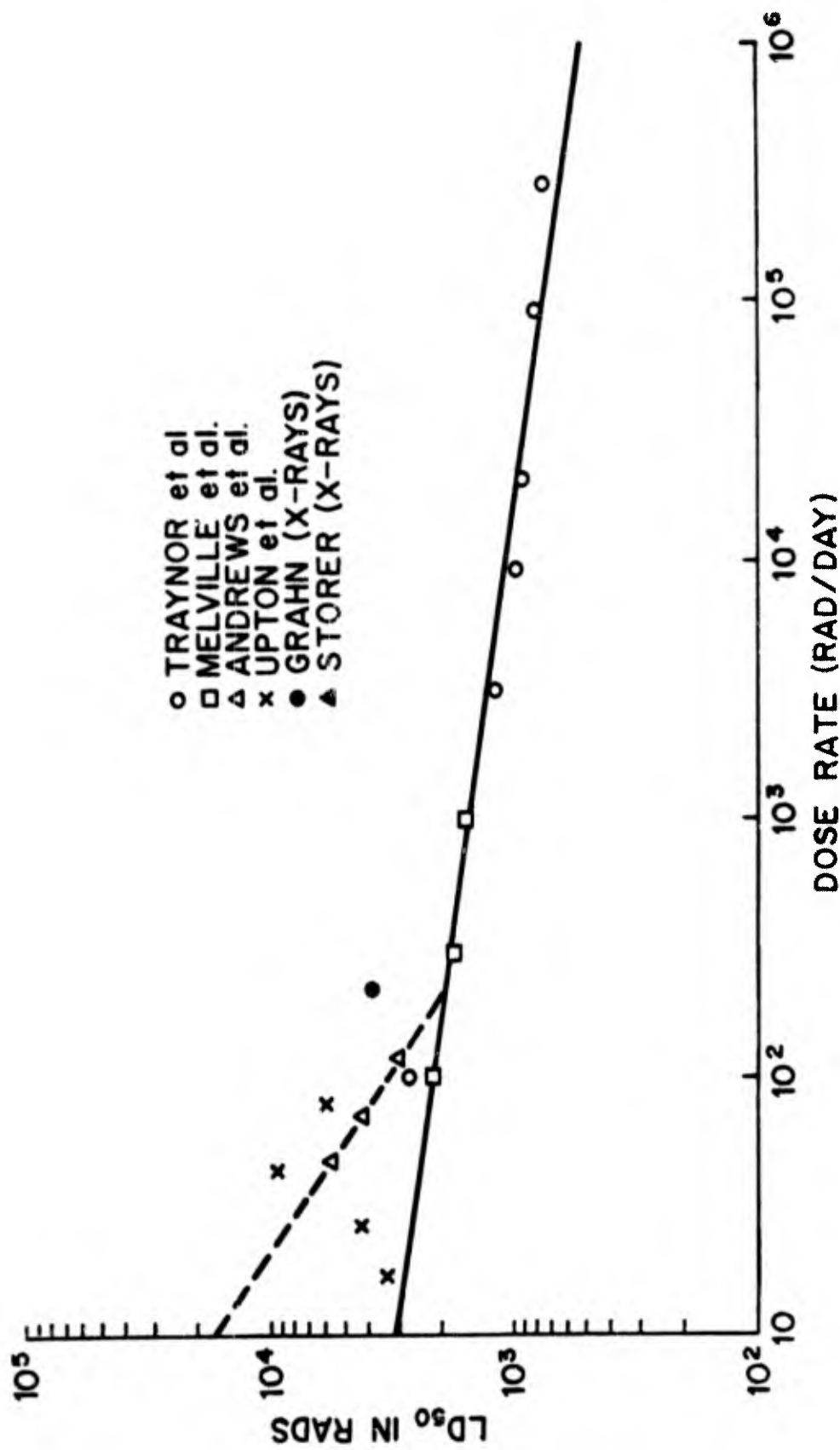

Fig. 1 Comparative data - LD₅₀ versus dose rate

SLEEP REQUIREMENTS DURING MANNED SPACE FLIGHT

by

Louis F. Johnson, Jr

Colonel USAF, Medical Corps
Deputy Director of Bioastronautics
Aerospace Medical Division, AFSC
Los Angeles Air Force Station
Los Angeles, California 90045

SLEEP REQUIREMENTS DURING MANNED SPACE FLIGHT

Louis F. Johnson, Jr

Man has a ubiquitous need for sleep no matter what his habitat. This is amply demonstrated by the fact that he spends about one-third of his adult life in sleep (1). When man has tried to do without sleep, his performance has degenerated. It is not known whether sleep is a 'pay-back' period of time when man gets rid of 'toxins' that have built up during his waking period or whether it is a period of 'regeneration' when his brain and body are being reprogrammed for another period of wakefulness; perhaps it is a combination of the two. Whatever its nature, sleep is a necessary state into which man must periodically lapse and during which he is largely not responsive to his environment.

Without sleep, man degenerates psychologically and behaviorally. Studies dealing with the need for sleep have dealt mainly with the deprivation of sleep. Such commanding figures as Napoleon and Frederick the Great considered sleep a waste of time (2) and decided to do without it. They each succeeded in going for 48 hours without sleep before being involuntarily overcome by it. Over the years, there have been many sleep deprivation studies. Total deprivation studies (1) show that there are increasingly evident manifestations of abnormalities with increasing deprivation: from subjective fatigue to lack of efficiency in mental and physical functioning to behavioral changes such as irritability, perceptual distortion and hallucinations.

As the study of sleep became more sophisticated and sleep was described as existing in several stages (3) and not being a mere unitary state of 'sleep' versus 'wakefulness', more sophisticated sleep deprivation studies were done. Dement (4) reported on the results of 1-REM sleep deprivation and Agnew et al. (5) reported on the results of stage 4 sleep deprivation. These differential deprivation studies showed that, despite normal duration of sleep, insufficient depth of sleep will also lead to deterioration of performance. Sleep research is currently a very active and growing field. In the light of the current state of the art, we must consider the quality as well as the quantity of sleep.

In planning bioastronautics support for manned space flight, we have given much thought to the human needs of the astronauts in order to keep them in good physical and mental condition. We have given them proper partial pressures of oxygen to support life, adequate barometric pressure within their space capsules, and elaborate pressure suits; we have developed special foods and diets and methods for providing water; and we have given thought to removing toxic contaminants from the atmosphere and man's own waste products of carbon dioxide and human excreta. In this planning, have we given adequate consideration to the astronauts' need for sleep?

Accepting as a planning factor that sleep is a necessity, quantitatively and qualitatively, we can ask ourselves three questions: 1. How much sleep is necessary? 2. What quality or depth of sleep is necessary? and 3. What periodicity of the wakefulness/sleep cycle is satisfactory for good performance?

The easiest way to answer all of these questions is to say, "remain on the earth pattern of 16 hours of wakefulness and 8 hours of sleep." The astronauts will certainly be in constant or periodic communications contact with earth and earth will remain on a normal 24-hour cycle with Greenwich Mean Time as the reference. However, duties of the astronauts, exigencies and emergencies will probably preclude a completely normal earth wakefulness/sleep cycle. In that case, what answers can we give to the questions posed?

The total amount of sleep should be one-third of the total time, or 8 hours out of each 24 (1, 6).

The quality or depth of sleep should remain normal. Agnew et al. (5) have shown that two 4 hour sleep periods do not give the same amount of sleep at various depths as one period of 8 hour sleep. Thus differential sleep deprivation could occur over a period of time.

As to periodicity of sleep, Hartman (6) at the USAF School of Aerospace Medicine has studied three wakefulness/rest schedules as they affected performance. These were 4 hours work/4 hours rest, 4 hours work/2 hours rest and 16 hours work/8 hours rest, cycled in each 24 hour period. Performance of psychomotor tests was the measure of adequacy of well-being; no objective depth of sleep measurements were done. His subjects were able to perform (for 12 days) at approximately the same level on all these schedules until an added stress was added. Then, the subjects following the 16 hours work/8 hours rest cycle showed the smallest psychomotor decrement.

CONCLUSIONS:

1. We may say that astronauts on prolonged space flights should have 8 hours of continuous sleep at their normal depth of sleep out of each 24 hours, if possible.

2. If conclusion 1. is not operationally practicable, a different wakefulness/rest ratio must be used, for example, 12 hours work/6 hours rest plus another 2 hour rest period in each 24 hour period.

3. Further experimental work on the quality or depth of sleep as affected by differential cycling of the 24 hour time period is necessary.

REFERENCES

1. Kleitman, N.; "Sleep and Wakefulness", 2nd Edition, (Chicago University Press, 1963).
2. Strughold, H.; "The Physiological Clock in Aeronautics and Astronautics"; Annals of the New York Academy of Science; 1965; 134, 413-422.
3. W.Dement and N.Kleitman; "Cyclic Variations in EEG During Sleep and Their Relation to Eye Movements, Body Motility and Dreaming"; Electroencephalography and Clinical Neurophysiology, 1957, 9, 763-690.
4. Dement, W.; "The Effect of Dream Deprivation"; Science, 1960, 131, 1705-1707.
5. Agnew, H.W., W.B.Webb and R.L.Williams; "Comparison of Stage Four and 1-REM Sleep Deprivation"; Perceptual and Motor Skills, 1967, 24, 851-858.
6. Hartman, B.O. and G.K.Cantrell; "The Effect of Demanding Work Schedules Compounded by Sleep Deprivation"; U.S.A.F. School of Aerospace Technical Report 67-99, October 1967.

SYSTEMATIC EVALUATION OF THERMAL ASPECTS OF
AIR CREW PROTECTIVE SYSTEMS

by

RALPH F. GOLDMAN

Military Ergonomics Laboratory

United States Army Research Institute of Environmental Medicine

Natick, Massachusetts, U.S.A.

Summary:

The systematic study of a proposed uniform begins with an analysis of the insulation (clo) and evaporative transfer (i_m) properties of the basic fabrics, individually and subsequently as the composite layers in the uniform system. These initial fabric investigations are carried out both on a dry, and a wetted, heated flat plate. The uniform items are then evaluated on an anthropomorphic heated and "sweating" manikin so that the insulation and evaporative properties of the uniform, as worn, can be evaluated. A computer model for human thermal balance is then programmed with these values and the tolerance range for wear of such a uniform is calculated as a function of wearer workload, ambient temperature, vapor pressure, wind velocity and solar load. The results are plotted on a psychrometric chart. Finally an environmental chamber evaluation of the ensemble may be carried out with volunteer subjects, at one of the critical points suggested by the computer prediction, to confirm the predicted stress level and investigate other human factors aspects. Our experience has been that the stress level found in such an evaluation is almost always in agreement with that predicted from the clo and i_m indices.

Introduction:

Until very recently, making clothing was strictly an art and even today only clothing for certain sports, for the military and for astronauts is designed primarily to requirements other than fashion. While air conditioning and central heating allow man's ordinary clothing to serve fashion rather than comfort, the space or modern battlefield environment places demands on clothing which are often in conflict with respect to a man's survival and comfort. For example, high durability and protection from high velocity particles and radiation must be provided simultaneously with low weight and bulk; permeability to water vapor may have to be provided at the same time that impermeability to liquid water and to other vapors is desired. Ultimately military, and perhaps civilian clothing, will probably consist of a completely encapsulating garment with an intrinsic conditioned air source similar to that for suits now worn by astronauts. At present such a general solution, while feasible, is prohibitively expensive. This report presents the scientific approach being used by the U.S. Army Research Institute of Environmental Medicine, Natick, Massachusetts, to evaluate the protection provided against heat and cold injury as well as to consider thermal problems in support of a number of clothing programs of other government laboratories developing current military clothing and carrying out research toward this goal.

The "clo" unit:

Some years ago physiologists working in the field of clothing and the associated heat transfer from a man, developed a technique to determine how much heat would pass through a garment by thermal radiation and convection from the skin (1). The difference between a man's skin temperature and the ambient temperature was taken as a gradient across which, to avoid a change in body temperature, he had to eliminate the difference between his metabolic heat production and the heat he could lose by evaporation of sweat from his skin or of water from his lungs. This non-evaporative component was assumed to go through the clothing by normal radiation and convection transfer. They then defined the insulation of a clothing system, plus the overlying still air layer, in terms of a "clo" unit and derived a system of units such that the dry heat transfer, i.e. convection plus radiation heat transfer, per unit of gradient ($^{\circ}\text{C}$) from skin to ambient temperature would be $5\frac{1}{2}$ calories per meter square of surface per hour, per clo; that is:

$$H_{\text{Dry}} = \frac{5.55 \text{ kcal m}^2 \text{ hr}}{\text{clo}} \text{ per } ^{\circ}\text{C} \quad \text{Equation 1}$$

This is a basic form of physical equation (e.g. Ohm's law $I = E/R$) where the heat flow equals the driving force, in this case a temperature gradient, divided by the resistance, expressed here in "clo". This basic approach for radiation-convection heat loss has been used in the design of arctic clothing, sleeping bags and other cold weather items. We are reasonably happy with making quantitative assessments of how good a sleeping bag is, or how good a given uniform is for a resting man in cold weather using this "clo" unit, since radiation and convection are major avenues of heat loss in the cold. However, for a working man in the cold, evaporation of

sweat becomes an increasingly important avenue of heat loss as the level of work increases. Further, the "clo" value tells us little in the heat, since the driving gradient for radiation and convection heat loss decreases with increasing ambient temperature. In fact, heat is gained by these avenues whenever ambient temperature is greater than skin temperature.

Predicting evaporative transfer:

A similar form of equation can be used to predict evaporative heat transfer:

$$H_{\text{Evap.}} = \frac{5.55 S (p_s - p_a)}{\text{clo}} \quad \text{Equation 2}$$

Eq. (2) is a form of the psychrometric (i.e. slung) wet bulb thermometer equation, where the "clo" value is the insulation of the air layer around the thermometer. The gradient for evaporative transfer is the difference between the vapor pressure of the surface (p_s) and the ambient vapor pressure (p_a). If we use the slope of the wet bulb lines on a psychrometric chart, (S) which is about 2° Centigrade per millimeter of mercury vapor pressure, we can convert this gradient to an equivalent temperature gradient. We can then calculate heat transfer using this gradient and thus determine the evaporative heat loss from a square meter of thermometer surface with a given water vapor pressure; for example, at 35°C, the skin temperature of a man in a sweating situation, there would be a vapor pressure of 42 mm of mercury at the skin and the gradient will thus be 42 mm minus the environmental ambient vapor pressure.

The permeability index (i_m):

The late Dr. Alan Woodcock of our laboratory proposed that the evaporative heat transfer for a nude man or any clothing system could be expressed as the ratio of the actual evaporative heat loss, as hindered by the clothing, to that of a wet bulb with equivalent "clo" insulation. He suggested expanding Eq. (2) to include this "permeability index", i_m , so that:

$$H_{\text{Evap}} = \frac{5.55 i_m S (p_s - p_a)}{\text{clo}} \quad \text{Equation 3}$$

Usual range of i_m :

This ratio of evaporative losses (i_m) could range from 0 for a system with no evaporative transfer to 1 for a system which had no more impedance to evaporative heat transfer than the usual wet bulb thermometer which, of course, is a slung wet bulb or, alternatively, a wet bulb in a wind of 7 mph or greater; in other words where even the still air barrier is greatly reduced. Since, of course, we don't sling the soldier, we very rarely get up to the point where this ratio is 1.0 for a man. For a slung wet bulb, convection and evaporation terms both become large enough that any radiant

regain of heat can be ignored; for man radiation cannot be ignored and thus " i_m " tends to be limited in still air to about 0.5 rather than 1.0; for the unslung state the radiation regain from the surrounding surfaces to the wet bulb thermometer appears as a reduction in the efficiency of the evaporative transfer.

Determination of "clo" value:

Figure 1A presents a diagram of the flat plate apparatus used in measurement of the "clo" insulation value. The apparatus consists of a test section (A), surrounded on all four sides by a guard section (B) with another guard section (C) beneath the entire upper plate (A + B). All three sections are instrumented with plate temperature sensors, heating elements and thermostats. The sample to be tested (D) is placed on the surface of the plate and the entire assembly is placed in a constant temperature cabinet. In operation, power to the guard sections is controlled so that their surface temperature is identical to that of the test section. Thus there is no gradient for heat loss from the bottom or edges of the test section (A). After equilibrium is established, the power required by the test section to maintain a constant surface temperature, in a constant ambient temperature provided by the chamber, is exactly equal to the heat lost through the insulation being tested. The required power is measured and can be expressed as kilocalories per unit test section surface area per degree of gradient from plate surface to ambient air temperature. This can be converted to the corresponding "clo" insulating value for the sample plus the adhering air layer, using Eq. (1). Air motion in the test chamber is maintained at a low, constant velocity and while the insulation value of the air layer alone can be measured (bare plate) and subtracted from the total clo determined, this is seldom necessary since some still air layer must always be present, and the relationship between the insulation of the air layer and the air velocity is known.

Determination of " i_m " value:

If we place a thin cotton "skin" on the plate surface and arrange to maintain a water level just at the surface of some small holes drilled in sections A + B, then the skin wicks out enough water to maintain a constant saturated vapor pressure at the plate surface. By maintaining a constant ambient vapor pressure in the measuring chamber and measuring power requirements just as for the dry plate, we can determine the permeability index value (i_m) for a given sample plus its adhering air layer by means of Eq. (3). Figure 1B shows the "sweating" flat plate, and its slow drip, constant feed, water supply in the constant temperature and humidity chamber with its control and recorder panel.

Role of the sweating flat plate:

The flat plate determinations of clo and i_m are primarily of use in selection of the fabrics to be used in a clothing system. The effects on heat transfers of different weaves, perforations, different finishes or treatments, the effects and best arrangement of multiple layers, etc. all

can be established using the sweating flat plate (3). As an adjunct to the flat plate, we have tried heated dry and "sweating" cylinders to mimic the cylindrical shape of the body. These have been useful in studying wind penetration through clothing, and the effects of spacer materials, but there are factors of drape, fit, and shape which are difficult to simulate even on a cylinder. Also, a complete uniform is made up of a number of different components, protecting various parts of the body, so that evaluation of a clothing system requires a more sophisticated model than a simple cylinder. (4)

The copper man:

The solution has been the development of an anthropometric "sweating", heated copper manikin. Figure 2A shows the manikin, with his cotton skin, dressed in a standard combat tropical uniform worn with a recently-adopted water repellent, water vapor permeable, raincoat. Figure 2B shows the man, dressed in a constant volume, open cell foam, wet suit developed by the Navy for the Sealab, Man-in-the-Sea program. The suit has provisions for flushing the foam with different gas mixtures, e.g. helium-oxygen, or CO₂. This copper man has 19 skin temperature thermocouples as well as heaters for each body section which, while allowing some adjustment of the heat supplied to the various segments, are all operated by a single thermostat. The control console, which meters voltage, wattage, total elapsed and also thermostat power-on time is shown beside the man, with the recorder for the 19 skin temperatures shown in the cabinet on the far right. We can measure the heat provided to maintain a constant skin temperature and we control the ambient temperature and vapor pressure of the test chamber; we measure skin and air temperature and vapor pressure. We can thus get the evaporative heat loss and the radiant and convective heat loss caused by any given gradient of temperature and vapor pressure with any clothing system worn. We have a sectional manikin with separate circuits to the torso, head, arms, legs and hands and feet so that for a given uniform system, in addition to the overall i_m and i_{cl} , we can determine what the insulation is in critical areas or, for example, isolate the thermal effects of putting on a helmet to just the head section, which improves our precision. In addition to these complete manikins, we have extra feet and hand sections for studying handwear and footwear; in addition we have a 12-section foot "calorimeter" and a 22-section hand "calorimeter" which we use to detect any areas within a boot or a glove that might have insufficient insulation in spite of an overall high value. We have recently been using proportional controllers for the manikins, with shorter times to reach equilibrium and greater precision of our results, and have developed standard operating procedures for these devices.

The role of the copper man:

This technique has been in use for the last five years. We have explored these insulation and evaporative transfer indices, "clo" and "i_m", and using these with what we know about human physiology, have predicted the tolerance times for a given task for men in the chambers and for men in the field. In other words, we work out the general equation that heat

stored by the body must be the difference between the heat a man produces at work and that which he loses by evaporation and by radiation and/or convection from his skin and through his clothing system.

Representative values of clo and i_m :

Table I presents clo and i_m values for a number of uniforms and clothing systems evaluated on the sweating copper man. Note that the still air layer alone, i.e. the insulation clo value for the nude manikin, is about 0.8 clo. This would drop toward 0.2 clo as air motion increased toward 40 meters per second. The 4.3 clo for the current standard cold-dry "arctic" uniform shown as Fig. 3, represents about the maximum practical value. While it is obvious that this uniform is excessively bulky and heavy, unfortunately an inactive soldier has only about two hours of tolerance at -40° because the insulation provided the finger tips and toes is much less than the 4.3 clo average value for the uniform. Note also that the i_m value for most uniforms is about 0.5, except where impermeable plastics or coatings or treatments that specifically reduce the permeability have been incorporated. The last column, i_m/clo , can be used, as suggested in Eq. (3), to rank these ensembles in terms of their relative stress when worn by a working man in the heat. As shown later, this ranking is quite valid except where the garments differ significantly in such factors as relative air permeability or are cut to allow extensive flapping.

Implications of clo and i_m :

Since the average soldier has 1.8 square meters of surface area, if we estimate his skin temperature for a given combination of environment and work, we can calculate his total non-evaporative heat transfer when wearing one of the uniforms included in the table for any given ambient dry bulb temperature ($^{\circ}C$) as:

$$H_{Dry} = 10(T_s - T_a) / clo \quad \text{kcal-man-hour} \quad \text{Equation 4}$$

We can similarly calculate the maximum evaporative heat transfer allowed through his clothing for any given ambient vapor pressure (mm Hg) as:

$$H_{Evap} = 20(42 - P_a) i_m / clo \quad \text{kcal-man-hour} \quad \text{Equation 5}$$

where we have assumed a $35^{\circ}C$ skin temperature for the sweating man. If we know his heat production, which can be expressed as kcal per man per hour, then, after making appropriate allowances for respiratory heat loss and any solar heat load gain, we can calculate whether the man can eliminate all the heat he is producing or whether some of it will be stored in his body. Indeed, using the specific heat of human tissue ($0.83 \text{ kcal/kg}/^{\circ}C$), we can calculate that the body temperature of a 70 kilogram soldier will increase by one degree centigrade for each 58 kcal that must be stored (i.e. 0.83×70). This approach allows us to predict tolerance time in the heat. We can also predict the lower limit of temperature for comfort in the cold as that temperature where: a) the respiratory heat loss plus b) that evaporative heat loss associated

simply with diffusion of water through the skin of a non-sweating man plus c) the heat lost by radiation and convection (i.e. "clo" losses) exactly equals the man's heat production. A similar approach has been developed to predict heat loss from the extremities as a function of the clo insulation, the circulatory heat input, the ambient temperature and wind velocity, and the mass to surface area ratio of the particular extremity expressed as its physical time constant. Thus, cold tolerance can be expressed as a condition of no loss of body heat, or more importantly as the time until loss of manual dexterity (5th finger temperature $\approx 15.5^{\circ}\text{C}$) or risk of freezing cold injury (finger temperature $\approx 0^{\circ}\text{C}$).

Validation of the approach:

A computer program has been devised which incorporates many of the significant physiological, physical and environmental factors involved in human heat transfer. If the appropriate values for clothing, environment and metabolic heat production are supplied, the model will predict the body temperature response of an individual under the chosen conditions. However, we are still exploring and expanding this model and frequently elect to check our predicted responses by actual environmental chamber exposures of men. We have developed two standard protocols, one involving a two-hour rest, then a fifty-minute walk followed by a final one-hour rest; the other requires two fifty-minute walks, separated by a ten-minute break, followed by a one-hour rest and final fifty-minute walk. These standard protocols, showing the measurements taken, are presented in Table II. Figure 4A shows the tropical environmental test chamber, with eight subjects during a period at rest. The men are seated on benches placed on the two large treadmills, each of which has a four-man capacity. Each subject is wearing a different garment since, as is usually the case, a Latin square randomization of garment, day and subject was used for this study. Each subject is wearing a rectal catheter, to measure deep body temperature, and a three thermocouple, skin temperature harness. The two connecting cables from each man are led outside the chamber, across an overhead grid, to the instrumentation shown in Fig. 4B. Each subject's rectal temperature is indicated continuously on one of the eight meters at the base of the master timer. Skin temperatures are recorded sequentially, along with the rectal and also dry and wet bulb chamber temperatures, on the strip chart recorder, which has a 160-point capacity. Each point printed on the recorder is simultaneously encoded and punched on the digital punch tape system shown at the right. This punch tape is fed to a computer at the end of each day's experiment and after the initial printout of raw data is checked, subsequent data reduction and analysis is carried out. The results of three different experiments are presented in Figs. 5A, B and C. In each case the mean body heat storage of the group of eight subjects is presented as a function of exposure time in the chamber. Environmental conditions are given in the upper left-hand corner, the activity is shown across the top and the garments worn, with their copper man clo and i_m/clo values are given in the legend at the right.

Impermeable materials:

In the study presented in Fig. 5A, a commercial, vinyl raincoat was

worn either full length or cut down by 1/4, 1/2 or 3/4 of the total length. It is notable that both the clo and the i_m/clo values determined on the sweating copper man reflect this linearity. During the rest period, as predicted, there is no body heat storage, but by the end of the walk the mean heat storage values rank in the exact order predicted. However, the difference observed between the 1/4 and 1/2 length garments is smaller than one would anticipate from the physical values, and reflects a physiologic compensation that occurred. The extra sweat a man will produce as his body temperature rises can be evaporated to provide additional cooling, if sufficient unimpeded body surface area is available. The average sweat production did increase as a function of increased impermeable coverage, and in the case of the 1/2 length garment, enough of this extra sweat was able to be evaporated to compensate for the increased body area covered by an impermeable layer. The still greater average sweat production of men wearing the 3/4 and full length garments could not be evaporated in sufficient quantities to compensate. The results of this study, in addition to confirming the approach, are of use in the design of body armor and of impermeable garments fitted with permeable patches in selected areas.

Effects of different materials or treatments:

In the study presented in Fig. 5B, fire resistant uniforms made up of either one or two layers of a new "Nomex" synthetic fibre were evaluated in comparison with a standard cotton "fatigue" and a standard cotton tropical combat uniform. All sets of these four uniform types had been laundered but not starched and, as a sub-study, an additional group (8 sets) of the fatigue uniforms was laundered and then heavily starched. Results from the copper manikin studies gave a value of 0.34 i_m/clo and essentially similar values of clo for all but the two-layer Nomex uniform. The physiologic results obtained on subjects during the chamber experiment confirm these physical results. The average heat storage values for subjects wearing the four garments with i_m/clo values of 0.34 ranged between 62 and 70 kilocalories at the end of the fifty-minute walk, while the corresponding value for the two-layer Nomex garment, which had an i_m/clo of 0.31, was 87 kcal. Thus, variation in wicking and wetting characteristics associated with differences in fibres or finish which might have produced a difference between results obtained under static laboratory test conditions and those obtained in actual human chamber studies, did not; the relative results predicted from the static, copper man tests were confirmed by the chamber evaluation.

Effects of drape or venting:

The results of another study of raincoats is presented in Fig. 5C. Impermeable coated fabric raincoats, with and without a vent inserted under a flap across the shoulder area, were compared with water repellent but vapor permeable raincoats cut to the same fashion and again with or without the vent. The standard army poncho, which is an impermeable, loose cape with hood was also included in the study. The copper man values were essentially the same with respect to clo for all garments,

while the i_m/clo values showed little or no difference associated with venting and were 0.26 for the permeable coats, 0.16 for the impermeable coated fabric coats and 0.11 for the poncho. However, the results of the physiologic evaluation showed a significant advantage for the vent in the impermeable coated fabric raincoat, no advantage for the vent in the permeable coat and the average heat storage of men wearing the poncho was nearly as low as that of men wearing the vented impermeable garment. Thus the ability offered by an impermeable garment with a vent, or by a billowing impermeable garment like the poncho, to exchange the air under the impermeable garment was of significant advantage to subjects walking in such garments. On the other hand, a vent in an already permeable garment seems to offer little or no meaningful additional air exchange. Thus, with respect to factors of fit and drape or cut which provide ventilation features, the static physical test values require careful interpretation. Additional studies involving flapping the garments during the copper manikin measurements have been carried out which are encouraging, but the technique requires additional refinement.

Conclusions:

Assessment of the insulation (clo) value and evaporative impedance (i_m/clo) value of a clothing system can provide an accurate estimate of the relative advantages of one garment or fabric over another with respect to the thermal protection and/or strain associated with wearing the clothing. There are effects of cut, drape and fit which must receive special consideration. The techniques presented are a valuable tool in clothing design and such evaluations are desirable in studies of the man-clothing-job-environment-system for ordinary clothing as well as for such advanced concepts as clothing systems with intrinsic environmental conditioning sources.

BIBLIOGRAPHY

1. Gagge, A.P., A. C. Burton and H. C. Bazett. A practical system of units for the description of heat exchange of man with his environment. Science 94: 428, 1941.
2. Woodcock, A. H. Moisture transfer in textile systems. Textile Research J. 32: 628, 1962.
3. Fonseca, G. F. Moisture transfer through perforated impermeable foam insulations. Textile Research J. In press.
4. Fonseca, G. F. and J. R. Breckenridge. Wind penetration through fabric systems. Textile Research J. 35: 95, 1965.

<u>Uniform</u>	clo	i _m	i _m /clo
None	0.78	.59	.75
Coveralls, Lightweight, Cotton	1.29	.50	.39
Jacket and Trousers, "Fatigues", Man's	1.33	.50	.37
Old Utility (8.5 oz)	1.56	.48	.31
New Utility (8.2 oz)	1.40	.48	.34
Combat Tropical	1.43	.48	.34
Standard Cold-Wet	2.56	.45	.18
Standard Cold-Dry	4.30	.48	.11
Single Layer Nomex	1.31	.45	.34
Double " "	1.55	.48	.31
Fiber 6 Coverall	1.37	.48	.35
Nylon Cotton (Nycro 50/50) Coverall	1.32	.48	.36
Water Repellent Poplin Coverall	1.27	.47	.37
Nylon Twill Uncoated Coverall	1.35	.48	.36
" " Coated with Urethane	1.27	.38	.30
" " " Butyl	1.23	.23	.19
1/4 Length Plastic Raincoat over Coat & Trousers - Man's	1.45	.40	.28
1/2 " " " " " "	1.48	.36	.24
3/4 " " " " " "	1.62	.32	.20
Full " " " " " "	1.70	.28	.16
Standard Poncho over Coat & Trousers - Man's	1.83	.20	.11

Table I. Clo and i_m values of representative uniforms

TABLE II

Standard Protocols for Clothing Studies

Schedule: Protocol I		Schedule: Protocol II			
Cumul- ative time	Approx. hour	Procedure	Approx. hour		
0	0900	Enter tropic wind tunnel maintained at "appropriate" condition. Rest, sitting for 115 minutes, without pack. Continuous rectal and skin temp recording throughout test period. Water ad lib. Pulse rates at 60 and 115 minutes.	0	0900	Enter tropic wind tunnel maintained "appropriate" condition. Walk for 50 minutes at 3.5 mph. Continuous rectal and skin temp recording throughout test period. Water ad lib. Pulse rates at 25 and 50 minutes.
115	1055	Weigh clothed, with helmet liner and pack; weigh and refill canteens.	50	0950	Rest, sitting for 10 minutes. Pulse rates at 10 minutes.
120	1100	Subjects walk for 50 minutes at 3.5 mph. Pulse rates at 25 and 50 minutes.	60	1000	Walk for 50 minutes at 3.5 mph. Pulse rates at 25 and 50 minutes.
170	1150	Rest, sitting, for 60 minutes. Pulse rates at 30 and 60 minutes.	110	1050	Weigh clothed, with helmet liner and pack; weigh and refill canteens.
			120	1100	Rest, sitting for 60 minutes without pack. Pulse rates at 30 and 60 minutes.
			180	1200	Walk for 50 minutes with pack at 3.5 mph. Pulse rates at 25 and 50 minutes.
			230	1250	Leave tropic wind tunnel. Weigh clothed, with helmet liner and pack. Strip and dry thoroughly. Weigh nude. Weigh canteens. Tabulate all water intake and output and calculate 2-hour evaporative water loss at rest, total evaporative water loss and total sweat production.

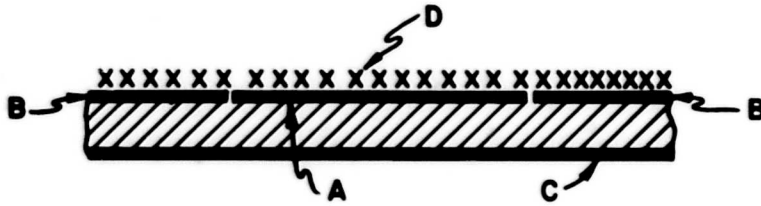

A. Diagrammatic representation of a heated flat plate

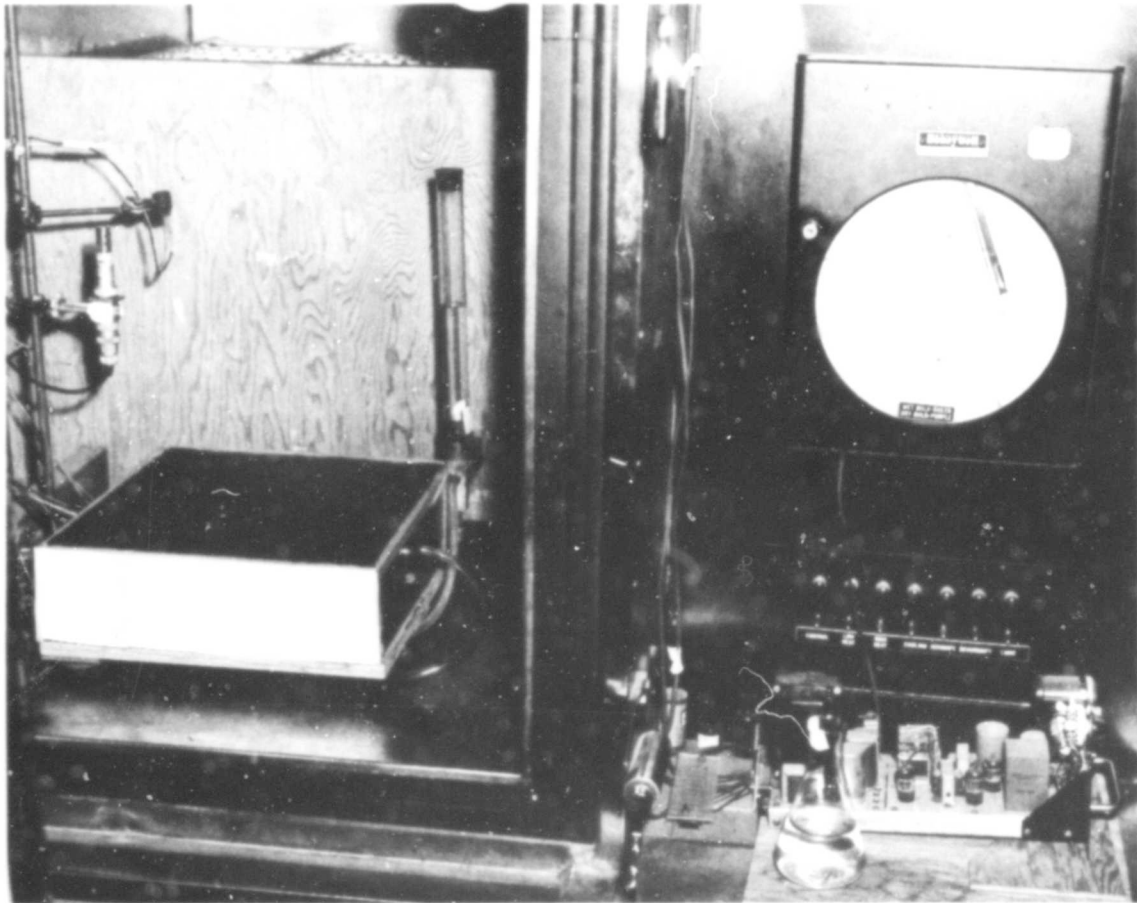

B. The "sweating" flat plate in the environmental cabinet

Figure 1



A. The sweating copper manikin

Figure 2



B. The copper manikin and its controlling and recording consoles

Figure 2 concluded



Fig.3 A 4.3 clo uniform, the current standard US Army dry-cold, arctic ensemble



A. Volunteer subjects wearing a variety of raincoats, during a rest period inside the tropic environment test chamber



B. The physiologic data acquisition system for the environmental chamber

Figure 4

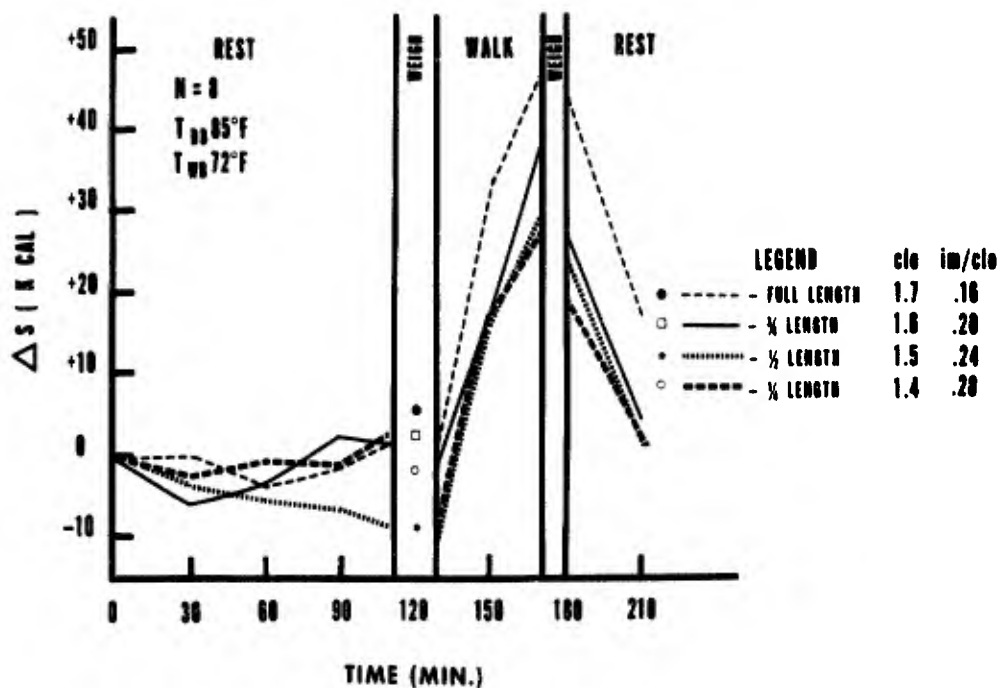

A. Different length impermeable coats

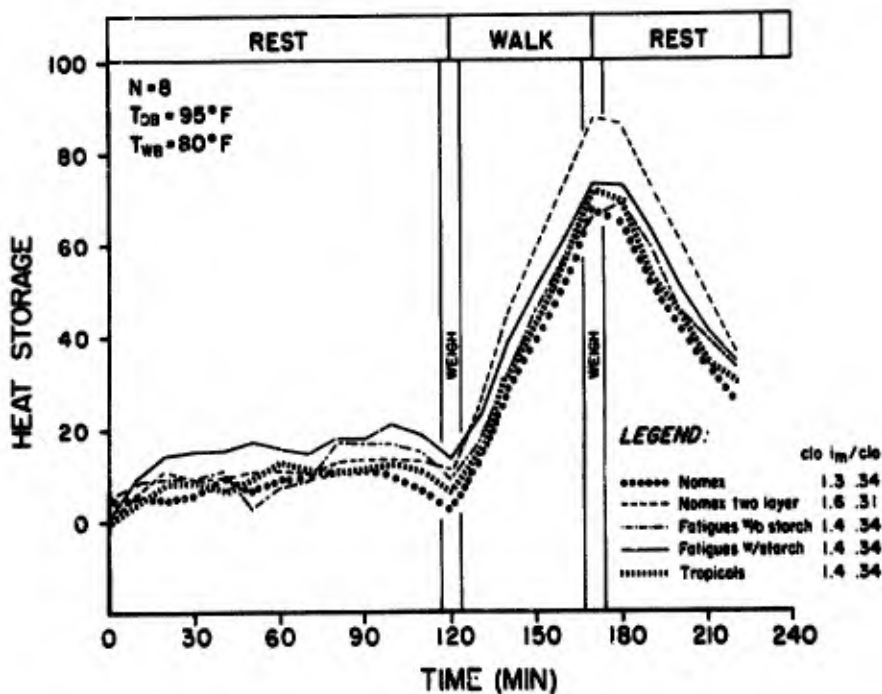

B. Uniforms of different fibres or finishes

Fig.5 The results of physiologic chamber studies presented as the body heat storage by men wearing various types of protection

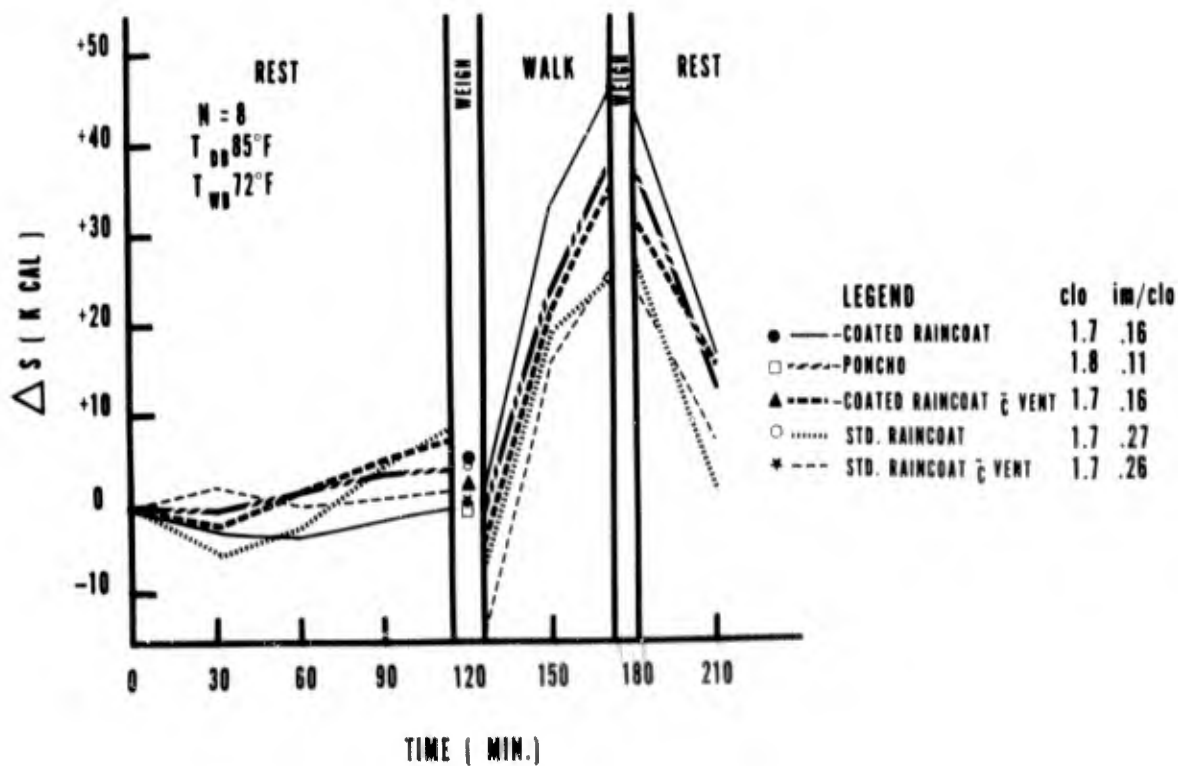

C. Permeable and impermeable raincoats with or without vents or of unusually loose fit (the poncho)

Figure 5 concluded

AIR CREW PROTECTIVE TECHNIQUES
FOR HOT HUMID ENVIRONMENTS

by

R. Gaudio, Captain, USAF, MC
M. McCally, M.D.
W.C. Kaufman, Lt Colonel, USAF
N. Abramson, M.D.

6570th Aerospace Medical Research Laboratories
Wright-Patterson Air Force Base, Ohio

SUMMARY

Cockpit temperatures of 54°C with 40-50% Relative Humidity are not unusual in Southeast Asia. In an attempt to minimize the physiologic changes that occur during exposure to such an environment three simple protective devices were studied: (1) a water cooled vest, (2) the effect of breathing cool-dehumidified air and (3) the administration of the steroid blocking agent - metapyrone^(R). In evaluation of each device, five subjects were exposed to heated environments similar to those encountered in Southeast Asia both with and without the addition of each of the protective devices. It is demonstrated that the water cooled vest significantly improves both thermal tolerance and the physiologic responses to a hot humid environment. Breathing cool dehumidified air significantly reduces the ventilatory response to heat stress but is not protective otherwise. Metapyrone administration reduces the excretion rate of sweat Na in response to heat stress but it also is not thermally protective.

AIR CREW PROTECTIVE TECHNIQUES FOR HOT HUMID ENVIRONMENTS

R. Gaudio, M. McCally, W. C. Kaufman and N. Abramson

INTRODUCTION

USAF personnel now operating in SE Asia may be exposed to daily summer temperatures of 33°C with 60-70% relative humidity. In addition to the high air temperature, the radiant heat load may raise cockpit temperatures as high as 54°C with 40-50% humidity. Many aircraft are flown under conditions in which air conditioning is inadequate and less sophisticated aircraft are not equipped with it⁽¹⁾. We have previously shown that in a 54°C - 49 mm Hg H₂O vapor pressure environment mean human tolerance is 37 minutes. Over this period, mean sweat loss is 900 cc, body temperature rises 3°C, minute volume increases 3 liters/min, striking respiratory alkalosis develops and tetany occasionally occurs⁽²⁾.

In an attempt to minimize such physiologic changes among aircrews, three simple and operationally feasible protective devices were evaluated. The first device investigated was a water cooled vest. Such a device has been previously described as protective⁽¹⁾ so that we have primarily extended study to its protective effect in hot humid conditions. The second protective device studied was that of breathing cool dehumidified air. It is known that inspired air temperatures and humidity may be a limiting factor for men working in heated environments. In mine rescue operations, self contained breathing systems are used to provide cool breathing air to personnel working in hot environments where breathing is intolerable. The available literature⁽³⁾ suggests that such devices may be thermally protective.

The third protective device studied was the oral administration of metapyrone^(R) - a propanone derivative that inhibits the synthesis of cortisol, hydrocortisone and aldosterone⁽⁴⁾. Subjects taking this drug as part of another study at our laboratory felt subjectively improved during heat exposure and heart rate responses were reduced.

METHODS AND RESULTS

All experiments were performed in the all weather chamber at the Aerospace Medical Research Laboratories, Wright-Patterson AFB, Ohio. Five normal unacclimated healthy male volunteers were used as subjects for each of three studies. They were weighed nude before and after each heat session.

During each of the three experiments, an on-line analog provided real time values for temperatures of 17 skin sites, rectal temperature, average skin temperature and body temperature. Electrocardiogram and heart rate were also continuously monitored.

The difference between pre and post exposure nude weight constituted total sweat loss. Heat storage was calculated using Burtons formula⁽⁵⁾. All delta values represent the difference between pre-exposure data and the data obtained at thermal tolerance and thus indicate the change in each parameter occurring during heat stress. The data obtained from two of the experiments was analyzed using Student's T test. The results of the metapyrone study were evaluated by the analysis of variance for the conditions of temperature and drug effect. In all experiments, a p value of less than .05 was accepted as statistically significant.

In evaluation of the water-cooled vest, the subjects were exposed to a 54°C - 49 mm Hg H₂O vapor pressure environment to subjective timed tolerance, which was defined as the point at which pre-syncope symptoms were felt to be intolerable by the subject. During the control session, the subjects were dressed in thermal underwear and summer flying suit only (1.0 Clo). During the study session, they were dressed the same except for the addition of the water-cooled vest.

Figure 1 merely depicts a subject wearing the water-cooled vest. The vest is made of a rubberized nylon stretch foundation which allows it to fit aircrew members with body surface areas of 1.6 to 2.1m². The vest has a total surface area coverage of 0.4m². The inner surface has a network of polyethylene water lines.

The flight system consists of a heat sink (ice chest) containing equipment necessary to pump H₂O from melted ice through insulated, flexible tubing to the garment. Flow rate may be varied to produce a vest inlet temperature from 5-21°C, and 3-4 Kg of ice per manhour is needed to maintain the desired temperature. In this experiment, a vest inlet temperature of 5°C was used.

During the heat exposure, minute volumes were collected by mask and Douglas bag and venous blood was drawn immediately before and after for pH and pCO₂.

Table I represents mean tolerance time, mean heart rate, mean rectal, average skin body temperature change, heat storage, sweat loss mean minute volume and pH changes during the 54°C heat stress with and without H₂O cooling. The left column indicates results with H₂O cooling during a mean exposure time of 44 mins, the middle column results with H₂O cooling during a mean exposure time of 81 mins, the right column the difference between the two. From Figure 2, it can be seen that water cooling significantly improves tolerance time by 37 mins. At the same time, there is a significant reduction in heart rate of 25 beats/min. Rectal temperature fell minimally but delta skin temperature is significantly reduced 3.9°C and delta body temperature 2.00°C as a result of water cooling. Correspondingly, there is a significant reduction in heat storage of 46.7 Kcal/m² as a result of water cooling. Turning now to sweat loss, it can be seen that sweat loss over a 44 minute exposure was 597 gms without water cooling and 1150 gm over an 81 minute exposure with water cooling. Clearly, in this environment then water cooling is not protective with respect to sweat loss. In earlier preliminary studies in a 46°C - 15 mm Hg H₂O vapor pressure environment, however, we found that sweat loss over a 2 hr period was significantly reduced from 750 gm to 220 gm and evaporation increased from 67 to 76% with the addition of H₂O cooling.

Though the difference is not significant, mean minute volume change during heat exposure is reduced 2.5 liters per min with water cooling. Correspondingly, there is a slight but significant reduction in delta pH of .046 units.

It can be said then that water cooling significantly improves thermal tolerance and reduces the heat load. It also reduces both the physiologically deleterious tachycardia and the hyperventilation that occur during heat stress. When compared to controls over similarly timed moderate heat exposure, it effectively reduces sweat loss, however it does not do so in a hot humid environment.

To study the thermal protectiveness of breathing cool dehumidified air, subjects, dressed in 0.3 thermal underwear only, were again exposed to a 54°C - 49 mm Hg H₂O vapor pressure environment to subjective timed tolerance. During the control session, they breathed ambient air through a mask where air temperature at the inlet valve was 45°C. During the study session, they breathed 27°C - 10 mm Hg H₂O vapor pressure air supplied at constant low flow from an air conditioning unit. Minute volume and respiratory rate were continuously monitored and venous blood was drawn for pH and pCO₂.

Turning now to the results, Figure 3 demonstrates mean minute volume during heat stress. The abscissa is percent of total tolerance time with pre and post exposure periods on either side of the dotted lines. The ordinate is mean minute volume in liters/minute. Each point represents mean minute volume and the brackets ± 1 standard error. The small dotted line is minute volume at 54°C while breathing ambient air (45°C). The solid line is minute volume at 54°C while breathing cool air (27°C). Also added from comparison is the large broken line which represents minute volume during a 27°C heat exposure while breathing 27°C air. From the results it can be seen that at 54°C, minute volume while breathing 27°C air is reduced throughout the heat exposure below minute volume while breathing 45°C air though significant differences exist only at 40 to 60% of tolerance.

Table II represents mean tolerance time, mean heart rate, rectal temperature change, sweat loss and pH change from control during a 54°C - 49 mm Hg H₂O vapor pressure heat stress while breathing ambient (45°C) air and cool (27°C) air. The left panel contains results breathing ambient air, the center panel results breathing 27°C air and the right panel the difference. From these results it can be seen that breathing cool dehumidified air does not significantly improve tolerance time, delta heart rate, delta rectal temperature, sweat loss or delta pH. In addition the rate of rise of rectal and body temperature is not significantly reduced by breathing cool air.

On the basis of these results it can be said that breathing 27°C - 10 mm Hg water vapor pressure air significantly reduces the ventilatory response to heat exposure but not enough to prevent the development of respiratory alkalosis or reduce its severity significantly below control levels. It is not of course an effective protective device.

During the metapyrone evaluation, the 5 unacclimatized subjects took either (1) 4.5 gm metapyrone orally, (2) a sucrose placebo or (3) no drug, on the day prior to an experiment. This was done by a double blind method. Each subject was then studied in a 27°C control session and a 46°C 15 mm Hg water vapor pressure heat session for 3 hrs on different days and in random fashion. During each session, arm sweat was collected every 45 min. Venous blood and urine were collected before, during and after each exposure. Sweat, blood and urine were analyzed for osmolarity, Na, Cl, K, creatinine and urea nitrogen. In addition, blood and urine steroid and catecholamine levels were determined.

Examination of the results reveal that with metapyrone administration, sweat sodium rate is significantly decreased during the last 90 min of heat exposure when compared to no drug administration. It is also decreased in comparison to the placebo administration but the difference is not significant. Robinson⁽⁶⁾ found that desoxycorticosterone administration to men undergoing acclimitization to heat similarly reduced the sweat Na. This is of interest with respect to our study because metapyrone administration, by blocking 11 β -hydroxylation in steroid synthesis, inhibits cortisol production and hence normal negative feedback to the pituitary gland. This absence of feedback increased ACTH production which in the face of a metapyrone blockade of otherwise normal steroid synthesis increases the output of desoxycorticosterone, a potent mineralocorticoid normally produced in small amounts by the adrenal gland⁽⁴⁾. It is likely then that the reduced sweat Na rate seen with metapyrone is mediated by endogenous desoxycorticosterone.

Turning now to other results it is found that under the conditions of this experiment none of the other parameters measured are consistently altered by metapyrone administration with the exception of urinary steroid results which are consistent with effective metapyrone blockade. It must be concluded, therefore, that while the results are extremely interesting from a physiologic point of view, they demonstrate that metapyrone is not a thermally protective drug.

In summary, it is demonstrated that a water-cooled vest offers significant thermal protection. It significantly improves tolerance in a severe environment, at the same time reducing both the indices of heat stress and the heat induced hyperventilation. In a moderate environment, it reduces sweat loss and increases evaporation but it does not appear to do so under hot-humid conditions.

Breathing cool dehumidified air reduces the ventilatory response to heat stress but it is not a thermally protective device otherwise.

Lastly, metapyrone administration, while producing interesting physiologic changes, also demonstrates no thermal protection.

REFERENCES

1. Kauffman, W.C., and Pittman, J.C., "A simple liquid cooling system for aircrew-members", AMRL TR-66-48, W-PAFB, Ohio.
2. Gaudio, R. and Kissen, A.T., "Heat induced hyperventilation and tetany", The Physiologist. Vol.10:177, August 1967.
3. Lind, A.R., "The influence of inspired air temperature on tolerance to work in heat", British Journal of Industrial Medicine. Vol.12:126, 1955.
4. Gannt, R., Chart, J.J., and Renzi, A.A., "Endocrine pharmacology", Science Vol.133:613, 1961.
5. Burton, A.C., "The average temperature of the tissues of the body", Journal Nutrition. Vol.9:261, 1935.
6. Robinson, S., Kincaid, R.K., and Rhaney, R.K., "Effects of desoxycorticosterone acetate on acclimitization of men to heat", Journal Applied Physiology. Vol.2:399, 1950.



Fig. 1

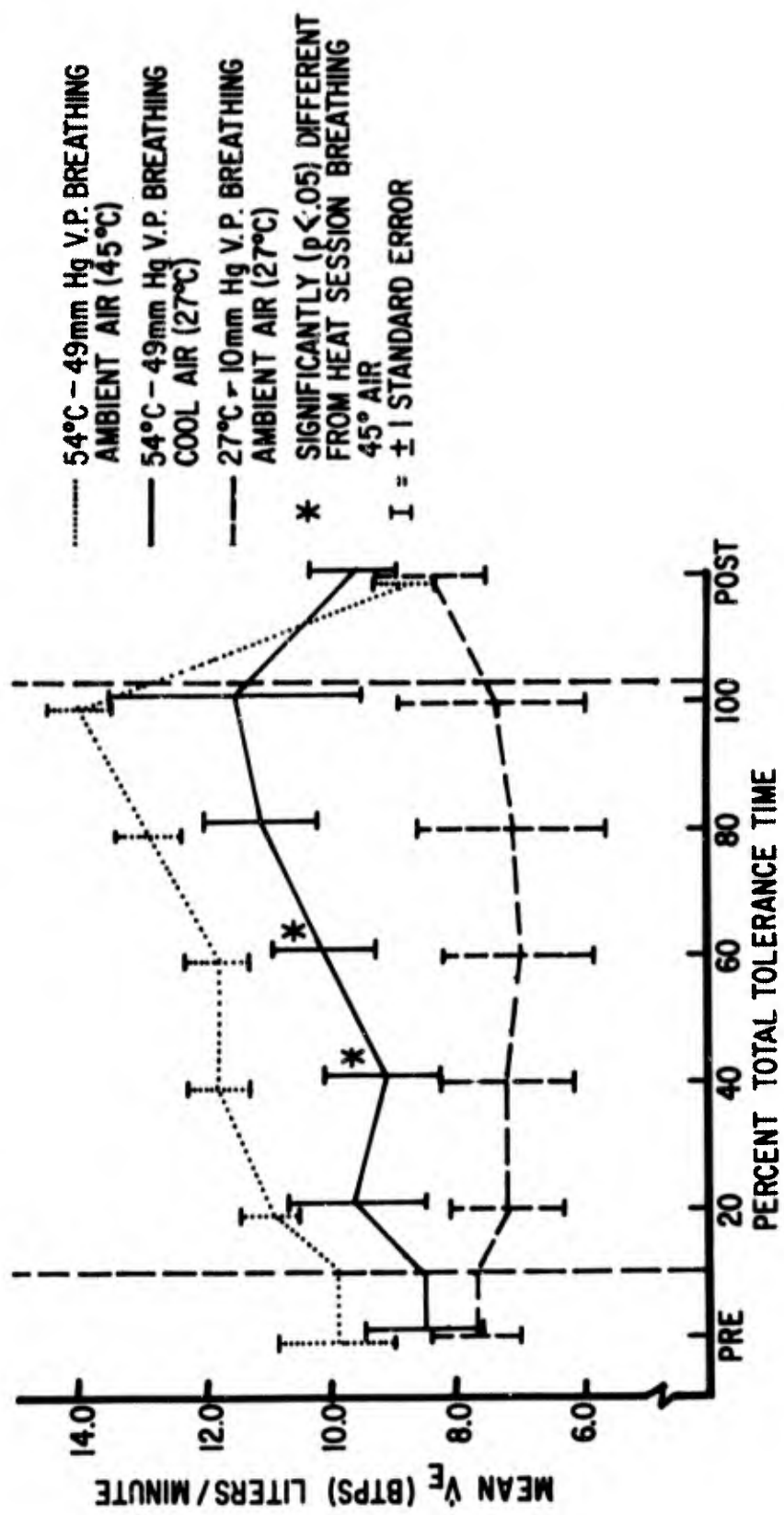

Fig. 2 Mean minute volume (\dot{V}_E) during heat stress

TABLE I

Mean Tolerance Time, Heart Rate and Temperature Changes, Heat Storage, Sweat Loss, Change in Minute Volume and pH During Heat Stress

	WITHOUT VEST	WITH VEST	DIFFERENCE
MEAN TOLERANCE TIME (Minutes)	44±5 ¹	81±10	37±8*
MEAN Δ HEART RATE (Beats/Min)	61±9	37±4	24±4*
MEAN Δ RECTAL TEMPERATURE (C)	1.11±0.28	0.94±0.11	0.17±0.16
MEAN Δ SKIN TEMPERATURE (C)	7.90±0.33	4.00±0.39	3.90±0.50*
MEAN Δ BODY TEMPERATURE (C)	3.39±0.16	1.30±0.22	2.00±0.50*
MEAN HEAT STORAGE (Kcal/M ²)	103±5	56±6	47±10*
SWEAT LOSS (Grams)	597±38	1150±204	553±228
MEAN Δ MINUTE VOLUME (Liters/Min)	4.1±0.6	1.6±1.3	2.5±1.8
MEAN Δ pH	0.12±0.02	0.07±0.002	0.05±0.02*

* = P < .05

1 = ±1 Standard Error

TABLE II

Mean Tolerance Time, Mean Heart Rate, Rectal Temperature Changes, Mean Sweat Loss, and Mean pH Change During Heat Stress

	BREATHING 45°C Air	BREATHING 27°C Air	DIFFERENCE
MEAN TOLERANCE TIME (Minutes)	40±5 ¹	44±10	4±3
MEAN Δ HEART RATE (Beats/Min)	60±4	55±4	5±3
MEAN Δ RECTAL TEMPERATURE (C)	0.95±0.28	1.00±0.16	0.05±0.16
MEAN SWEAT LOSS (gms)	1368 ± 239	1050 ± 146	318 ± 212
MEAN Δ pH	0.10±0.03	0.09±0.02	0.01±0.03

1 = ±1 Standard Error

**RECENT ADVANCES IN THE DEVELOPMENT OF MEDICAL
EQUIPMENT AND MATERIEL FOR MILITARY
AEROSPACE OPERATIONS**

by

**Captain John E. Murphy, USAF, MSC
Major Bruce H. Warren, USAF, MC**

**Aerospace Medicine Division
Directorate of Research and Development
Aerospace Medical Division (AFSC)
Brooks Air Force Base, Texas**

BLANK PAGE

RECENT ADVANCES IN THE DEVELOPMENT OF MEDICAL EQUIPMENT AND MATERIEL FOR MILITARY AEROSPACE OPERATIONS

Captain John E. Murphy, USAF, MSC
Major Bruce H. Warren, USAF, MC

1. INTRODUCTION

During the past two years the Aerospace Medical Division of the United States Air Force Systems Command has magnified its effort to develop items of medical equipment for the improvement of medical care and treatment in aerospace operations. Research efforts have taken place in both the exploratory (applied) and engineering development areas. Several tasks have been initiated as the result of operational requirements stated by major commands of the United States Air Force through the USAF Surgeon General's Office while others germinated from the original thoughts and efforts of individual scientists in various laboratories of the Aerospace Medical Division.

Much energy has been expended toward exploratory and engineering development in two main operational areas -- the facilities needed to provide medical support at remote and logistically isolated "Bare Bases" (1), and, secondly, the medical equipment used in the movement of patients in the USAF Aeromedical Evacuation System. This discussion concerns recent advances being made by the Aerospace Medical Division in the development of aerospace medical equipment and materials for these two important areas. These developments represent both in-house and contractual efforts.

2. THE "BARE BASE"

"Bare Base" is the term used to designate an objective area to which U. S. Air Forces would deploy in support of contingency operations. The "Bare Base" is generally characterized by being a logistically remote and isolated area, at least in the initial stages of operation. By definition, it has an airstrip, a source of water, and nothing else. The combat operations to which the Bare Base relates are the deployed tactical air forces.

2.1 Medical Services at "Bare Bases"

The mission of the medical services in support of Air Force "Bare Base" operation is to provide modern, effective medical support under all conditions (5). Provision of immediate and effective medical support is a prerequisite to successful mission accomplishment and contributes directly to the "flexibility" of tactical Air Forces (2). To support these operations, the USAF Medical Service requires the medical capability needed to: support the specified force levels (500 to 3,500 military personnel); deploy upon 24 hours notice; be ready to receive patients within a few hours after arrival at the objective area; and be fully operational within eight hours. At a "Bare Base", a limited inpatient capability is provided to hospitalize patients for short periods. Essential medical service functions needed to support the deployed operational forces are:

- Outpatient treatment
- Aerospace medicine
- Laboratory
- Pharmacy
- X-Ray
- Dental treatment
- Inpatient capability
- Surgery
- Central medical supply
- Preventive medicine

2.2 Air Transportable Self-Contained Tactical Treatment Facilities System

Presently under development at the Aerospace Medical Division is a new Air Transportable Self-Contained Tactical Treatment Facilities System. This facility embodies the most advanced professional and technical devices ideally positioned for use in the most suitable shelter environment conducive to patient recovery and worker efficiency. The medical facilities consist of six separate subsystem structures, each functionally identified by the primary capabilities it implements. These are a medical dispensary; a combination laboratory/x-ray service; 8-bed medical/surgical wards; a surgery; a combination pharmacy/central and medical supply; and a dental operatory.

Each subsystem structure is designed as a self-contained module, employing an expandable container that in the closed configuration will have a common rigid external shape and dimension. In the closed configuration the shelter provides storage for the integral components in a

ready state and serves as a shipping container for transport purposes. When expanded, each container becomes a fully air-conditioned (heated, cooled, ventilated) shelter with functionally designed work areas complete with utility distribution and plumbing hardware integrated into the shelter. From the shipping size of 8 x 8 x 13 feet, the container expands into a structure with 400 square feet of usable floor space.

There is adequate storage space in the transport mode to carry sufficient medical support for a "Bare Base" population of 2,000 military personnel for time periods up to 45 days without resupply of consumables. All equipment is designed for up to 180 days of maintenance-free operation. These stringent design characteristics were necessary because of the self-sustaining and self-sufficiency requirements of the "Bare Base" operation. The medical facilities are designed for compatibility with the "Bare Base" community complex and common families of support equipment, such as electrical power generators are used. Food service, laundry, communication and sewage disposal functions are provided from the "Bare Base" support complex.

The system is designed for easy and rapid transport and positioning. It can be deployed in three C-130 size aircraft. In keeping with USAF mobility concepts, the facilities are designed primarily as air transportable structures, with ground mobility performance being limited accordingly. Of particular importance is the capability to tailor the medical support to the particular operation. Each subsystem module is designed for independent employment to produce the size and kind of facility best suited for each situation and population level to be served.

This high priority development project of the Aerospace Medical Division will soon provide a field medical treatment system that will substantially enhance the capability of the USAF Medical Service to provide the best possible care and treatment to the military personnel of the Air Forces, at any location, in all climates, worldwide. The present schedule is to complete the technical tests and evaluations by the fall of 1968. When placed into the inventory of the operating commands, the Air Transportable Self-Contained Tactical Treatment Facilities System will significantly contribute to the "fightability" of Air Force operational forces by providing a high level of medical capability to keep the military man "on the line" insuring a high level of mission accomplishment.

3. AEROMEDICAL EVACUATION

Increased emphasis has been placed this past year in research efforts

supporting the USAF Aeromedical Evacuation System. Although the concepts of aeromedical evacuation have long been known, the combination of hostile action in Vietnam and the use of modern jet aircraft have brought the method of patient handling into a new and clearer prospective.

Experience in aeromedical evacuation has clearly demonstrated that any patient that can be moved can safely be transported by air providing a qualified aeromedical crew performs the mission, the patient is properly prepared prior to flight, and necessary medical equipment (standard as well as special) is available to meet the needs of the patient during the flight (6, 7). Significant new efforts have occurred this past year to enhance the third variable, medical equipment for aeromedical evacuation.

The need for development of medical equipment for utilization in the airborne situation is quite obvious when we analyze the factors involved (4).

- a. The interior space of an aircraft in an aeromedical configuration is at a premium.
- b. The available aircraft power source is restricted to 24-volt direct current.
- c. Vibrations in-flight frequently disturb the efficacy of medical equipment.
- d. The possibility of rapid decompression at altitude with its effects on the integrity of medical equipment is a continuous problem.
- e. The in-flight operations are in a high noise level environment (3).
- f. Medical equipment must not interfere with the aircraft instruments or navigational equipment.
- g. Medical equipment for aeromedical evacuation must withstand higher G levels.

For the first time in history the jet age makes it possible to transport American casualties 8,000 miles right from the battle front to a definitive care hospital in the United States in as little as 72 hours or less. Air Force jet aircraft are used to transport patients from Saigon to Washington, D. C., in 20-1/2 hours by way of the Polar route. Casualties from Clark Air Base in the Philippines, having received intensive short term care, are transported in 13 hours to the West Coast of the United States. The

need to develop special medical equipment for aeromedical evacuation is not limited to the air transportation of war casualties. Patients with severe burns are flown to the Army Burn Center quite routinely, and, in the past, polio victims have been flown in the SAM lung to polio centers. These flying hospital wards must have on board the same type of medical equipment needed in hospital emergency rooms or hospital wards.

Some medical equipment developments for airborne use that have been produced by the Aerospace Medical Division are summarized as follows:

3.1 Sphygmomanometer

Problem/Need: The present sphygmomanometer-stethoscope method for measuring blood pressure is unsatisfactory in noisy environments. The use of existing sphygmomanometers with digital palpation of the pulse is generally inaccurate in determining systolic pressure, and diastolic pressure cannot be determined at all. The lack of a sphygmomanometer that can accurately measure blood pressure of patients aboard aircraft or in areas where ambient noises cannot be controlled prevents medical personnel from obtaining quantitative medical data relating to a patient's condition. This lack effectively limits simple medical monitoring by depriving medical personnel of valuable diagnostic and/or prognostic information.

R&D Effort: In-house development of an electronic sphygmomanometer simple in design, usable with standard cuffs capable of visual and auditory recording of systolic and diastolic pressure, with a gauge insensitive to barometric pressure differentials is nearing exploratory completion. In-flight tests indicate that the augmented sounds of blood pressure are perceptible on board jet and reciprocating engine aircraft.

3.2 Portable Oxygen System

Problem/Need: Several multi-mission aircraft used to fly aeromedical evacuation missions do not have integral oxygen systems in the cabin area (C-118, C-97, C-130, C-131, C-7). When these aircraft fly aeromedical missions, oxygen resources must be brought aboard, either in the form of the large pressure tank (2200 psi) or several portable bottles (walk-around). The PACAF Surgeon reported that the availability of oxygen resources became a limiting factor when the workload of aeromedical evacuation within the theater increased because of hostile action in Southeast Asia.

R&D Effort: Evaluation of an off-the-shelf "Portable Cryogenic Oxygen System" showed that with engineering modifications this system could be utilized for aeromedical purposes. The modified system is capable of providing oxygen to two patients continuously and simultaneously at an oxygen flow rate of 8 to 10 liters per minute per patient for eight hours. The system can be recharged from standard USAF oxygen service trailers, is designed for compatibility with respiratory support equipment, and can be purged using standardized methods and equipment. The system is of a size (24-1/2" high, 13-1/2" wide, and 12" deep) that it will fit the available space between litter tiers in various aircraft. It weighs 47 pounds when fully charged and can be secured in place aboard the aircraft (no power source required). The logistic problem of providing oxygen for aeromedical evacuation on a world-wide basis is virtually eliminated by the development, as it is anticipated that these units will be inherent to aeromedical evacuation squadrons.

3.3 Bacterial Isolation Unit

Problem/Need: The transportation of patients whose conditions require application of isolation techniques and procedures presents several problems during flight. Isolation or so-called "reverse isolation" (for burn patients) is difficult at best with present methods when moving patients with a contagious stage of a communicable disease, burns, or gas gangrene.

R&D Effort: Recently developed after a two-year effort is a Bacterial Isolation Unit (BIU) that is bacteriologically sound, adaptable for a single patient, transportable on ambulance buses and aboard aircraft, and of a size that facilitates portability. It contains a power system compatible with aircraft and ground power systems and can also operate independently. The unit consists of two subsystems:

- a. A reusable environmental control unit that regulates heat, oxygen and humidity levels. Temperature ranges from 65° to 85°F can be maintained.
- b. A disposable transparent patient enclosure designed to facilitate medical treatment and nursing care.

Air entering and leaving the enclosure is filtered and deodorized. Ultra-high filters are contained in disposable plastic end boards. A working laboratory model of this unit has undergone extensive and intensive testing and evaluation by the scientific staff at the USAF School of

Aerospace Medicine. Tests have demonstrated that with this unit patients with burns, active pulmonary tuberculosis, cystic fibrosis, gas gangrene or any condition requiring a stable environment can be transported by air anywhere in the world in an optimal environment that is controlled, safe, and comfortable.

3.4 Humidifiers-Nebulizers

Problem/Need: Relative humidity aboard jet aircraft (C-141) ranges from 3% to 25%. These low levels of humidity dry mucosal surfaces and thicken tracheal secretions of patients who have a tracheostomy. As an interim measure the heat-moisture-exchangers (HME) or "artificial noses" have been utilized. However, the problem posed by low humidity atmospheres encountered in pressurized aircraft continued to be pressing and hazardous to patients with tracheostomies, burns, pulmonary problems, and those in coma. Exposure to dry cabin environments eventuating airway membrane dissociation and pulmonary complications required a more aggressive approach than HME provided.

R&D Effort: An in-house evaluation of off-the-shelf humidifiers/nebulizers showed that with some engineering development such as in size and incorporation of a power source compatible with existing aircraft power sources (24V DC) that a commercially available unit could meet the requirement for increased humidity aboard aircraft. This unit was re-engineered and has been miniaturized to facilitate placement between litter tiers, reduce weight to 13 pounds, and increase portability. The unit has a simple air flow control valve to control amount of mist or vapor delivered to the patient.

3.5 Patient Litter Pad

Problem/Need: The problem of litter pads for aeromedical evacuation was identified by the Surgeons of MAC and PACAF. This logistic back-haul of litter pads intensified the need for development of a comfortable but disposable litter pad within economic reasons.

R&D Effort: A litter pad covered with a material impervious to body excretions and/or secretions was developed. Shelf life of this item is indefinite as materials are inert. The pad has proven to be comfortable, can be reused, and its buoyancy makes it possible to use it as a flotation device. The pad weighs 5.28 pounds when stored, 5.63 pounds inflated, versus the 15-pound weight of the present pad being used. In rough order

of magnitude, cost in quality of new pad would be one-half the cost of the present listed federal stocked item.

3.6 Litter Support System

Problem/Need: The present method of supporting litters aboard aircraft provides extremely limited accessibility to the patient when care or treatment is given. When enplaning litter patients the litter tier must be loaded from the top down and in deplaning patients the bottom litter must be off-loaded first. Furthermore, the present litter-carrying method which utilizes brackets and web strapping does not provide litter patients with the opportunity to "walk away" from a survivable accident.

R&D Effort: A major breakthrough for improving litter carrying capability has been accomplished. This system eliminates brackets and web strapping. Patients can be enplaned or deplaned in any sequence which permits placing patient in a shock or semi-Fowler's position in that the litter ends can be lowered or raised. The system provides greater patient accessibility by enabling the flight nurse to pull the litter out from the closed position toward the aisleway to either partial accessibility (example: suctioning) to complete accessibility (example: for changing a dressing located on the far side (outboard) of the patient). The design loadings of the litter support system for crash conditions are:

8 G - forward
3 G - aft
3 G - up
4-1/2 G - down

The litter support system can be used on C-141 aircraft without any modifications and can be readily adapted to the C-130. Litter arms swing 90° to either side to allow full access to aisleway during enplaning or deplaning of the patients. This system will decrease present time required for enplaning or deplaning patients.

3.7 Patient Access Unit

Problem/Need: During contingency actions, limited war, or peak load periods when optimal utilization of space aboard aircraft is required, four litters per tier must be employed. In this configuration the height of the tier makes even simple medical care difficult and obviates efficient medical observation of the patient during flight. When a patient in the

third or fourth litter requires care and attention, the flight nurse or technician stands on whatever item of cargo is available.

R&D Effort: An effort to develop a stable, safe, and corrosive-resistant litter access unit designed with pertinent human and safety engineering factors is now in progress. The unit is easy to install, remove, and simple in mechanical design. It has been designed with a platform to hold medications and miscellaneous medical supplies.

3.8 Intensive Care Unit

Problem/Need: A goal of the aeromedical evacuation system has been to increase in-flight medical capability for patients requiring intensive care without seriously affecting present capability for transporting other patients.

R&D Effort: A feasibility study is now underway to develop an airborne intensive medical care unit (ICU) that will provide aeromedical crew members with the in-flight capability to administer proper medical care to critically ill patients as well as provide rapid response to emergencies which occur in-flight. This effort will establish ICU design and operational requirements. The second phase of this effort will be the engineering and fabrication of the unit.

4. SUMMARY

Exploratory and engineering development of medical equipment has been accelerated the past year in both in-house and contractual efforts. Significant advances have been achieved in providing improved equipment for the Aeromedical Evacuation System. Recent advances include the development of a functional sphygmomanometer; portable oxygen system; bacterial isolation unit; humidifier-nebulizer; litter support system; patient access unit; and exploratory study of an intensive care unit. An Air Transportable Self-Contained Tactical Treatment Facilities System is under development and will soon provide the United States Air Force Medical Service with an enhanced capability to provide the best possible medical care and treatment to military personnel of the Air Force, at any location, in all climates, world-wide.

REFERENCES

1. Bare Base Support Task Force Report, Aeronautical Systems Division, Wright-Patterson AFB, Ohio, April 1966.
2. Concept and Design Conference, "Air Force Field Medical Treatment Facility", Brooks AFB, Texas, June 1966.
3. Gasaway, Donald C. Noise environments encountered within two- and four-engine powered fixed-wing aircraft: influence of power plant and power plant-to-vehicle matings on the character of internal noise. Oral presentation, Acoustical Society of America, 3 November 1966.
4. McFarland, R. A. Human factors in air transportation. New York: McGraw-Hill, 1953.
5. Mobility Planning. Tactical Air Command Manual 400-1. Langley AFB, Virginia, February 1966.
6. USAF Flight Surgeon's Manual. Air Force Manual 161-1. Department of the Air Force, Washington, D. C., 1962.
7. USAF School of Aerospace Medicine Flight Nursing Manual, Brooks AFB, Texas. Third Edition.

FLASH BLINDNESS
DEVELOPMENT AND TRIALS OF PROTECTIVE SPECTACLES

by

Lt Colonel Bryan St L.Liddy, CD, RCAMC and Clement McCulloch, M.D.

Canadian Forces Institute of Aviation Medicine
1107 Avenue Road
Toronto 12, Ontario, Canada

**FLASH BLINDNESS
DEVELOPMENT AND TRIALS OF PROTECTIVE SPECTACLES**

Bryan St. L.Liddy and Clement McCulloch

INTRODUCTION

In the paper "Preserving Vision despite Exposure to High Intensity Light"¹ which was delivered at last year's AGARD Meeting, Dr. McCulloch introduced the concept of preserving visual function by protection of non corresponding retinal points. This was to be achieved by shading the temporal half of each retina from incident light. Glasses which would do this resemble the old fashioned horse blinkers and will be referred to as blinker type glasses in this paper. With such glasses, the field of vision left to the wearer is 60° plus in the straight ahead position looking towards infinity, whilst full stereopsis and fusion is maintained for near tasks such as map reading and instrument check (Fig.1). The field retained, therefore, meets the NATO Stanags for the critical flight instrument placement.

A tactical situation that exposed low flying pilots to multi detonations of small yield weapons within a relatively short period of time was the one that was envisaged for Canadian pilots. By wearing the blinker type glasses it was felt that at all times uninterrupted macular and hemiretinal function would be maintained by one or other eye despite exposure to scotoma-producing high intensity light. Therefore, aircraft control would not be impaired by temporary visual loss.

PROBLEMS

The Canadian Forces Institute of Aviation Medicine was given the task of further development and testing of this concept. Two problems were considered primary -

- (1) that the glasses would in fact protect against high intensity light; and
- (2) that the glasses would be compatible with flight safety.

In other words, we wished to ensure that wearing blinker type glasses did not add a greater hazard to pilot performance than would the possibility of flash blindness. It is with the latter that we will first deal.

Restriction of peripheral vision does create a hazard to flight safety and this particularly applies during the take-off and landing part of flight. It was felt that restriction of vision at that time was unacceptable. Any glasses developed, therefore, had to have certain characteristics of design -

- (1) they must be capable of being put on and taken off in flight; their actual use was to be restricted to that period of flight when it was decided that a flash blindness hazard did exist. It was intended that these glasses be cockpit, not personal, equipment;
- (2) they must be capable of being worn with the current RCAF helmet and oxygen mask;
- (3) their use must not interfere with the acoustic seal and cause radio interference; and
- (4) they must be stable under the influence of "G".

DESIGN

The present RCAF aircrew glasses were unsuitable because the temple bar is of the cable type and can not be put on or off during flight. The glasses popular in the USAF were also unsuitable because their spatulate type temple bar is too malleable to be inserted under a helmet without prolonged struggle. We, therefore, reviewed the commercially available frames to see which could be modified to suit our requirements. We quickly settled on a frame of French design as being most suitable. Its major selling point was that the temple bar could be inserted with the helmet in place. The other feature which made this frame suitable was the adjustable nose pad which allowed personal flush fitting and no interference with the oxygen mask.

Testing done at the Defence Research Establishment Toronto acoustic laboratories revealed that if a wearer had a properly fitting helmet, which we assumed all RCAF pilots have, there was no interference with the acoustic seal. Tests on the CFIAM accelerator with test forces in the region of 6G were done. No shift in frame position relative to the eyes or oxygen mask could be detected. This frame, therefore, was selected to carry the shaded lens.

Shading of the lens next attracted our attention and by experimenting with various readily available commercial techniques, an Italian process of impregnation of glass, commercially called "Surfcoting", was found adequate. A single coat of Surfcoote Brown on each side of the glass lens gave an optical density of 3, well within the density of the existing gold plated visor currently in use. It was, therefore, with surfcoted lenses mounted in the French frame that further testing for effectiveness of protection and compatibility with flight were done (Fig.2). It has since been found that shading the lens with a single coat of black lacquer paint would have been just as effective and considerably cheaper.

TESTING

The blinker glasses were tested for effectiveness against high intensity flash, using as our criteria for protection (1) ability to read 6/18 line on a test chart, and (2) ability to check and correctly read flight instruments in a simulated cockpit.

The light source used was unsophisticated but practical consisting of a series of N22 aluminum foil bulbs with a peak luminance of 4,200,000 lumens and a duration time

of 50 milliseconds. The incident lights were so arranged that they could be fired singly, coupled in batteries of two or three, or successively by use of an electronic timer. In this way intensity and duration of the light could be shortened or prolonged as desired.

Our ten subjects were all people possessing uncorrected visual acuity of 20/20 in each eye and all had preliminary fundoscopic examination to exclude pre-existing macular pathology. They sat centrally on a platform which was marked off in 10° radii and which had the firing sites marked at 70 cms on each respective radius. Thus obliquity of incidence in relation to foveal fixation was controlled. The background illumination varied between 2-10 ft candles.

RESULTS

The ten subjects had an unprotected 6/18 recovery time of between 34-150 seconds, the average being 43 seconds. Following initial flash, the tests were then repeated with the blinker glasses and recovery then measured either by the 6/18 visual angle criteria or by instrument reading ability. All our cases showed fairly consistent results with recovery times in the neighbourhood of 2-3 seconds being achieved as long as foveal exposure was not complete. The angle of incident light made little difference as long as it subtended more than 10° from central fixation using the 6/18 visual angle criteria. It was, however, observed that increasing the angle of incidence decreased the time of recovery if one used a 6/6 reading ability as the criteria. When tested in a simulated cockpit results were parallel but it was here that differences between the protected and unprotected state from obliquely incident flashes was manifest. If a series of rapidly successive flashes were set off so that the subject seated at zero incurred many oblique scotoma his ability to overcome them and read particularly non central instruments was impaired with recovery times of between 15-30 seconds being recorded. With blinker glasses in place no such impairment was noted in the non illuminated cockpit conditions used in the experiment; recovery being present in 2-3 seconds in all cases. Head movement required in this manoeuvre is considerable. This constitutes a definite problem as it could induce disorientation in certain circumstances. Dark adaptation is lost.

FLIGHT TRIALS

Attention was next directed to testing the glasses in flight. Because of the potential hazards involved, the programme proceeded cautiously. It has involved three stages -

- (1) flight trials in Class B & C piston aircraft flying mainly over the vast water body of Lake Ontario;
- (2) flight trials utilizing dual cockpit jet trainer aircraft; and
- (3) trials involving the CF 104 aircraft in its normal strategic locale.

RESULTS

The Trials 1 and 2 are complete whilst the final analysis of Trials 3 are still being done but sufficient data has been accumulated to state -

- (1) it is feasible to wear blinker type glasses in flight should this be required;
and
- (2) pilot acceptance of this type of protective device will depend to a large degree on familiarity with the glasses, coupled with a continued unit training programme stressing the nature and consequences of flash blindness as well as the protective techniques currently available.

CONCLUSION

Protection against scotoma-producing high intensity light flashes can be afforded by using spectacles with bitemporal shading of lens. Flight trials have demonstrated feasibility of their use in RCAF high performance aircraft. Increased pilot hazard which must be expected from any unnatural visual barrier such as these glasses are, can be reduced by adequate pre-use familiarization. However, at all times the comparative risks of flash and other hazards must be balanced when deciding on protective measures.

REFERENCE

1. McCulloch, C.
Elder, J.R. *Preserving Vision Despite Exposure to High Intensity Light.* AGARD Conference Proceedings No.11 1966, pp.121-133.

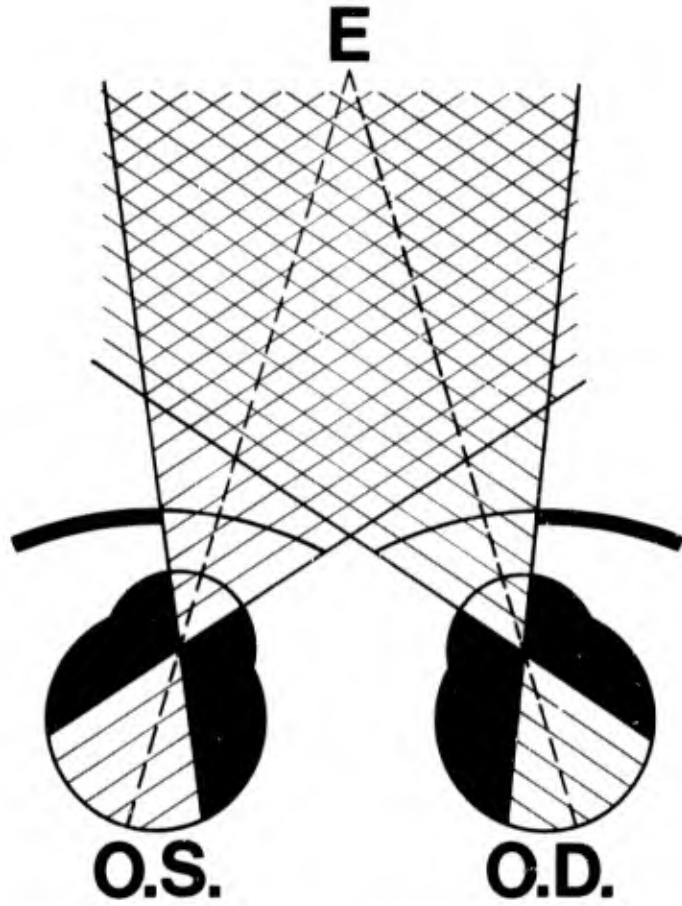

Fig.1 Retinal illumination from infinity

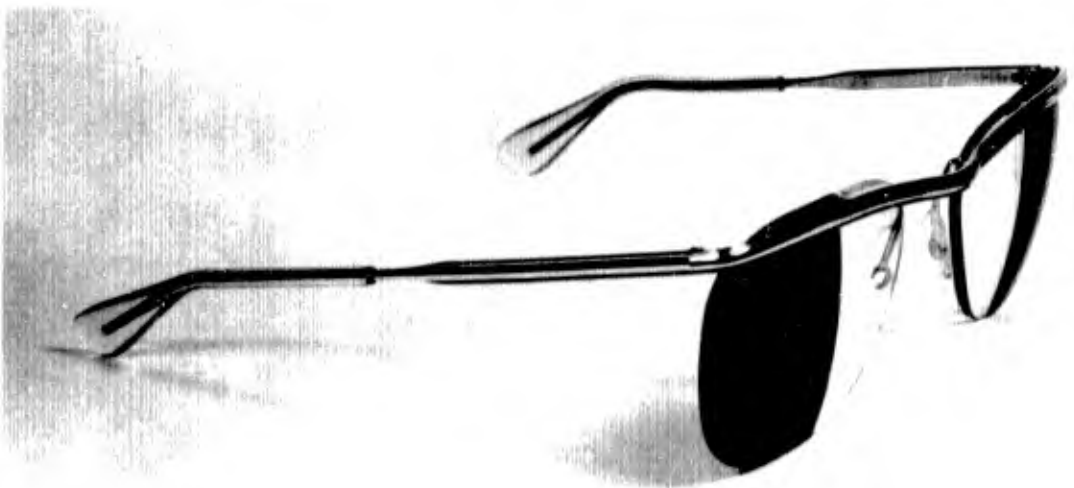

Fig.2 Protective Glasses

A REVIEW OF SOME RECENT AND CURRENT
EXPLORATORY DEVELOPMENT EFFORTS IN PRESSURE SUIT
TECHNOLOGY

by

Major Erwin R. Archibald, USAF

6570th Aerospace Medical Research Laboratories,
Wright-Patterson Air Force Base, Ohio

SUMMARY

The fundamental problem in pressure suits is that they limit the wearer's capability to perform useful work. Certain physiological problems are always potentially present since the pressure suit must provide adequate oxygen, removal of carbon dioxide, and thermal balance. For extended extravehicular activity, great increases in mobility are required in pressure suits. The problem of finding ways to increase the mobility of pressure suits is further compounded by the necessity to provide additional protection from unique hazards of the space environment, e.g., thermal extremes, electromagnetic radiation, and micrometeoroid particles. Most methods of providing the additional protection must, of necessity, further decrease pressure suit mobility. Fundamental considerations that apply to the design of all pressure suits were briefly considered. Some advantages and disadvantages of the four primary types of full pressure suit joints were considered. The current status of the "Boyle's Law" partial pressure suit was described. Research and development efforts leading to conceptual design of a hybrid second generation extravehicular space suit were reviewed.

A REVIEW OF SOME RECENT AND CURRENT
EXPLORATORY DEVELOPMENT EFFORTS IN PRESSURE SUIT
TECHNOLOGY

by

Major Erwin R. Archibald

6570th Aerospace Medical Research Laboratories
Wright-Patterson Air Force Base, Ohio

I. INTRODUCTION

The purpose of this report is to review some fundamental considerations that apply to the design of full pressure suits. The main characteristics of major types of pressure suit joints will be briefly considered. In addition, several current development efforts being sponsored or conducted by the United States Air Force, Aerospace Medical Research Laboratories at Wright-Patterson Air Force Base, Ohio, will be described.

The biomedical requirements that pressure suits must satisfy are well known and will only be mentioned briefly. These requirements include adequate oxygen, removal of carbon dioxide, and maintaining a physiologically acceptable thermal environment. To these must be added some means of protection from electromagnetic radiation and voice communication capability. In a space suit to be used for extravehicular activity, some additional shielding from micrometeoroids seems desirable. Simply providing protection from the hostile environmental hazards is not an inherently difficult problem. However, if we accept the premise that after having been given all this protection, the crewman must still be able to move reasonably normally and use his body to perform useful work, therein lies the crux of the problem. In general, every bit of added protection built into a pressure suit costs something in the way of mobility, or ability to perform useful work. This is shown graphically in Fig. 1.

A. Historical Background

Although Paul Bert was well aware of the use of diving suits at greater than sea level pressure, Haldana, in 1920, was apparently the first to suggest the use of pressure

suits to provide physiological protection at altitudes above 40,000 ft (18). Sir Robert H. Davis of London designed the first high altitude pressure suit for the American balloonist Mark Ridge, who wore it in a successful low pressure chamber test to 84,000 ft on 29 November 1933. Wiley Post completed several high altitude flights in the fall of 1934, wearing a full pressure suit built for him by the B. F. Goodrich Company. The Haldane-Davis stratosphere flying suit was further developed by the Air Ministry of the United Kingdom, and flights were made to about 50,000 ft by Squadron Leader Swain in September 1936, and to 54,000 ft by Flight Lieutenant Adam in June 1937. High altitude full pressure suits were also built during the period from 1935 to 1938 by the French, Germans, Italians, Russians, and Spanish (18). These early full pressure suits were the direct ancestors of today's highly sophisticated space suits. Full pressure suits apply pneumatic pressure directly to all parts of the wearer's body. Those being actively developed at present may be classified as hard suits or soft suits. A hard suit is one which is rigid when unpressurized, for example, the Litton Space Sciences Laboratories RX suit shown in Fig. 2. A soft suit is one which is flexible when not pressurized, for example, the United States Air Force AP 22/S-2 suit shown in Fig. 3. Partial pressure suits pressurize the wearer's body indirectly. An example of one of the most successful partial pressure suits is the French E.F.A. Type 30 Stratosphere Suit shown in Fig. 4.

II. FUNDAMENTAL CONSIDERATIONS

A. Flexible Membrane Theory

From the theory of flexible membranes, it follows that a flexible container, when pressurized above ambient, will assume a circular cross section, unless it is forcibly prevented from doing so, i.e., restrained. Although portions of the human anatomy are reasonably circular in cross section (such as the arms and legs), other portions are not (e.g., the torso); Fig. 5 illustrates the point. This fundamental fact concerning the behavior of flexible membranes leads to "ballooning," or soft suit "growth" when pressurized, and the necessity for internal or external restraints, such as helmet tie-down devices.

B. Mobility

Although there is no precise definition of the term, the word mobility is widely used to describe relative ease of motion in a pressure suit. Mobility includes several

components, for example, torque or bending moment, angle of excursion or degree of flexion and extension, and velocity of movement. While it is a generally useful descriptive term, statements concerning mobility of pressure suits are of much more value if they include reference to a specific joint, angle of excursion, and representative torque values.

1. Bending Moments

Bending an inflated flexible cylinder requires energy. Deformation of the cylinder, in turn, increases the surface energy of the material, setting up a constant force that tends to restore the material to its original configuration. The man inside the suit must expend energy to deform the material from its point of minimum surface energy, and must continue to exert force to prevent return to its neutral point. In addition, in a long pressurized cylinder, such as an arm or leg segment, considerable force is being exerted on the ends, which tends to keep the member extended in a straight line. This requires some type of axial restraint, in addition to the required circumferential restraint. Stein and Hedgepeth investigated the physical characteristics of partially wrinkled membranous cylinders (13). They found that a bending moment of 11 lb-ft (1.52 Kg-m) was required to bend an unrestrained membranous cylinder to a 90° angle. This cylinder was 5 in. in diameter, pressurized to 3.0 psi (155 mm Hg). This is in good agreement with the theoretical bending moment, 13 lb-ft, for a 5 in. cylinder pressurized to 3.5 psi; calculated from the following relationship:

$$(1) M = 0.9\pi r^3 p$$

where M = Bending Moment

r = Radius of Cylinder

P = Gauge Pressure

Since the bending moment of a cylinder varies directly with the radius to the third power, it follows that for the best mobility, the pressure suit should fit as intimately as possible. It also follows that pressure suits which have a load bearing flexible surface will invariably have high bending moments in their joints. Included in this category are suits of link net and capstan construction, as well as various bladder type partial pressure suits.

2. PdV Work

Whenever the flexure of a pressure suit joint results in a decrease in volume, as occurs for example in bending the arm or leg, energy is required to compress the gas. Energy is also required to hold the pressure suit joint in a flexed position. This effect is similar and additive to the energy requirement previously described for bending a membranous cylinder. PdV work is defined by the following expression:

$$(2) W = \int_{V_1}^{V_2} P dV \text{ where } P_1 \text{ increases to some value } P_2$$

and W = Work of compressing the gas in the suit

P = Pressure of gas in the suit

V = Volume of gas in the suit

3. Friction

Friction resulting from the movement of cables, pulleys, straps, and other restraint devices further reduces the mobility of pressure suits. In link net suits, friction is a major factor which limits mobility since any bodily movement causes the gas containing bladder to drag across the restraining layer of cords.

III. BASIC TYPES OF FULL PRESSURE SUIT JOINTS

While there are a few minor variations that do not fit the scheme, nearly all existing full pressure suit joints fall into one of the four following general types:

1. Link Net.
2. Axially Restrained Convoluters.
3. Constant Volume Rolling Convoluters.
4. "Stovepipe" Rotating Segments.

These four basic types of joints will now be briefly considered.

A. Link Net

Probably the most familiar type of full pressure suit

restraint and joint construction is the link net system shown schematically in Fig. 6. Basically there are two layers, the innermost oversize gas tight membrane, and a net garment that restrains the gas bag when the suit is pressurized. Movement of a link net joint is hampered by friction between the restraining network of cords and the underlying membrane, which tends to bulge out through the openings in the restraint layer. The torque characteristics of link net joints are in close agreement with theoretical values derived from membrane theory. This type of construction is inherently of lighter weight than most others, and therefore advantageous in a full pressure suit intended for emergency use in high altitude aircraft operations. However, for an extravehicular suit under zero gravity conditions, this advantage disappears and the inherently high bending moments become unacceptable if the crewman attempts to perform any useful work.

B. Axially Restrained Convolutcs

A comprehensive discussion of bellows theory is beyond the scope of this paper. In 1961 the International Latex Company performed a detailed study of bellows behavior and theory (7). More recently the theory was reviewed and extended by Richardson and his collaborators (11). Fig. 7 shows two typical configurations of bellows joints, a single axis bellows, which might be used for the knee or elbow joint, and a two axis bellows which could be used in a shoulder joint. In general, bellows joints require both axial and circumferential restraint. To minimize bending torque the bellows joint should be composed of as many individual convolutes as possible so that each need only be deflected a small amount. In theory it is possible to achieve nearly constant volume bellows but in practice there is almost always some change in volume with flexion and extension of molded bellows.

C. Rolling Convolute

This type of joint is shown in Fig. 8. It is a true constant volume joint that consists of flexible membranes and rigid restraining segments articulated through an intricate system of gimbals or Cardanic links (14, 15). This type of joint has been developed primarily by Litton Systems, Inc. To date it has been used successfully in hard suits only. Bending torques of this type joint are the lowest of any full pressure suit in being at present and this principle appears to have great promise for use in extravehicular or lunar surface pressure suits. Resistance to bending a joint

of this type arises from second order factors, such as friction in the Cardanic links.

D. "Stovepipe" Rotatable Segments

The "stovepipe" concept is shown schematically in Fig. 9. This is also a true constant volume joint. Flexion or extension of a joint is achieved through rotation of "pie" shaped segments. Resistance to bending arises from friction in the rotating gas seals. Early estimates of bending torque of this type joint placed the value about equal to that of the constant volume rolling convolute (11). However, more recent measurements of actual prototype joints show much more favorable torque values, about an order of magnitude lower than predicted. The most active effort to develop this concept is being conducted by Vykukal at the NASA (National Aeronautics and Space Administration)-AMES Research Center in California.

E. Comparison of Typical Pressure Suit Joints

Pressure suit testing is still in its infancy and objective, quantitative, comparative test data on the various pressure suits are scarce. In 1965, Parry *et al* of the Hamilton Standard Division of United Aircraft Corp. completed a thorough study of available equipment and methods for pressure suit testing (10). They recommended a massive assault on this problem, utilizing an integrated group effort with the participation of flight medical officers, physiologists, mechanical engineers, and experts from other disciplines. This recommended approach would have used sophisticated hardware for measuring the comparative metabolic costs of wearing various pressure suits in a variety of work situations and would have utilized a power, programmed, anthropomorphic dummy with off-line computer links for precise measurements of pressure suit dynamics. At present, mobility testing of pressure suits is largely subjective, heavily dependent on skilled pressure suit subjects. Although more quantitative methods for pressure suit testing are solely needed, skilled pressure suit subjects will be an integral part of any test procedure for the foreseeable future. TABLE I shows typical bending moments for several different pressure suit joints.

With regard to the data in TABLE I it should be noted that while bending torques of the hard joints are, in general, lower than the torque values for soft joints, it is possible to perform certain emergency maneuvers in a soft suit that cannot be done in a hard suit. This is because

the hard suit joints must always have finite limits to their excursion, while the design limits of soft suit joint excursion can be exceeded by using brute force. It is also to be noted that torque values of hard joints do not vary with pressure in the 2-5 psi range.

TABLE I. BENDING TORQUES FOR PRESSURIZED JOINTS. ALL JOINTS FIVE INCHES IN DIAMETER, PRESSURIZED TO 3.5 PSI.

<u>Type of Joint</u>	<u>Torque (lb-ft)</u>	<u>Remarks</u>
Cylindrical Membrane (theoretical)	13.0	90° Deflection
*Bellows	1.2	0-90° Deflection
**Rolling Convolute	0.4-0.65 (estimated)	0-140° Deflection 2-5 psi
***Stovepipe	1.5 (estimated)	Torque linear throughout range. Estimated high starting torque.

*Durney and Redden, 1961, (5).

**Litton Systems, Inc., 1965.

***Richardson, 1967, (11).

F. Typical Construction of Soft Space Suits

Fig. 10 shows a schematic representation of a composite soft space suit, illustrating various types of soft pressure suit joints and restraints. With particular reference to the thermal underwear shown in the diagram, cooling is achieved by circulating water through a series of tubes, in contact with the crewman's skin. There are ample data to show that cooling the man by means of air is impracticable and that a water cooled garment is a much better solution (1, 2, 9, 12, 16, 17). This is particularly true of a space suit for extravehicular or lunar surface use where the crewman will generate heat loads on the order of 3000 BTU/hr. Water cooled undergarments may also find application in other adverse thermal environments (6, 8). Some protection from micrometeoroids is considered necessary in soft space suits. This is achieved by adding multilayer overgarments to the basic suit, as shown schematically in the diagram. This inevitably results in some additional loss of mobility. Hard suits inherently provide greater

protection from micrometeoroids and do not require any additional overgarments.

IV. CURRENT DEVELOPMENT EFFORTS

Two current pressure suit development efforts will now be briefly described.

A. The Boyle's Law Pressure Suit

This is a passively pressurized, intravehicular, partial pressure suit that operates on the well known principle of Boyle's Ideal Gas Law. In appearance and comfort, the suit is comparable to a standard flying coverall. Pressurization is achieved by the passive expansion of gas contained in flexible sealed tubes attached to the inner surface of the suit. The concept originated with Boyle, Ritzinger, and Davis at the USAF School of Aerospace Medicine, where the initial feasibility demonstration suits were built (3, 4). Fig. 11 shows Major Davis wearing the suit at ground level. The suit shown is a developmental model built by Uniroyal. The present development work is being performed by Uniroyal, under the technical direction of the Aerospace Medical Research Laboratories, with the full participation of Major Jefferson Davis of the USAF School of Aerospace Medicine. Fig. 12 shows the passive pressurization tubes attached to the inside surface of the coverall with tapes. Fig. 13 shows the same suit and subject in an altitude chamber test at 80,000 ft altitude. To date this particular suit has been worn by four different subjects in 52 low pressure chamber tests ranging from 60,000 to 85,000 ft and for periods up to 60 min at 80,000 ft. Pressurized mobility is comparable to the MC series capstan suits. One advantage of the Boyle's Law Suit is that it requires no connection to ship's supply for suit pressurization or ventilation gas. We believe the suit will provide emergency protection even if several of the tubes are penetrated. The suit does not have to be as closely fitted as the MC- capstan suits. It is much more comfortable in the unpressurized mode than any other pressure suit, which should lead to better acceptance by aircrewmembers. The suit shown weighs 5 lbs, 6 oz. The suit provides good water flotation due to the residual gas contained in the tubes even at sea level. Fig. 14 shows the time course of the subject's skin temperatures and pressures during a 10 min chamber test at 65,000 ft and -30C ambient temperature. While no measurements were made of the gas temperature within the sealed tubes, it is apparent that heat transfer from the subject keeps the gas from getting too cold for adequate emergency pressurization, and

that this effect shows a more or less progressive increase after the fifth minute of the 10 min test period. The Boyle's Law Suit obviously has a potential application as a constant-wear intravehicular suit for prolonged space flight.

B. Second Generation Hybrid Extravehicular Space Suit

In June of 1965 the Aerospace Medical Research Laboratories sponsored a one year study effort to define the state-of-the-art in pressure suit technology (11). The study was performed by Arthur D. Little, Inc. with D. L. Richardson as the principal investigator. Fig. 15, which is one result of this study, shows the preliminary design concept for a second generation extravehicular space suit for use on or near the surface of a space station in a 300 nautical mile earth orbit. I call this proposed suit a hybrid, because it is partly hard and partly soft. The essential features of this suit include a hard torso, with completely integrated life support system (hence no umbilicals), hard suit construction for shoulder, elbow, and waist joints, and soft suit construction below the waist. The life support system is rechargeable while the crewman is outside the parent vehicle. An automatic system for emergency sealing and pressurization is provided. Thermal balance is achieved by completely insulating the crewman and rejecting body heat by the evaporation of water and using a circulating water cooled undergarment. The suit is intended solely for EV (extravehicular) use and the design is based on the assumption that no pressure suit will be needed inside the space station. The chief design goal was to increase the crewman's capability to perform useful work in earth orbital space and at the same time to provide maximum protection from the hostile space environment. This conceptual design is presently being studied and defined in detail. It is anticipated that a feasibility demonstration model of the hybrid EV space suit will be built in 1969, using state-of-the-art components wherever they can be used. Detailed design and integration studies are presently underway at the Hamilton Standard Division of United Aircraft Corp. Fig. 16 shows an artist's concept of one possible configuration, in which the propulsion system has been integrated into the hard torso.

V. SUMMARY

The fundamental problem in pressure suits is that they limit the wearer's capacity to perform useful work. In addition, certain other physiological problems are always potentially present since the pressure suit must provide adequate oxygen, removal of carbon dioxide, and thermal balance. As

extended extravehicular activity becomes a reality, great increases are required in mobility of full pressure suits. Fundamental considerations were briefly reviewed. The problem of finding ways to increase the mobility of soft pressure suits is further complicated by the necessity to provide protection from thermal extremes, electromagnetic radiation and micrometeoroid particles. These three classes of environmental hazards are either unique features of the space environment or else the problem is orders of magnitude greater in the space environment as compared to customary flight altitudes. Most methods of providing the additional protection required in the space environment, must of necessity further decrease pressure suit mobility. Advantages and disadvantages of the four primary types of pressure suit joints were briefly considered. Results of current development efforts on the Boyle's Law pressure suit were described. Research and development efforts leading to conceptual design of a hybrid second generation space suit were reviewed.

VI. REFERENCES

1. Bowen, J. D., and R. F. Witte. Thermal Transport System for a Space Worker's Garment. AMRL Memo M-49, Aerospace Medical Research Laboratories, Wright-Patterson Air Force Base, Ohio. August 1963.
2. Burton, D. R., and L. Collier. The Development of Water Conditioned Suits. TN-Mech-Eng-400, Royal Aircraft Establishment, Farnborough, England. April 1964.
3. Davis, J. C., J. Boyle III, and F. R. Ritzinger. Preliminary Studies on a New Partial-Pressure Suit Concept. SAM-TR-67-15. United States Air Force School of Aerospace Medicine, Brooks Air Force Base, Texas. February 1967.
4. Davis, J. C., F. R. Ritzinger, and L. E. Noble. Studies on an Advanced Passively Pressurizing Partial Pressure Suit. Preprints of Scientific Program, pp. 286-287, Aerospace Medical Association, Wash., D. C. 1967.
5. Durney, G. P., and R. J. Redden. Range of Movements and Torque Measurements for Full Pressure Suit. International Latex Corp., Industrial Products Div., Report No. SPD-X-2161. 1961.
6. Hatlelid, C. M., J. E. Armstrong, and C. E. Harris. Flight Evaluation of Simple Liquid Transport Cooling System for Aircrewmembers. Preprints of Scientific Program, pp. 121-122, Aerospace Medical Association, Wash., D. C. 1967.
7. International Latex Co., Full Pressure Suit Research and Development. ASD Technical Report 61-588, Aerospace Medical Laboratory, Wright-Patterson Air Force Base, Ohio. October 1961.
8. Kaufman, W. C., and J. C. Pittman. A Simple Liquid Transport Cooling System for Aircrewmembers. AMRL-TR-66-48. Aerospace Medical Research Laboratories, Wright-Patterson AFB, Ohio. 1966.
9. Mazy, R. S., T. E. Mattingly, J. W. Felder, Jr., and C. F. Lombard. Development of an Internal Restraint System for an Integrated Restraint-Pressure Suit System. NASA CR-718, National Aeronautics and Space Administration, Wash., D. C. 1967.

10. Parry, D. G., L. R. Curry, Jr., D. B. Hanson, and G. B. Towle. A Study of Techniques and Equipment for the Evaluation of Extravehicular Protective Garments. AMRL-TR-66-4, Aerospace Medical Research Laboratories, Wright-Patterson AFB, Ohio. February 1966.
11. Richardson, D. L. Research to Advance Extravehicular Protective Technology. AMRL TDR 66-250, Aerospace Medical Research Laboratories, Wright-Patterson AFB, Ohio. 1967.
12. Roth, E. M. Bioenergetics of Space Suits for Lunar Exploration. NASA SP-84, National Aeronautics and Space Administration, Wash., D. C. 1966.
13. Stein, M., and J. M. Hedgepeth. Analysis of Partly Wrinkled Membranes. NASA TN D-813, National Aeronautics and Space Administration, Wash., D. C. July 1961.
- 13a. Streimer, I., D. P. W. Turner, C. A. Tardiff, and T. L. Stephens. An Investigation of the Effects of Pressure Suit Wearing on Work Output Characteristics. Aerospace Medicine 35: 747-751. 1964.
14. Sullivan, A. F. Functional Man in Simulated Space. Publication No. 4370, Paper No. 12, Litton Systems Inc., Beverly Hills, California. 1965.
15. Sullivan, A. F. Chamber Compatible Suit Development. Proceedings of the Seventh Annual Symposium on Space Environment Simulation, The Boeing Co., Seattle, Wash. 1966.
16. Veghte, J. H. Efficacy of Pressure Suit Cooling Systems in Hot Environments. Aerospace Medicine 36: 964-967. 1965.
17. Webb, P., and J. A. Annis. Bio-Thermal Responses to Varied Work Programs in Men Kept Thermally Neutral by Water Cooled Clothing. NASA CR-739, National Aeronautics and Space Administration, Wash., D. C. 1967.
18. Wilson, C. L. Physiological Protection of the CSU-4/P High-Altitude Pressure Suit. AMRL-TDR-62-112, Aerospace Medical Research Laboratories, Wright-Patterson AFB, Ohio. 1962.
19. Sections II and III of this report make extensive use of recent report by D. L. Richardson of A. D. Little, Inc., Cambridge, Mass. (11).

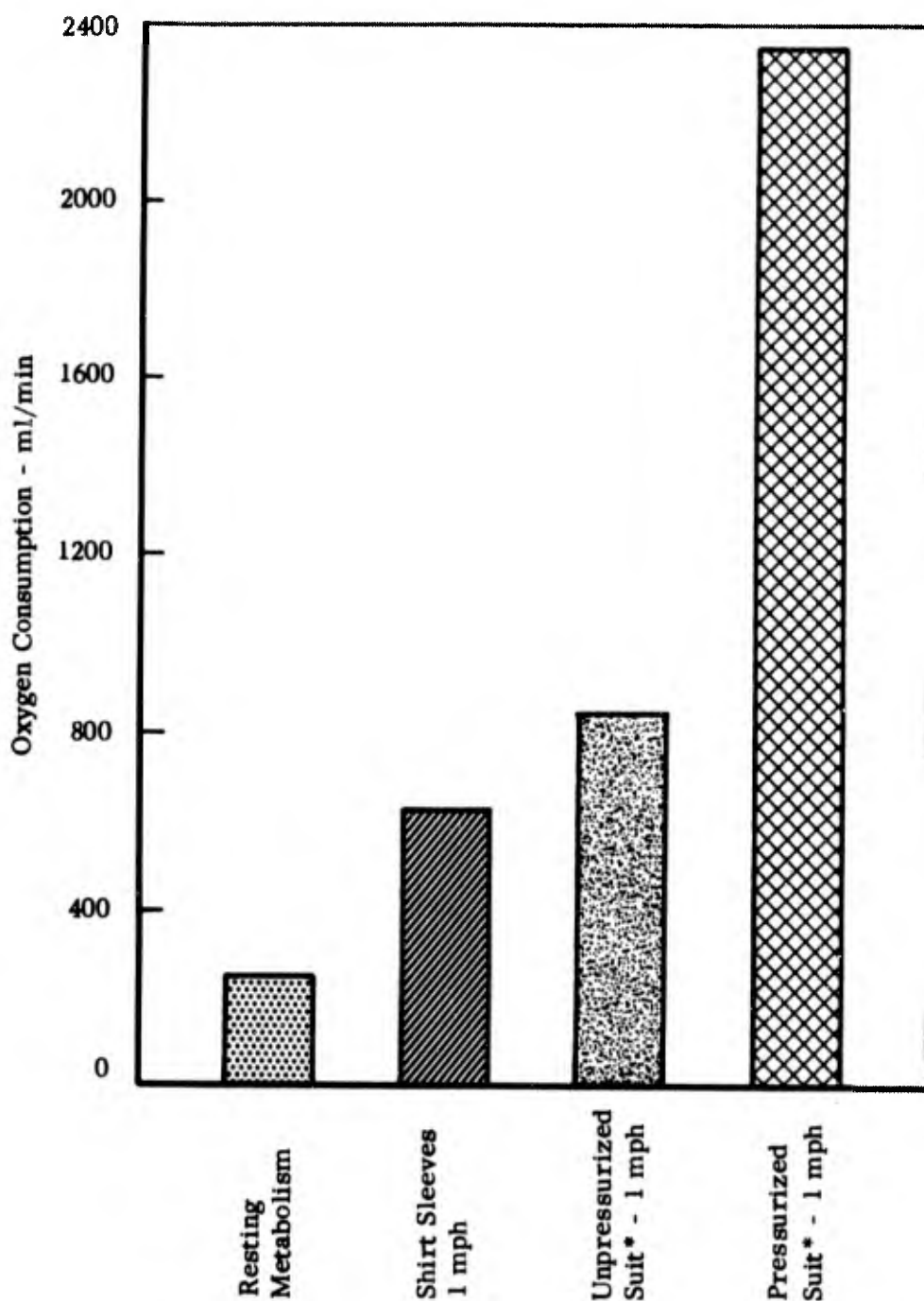

*Mean values for three suits.

Fig. 1 These data show a four-fold increase in oxygen consumption for mild exercise in a pressurized suit, as compared to the same exercise in shirt sleeves. The exercise consisted of walking on a treadmill at one mph. Data source: Streimer, et al (13a)

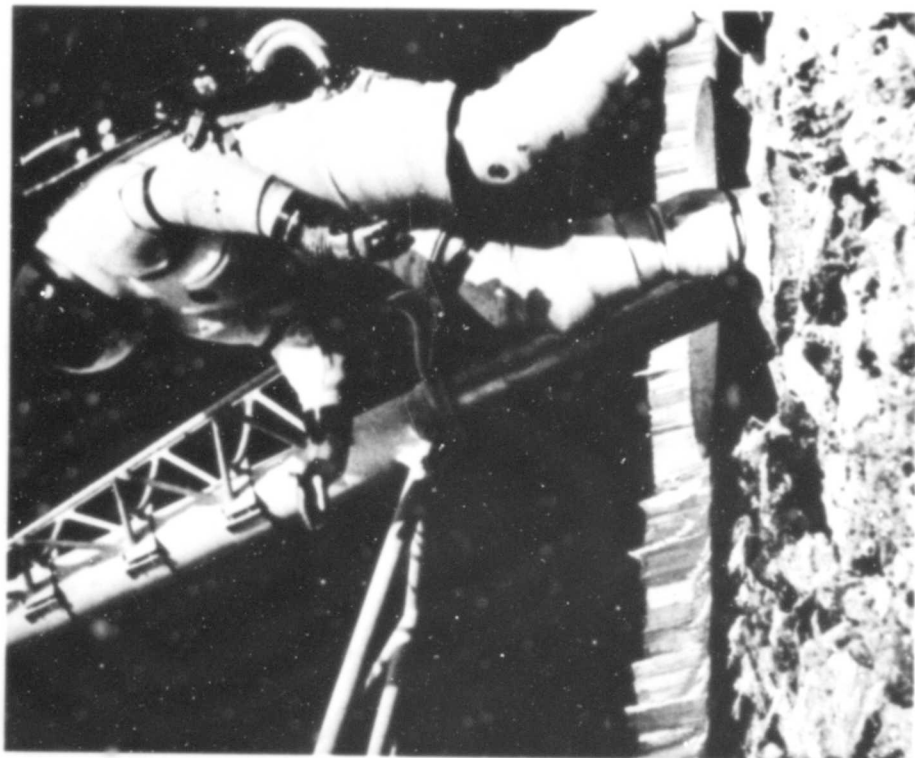

Fig. 2 An example of a hard pressure suit is the
Litton Space Sciences Laboratories
RX suit



Fig. 3 An example of a soft pressure suit is the
United States Air Force's AP 22/S-2 suit

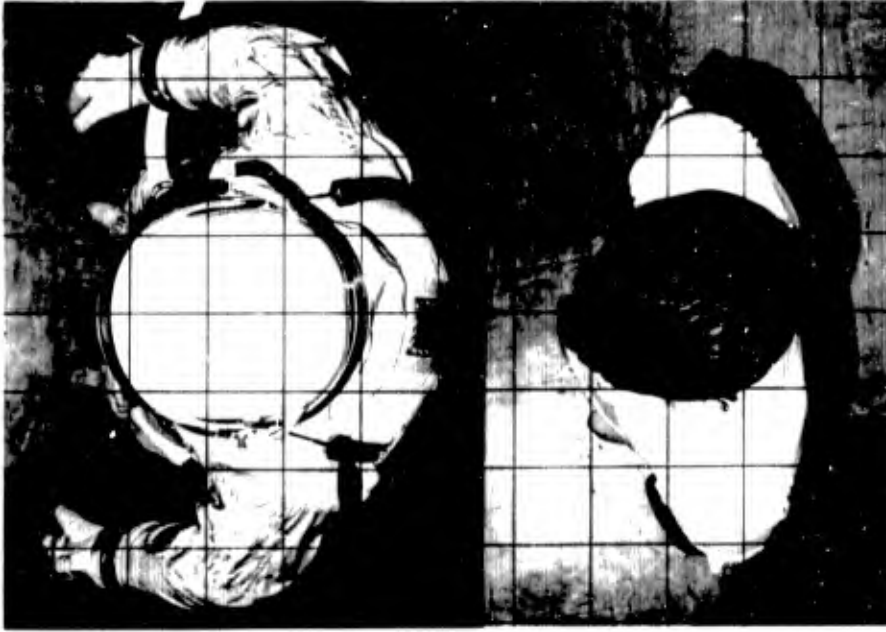

Fig. 5 Subject in shirt sleeves and wearing a pressurized G-4C soft pressure suit, as viewed from a point directly overhead; illustrating the fundamental tendency of pressurized flexible containers to assume a circular cross section

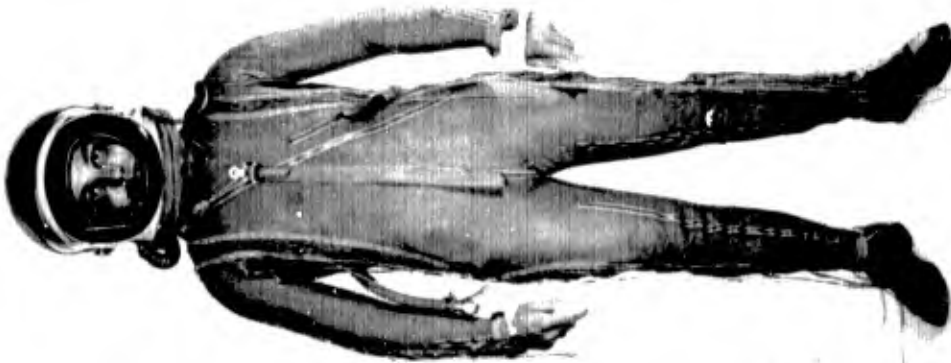

Fig. 4 The French E.F.A. Type 30 Stratosphere Suit is an example of one of the most successful partial pressure suits

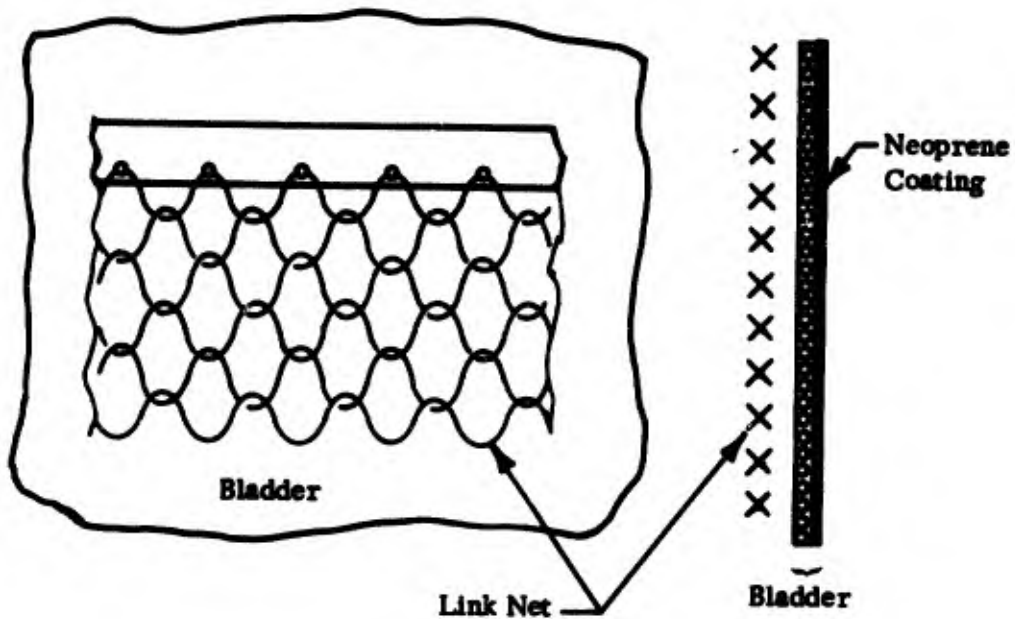
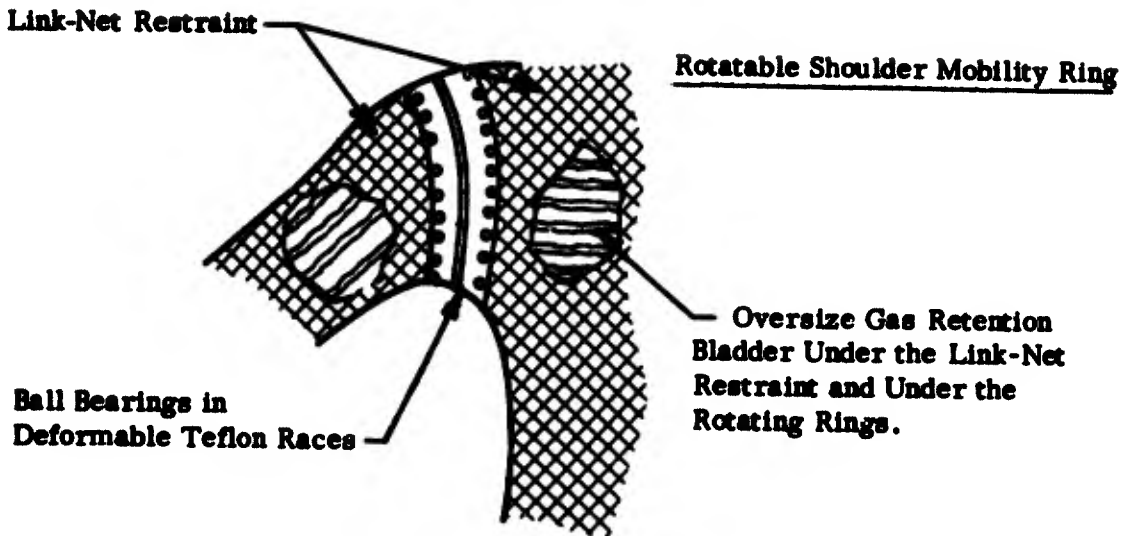
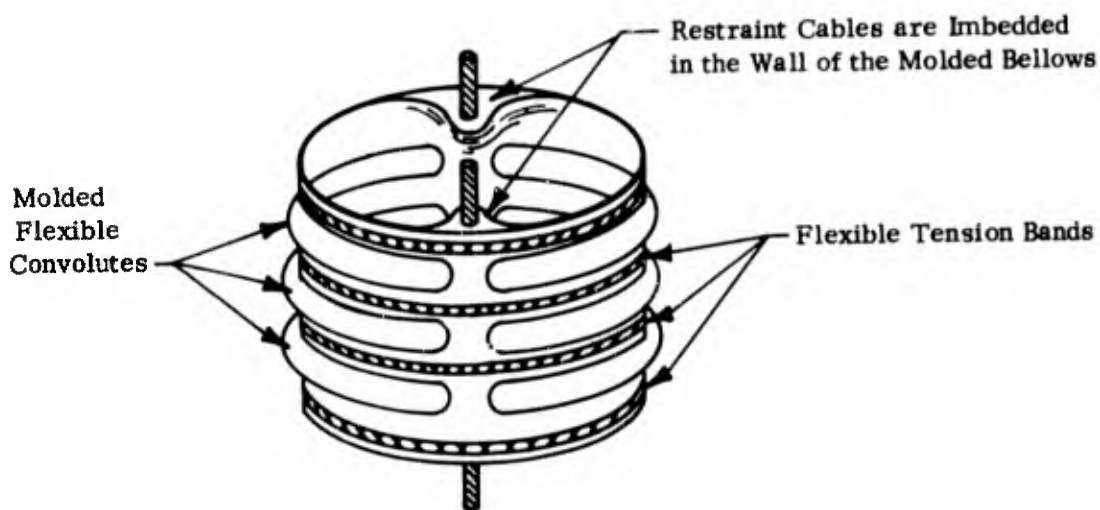
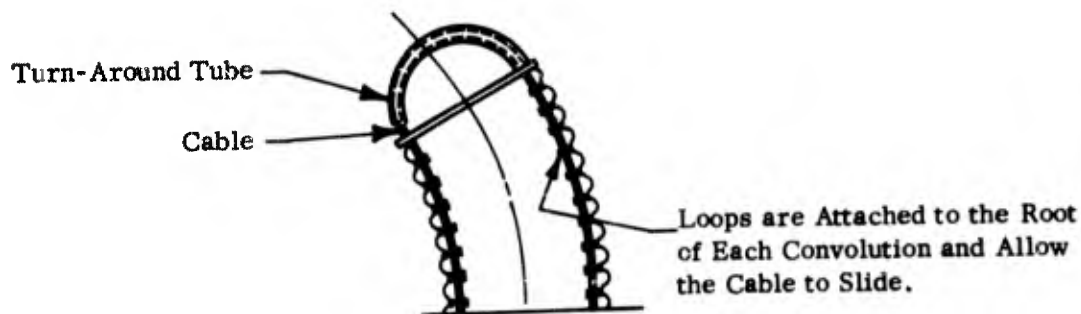

Fig.6 Basically, the link net suit consists of two layers, an inner oversize membrane and an outer network of looped cords that restrain the gas bag when it is pressurized



A. Monoplanar Molded Bellows



B. Two Degrees of Freedom Bellows

Fig. 7 Schematic diagram of two types of molded bellows joints; A. shows circumferential and axial restraint of a single axis bellows; B. shows one method of achieving two axis movement

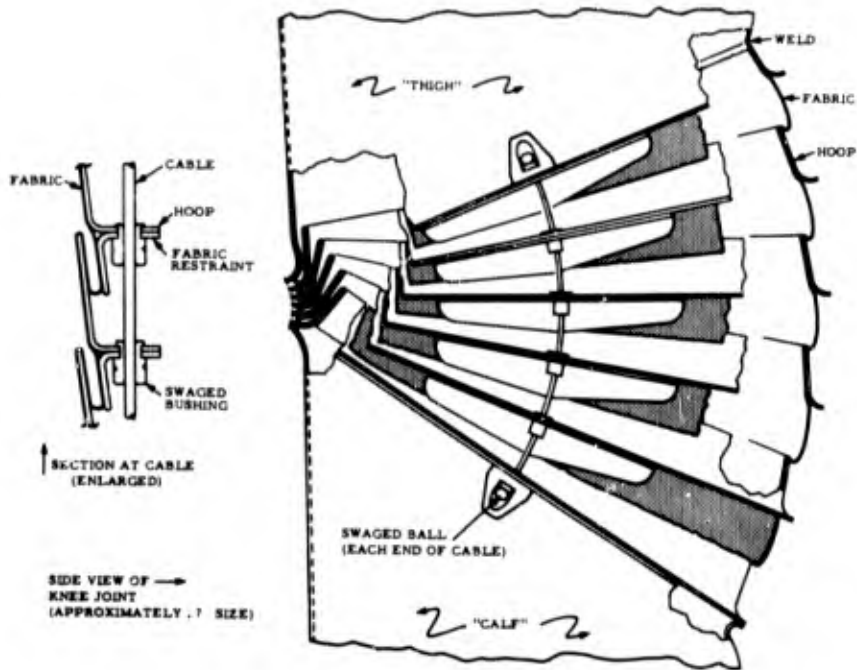

Fig. 8 A typical rolling convolute joint. During flexion and extension the increase in volume on one side is exactly counterbalanced by a decrease in volume on the other side

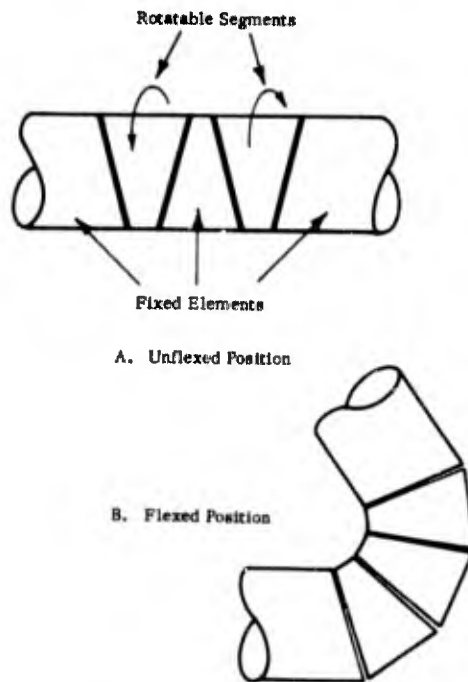

Fig. 9 "Stovepipe" rotatable segments, a type of hard pressure suit joint that uses rotatable gas seals. A, extended, B, flexed

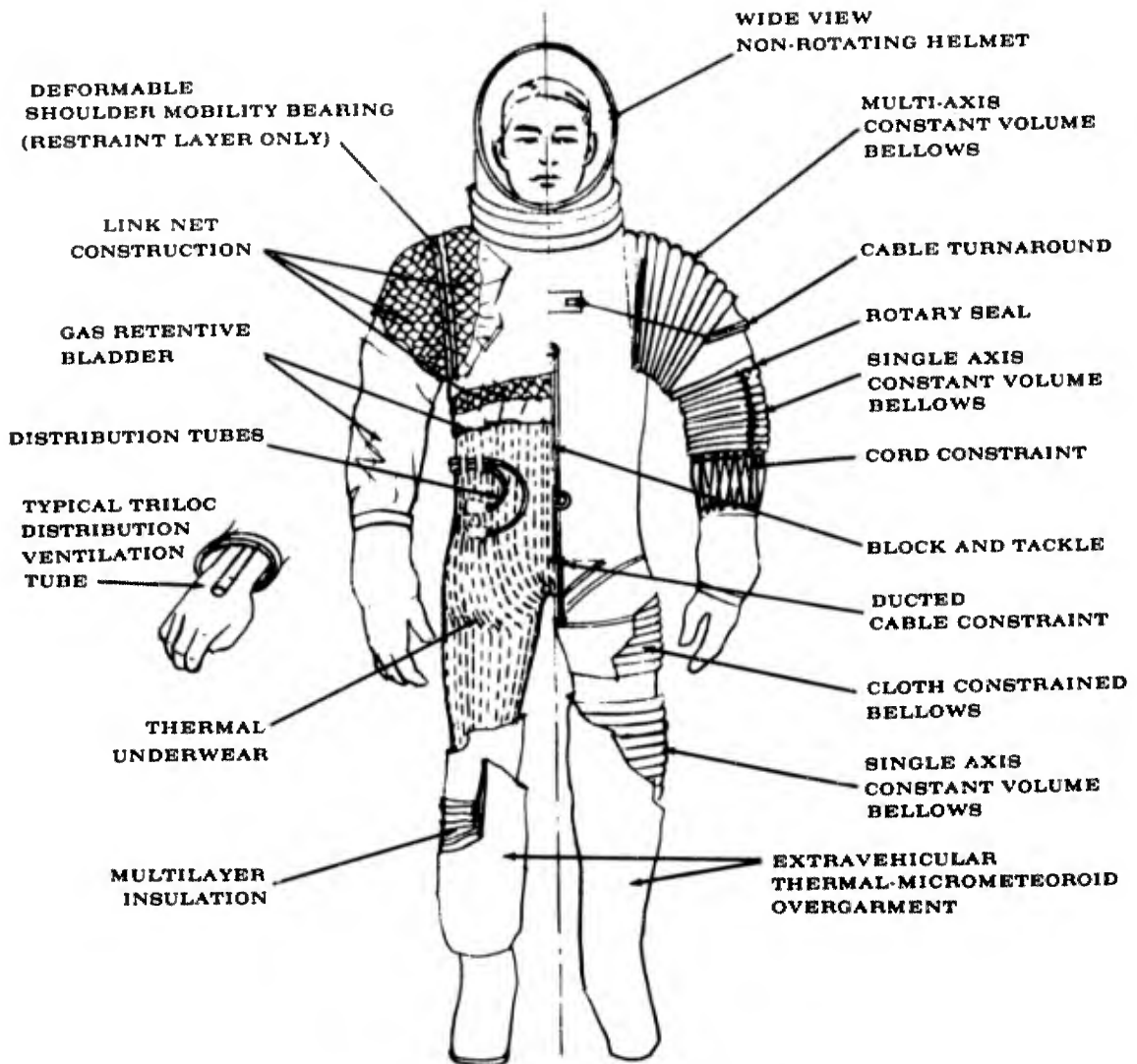

Fig. 10 Schematic representation of present state-of-the art soft pressure suits showing features of various types of pressure suits (11)

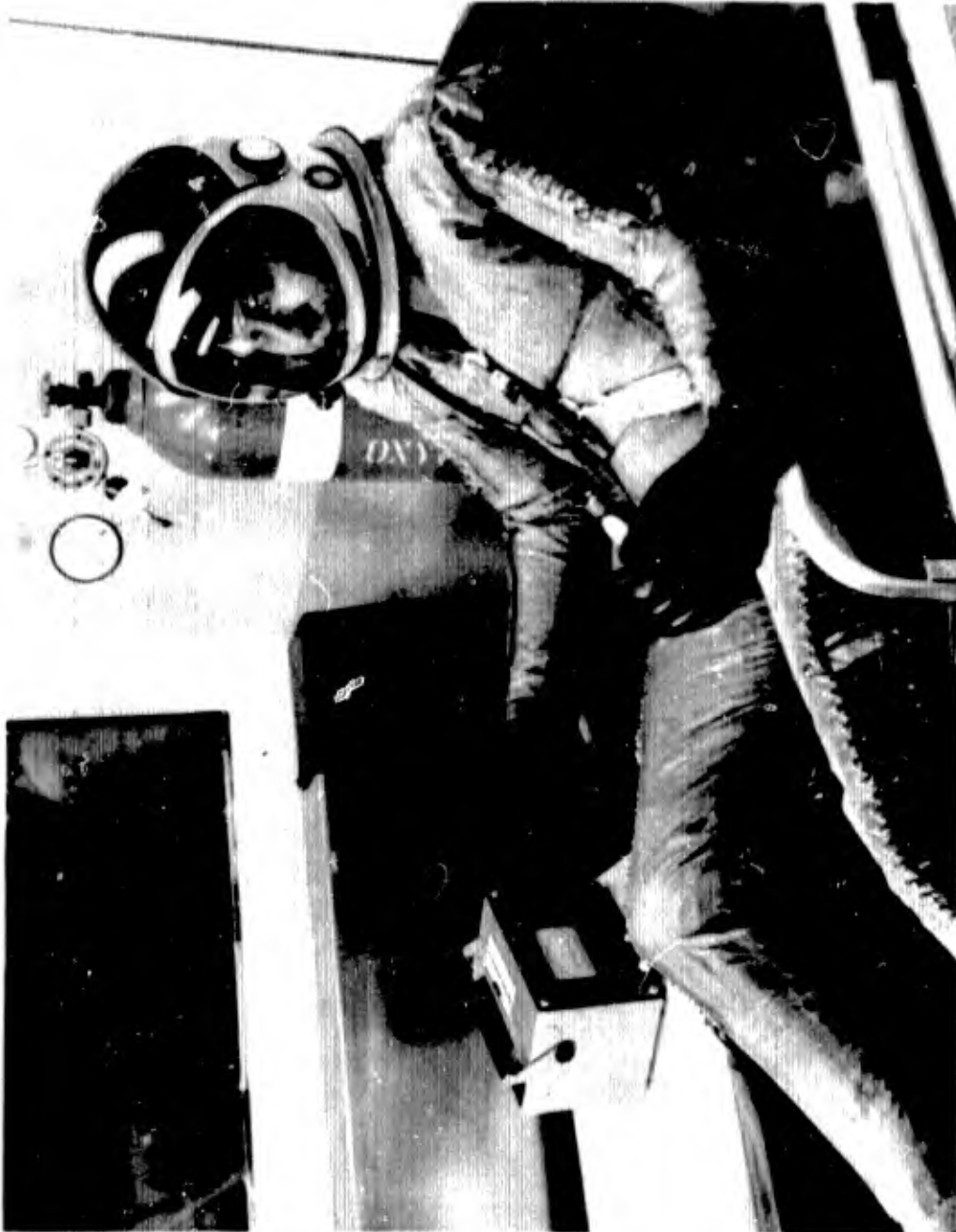

Fig. 11 The "Boyle's Law" partial pressure suit. This developmental model was built by Uniroyal. The suit is shown at ground level. The suit subject is Major Jefferson Davis, co-inventor with Boyle and Ritzinger (3, 4)



Fig. 12 This view shows the arrangement and method of attaching the sealed passive pressurization tubes in the torso of the "Boyle's Law" pressure suit

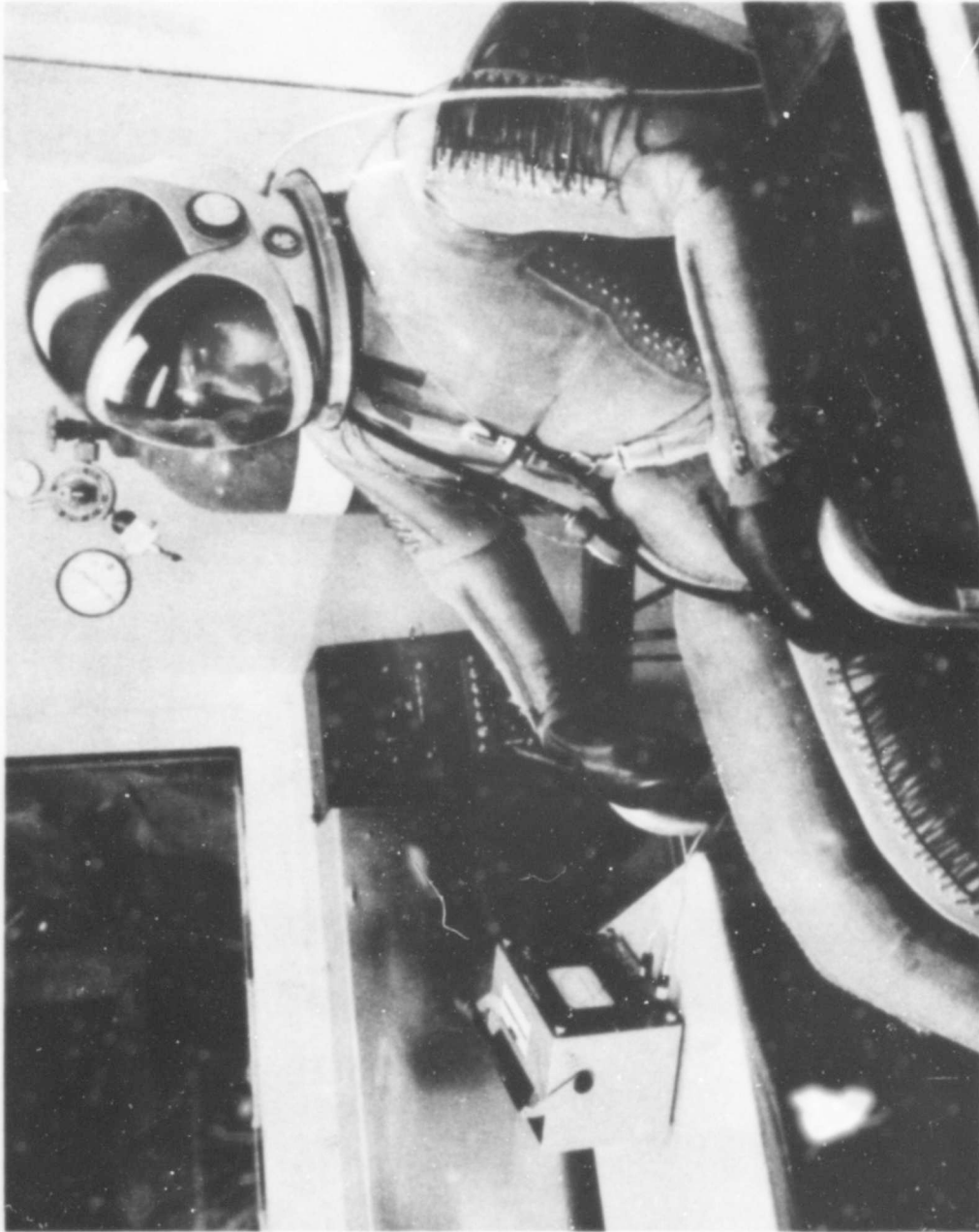

Fig. 13 The "Boyle's Law" partial pressure suit and subject in an altitude chamber test at 80,000 ft. The subject's hands were protected by partial pressure suit gloves with the pressurization tubes sealed off

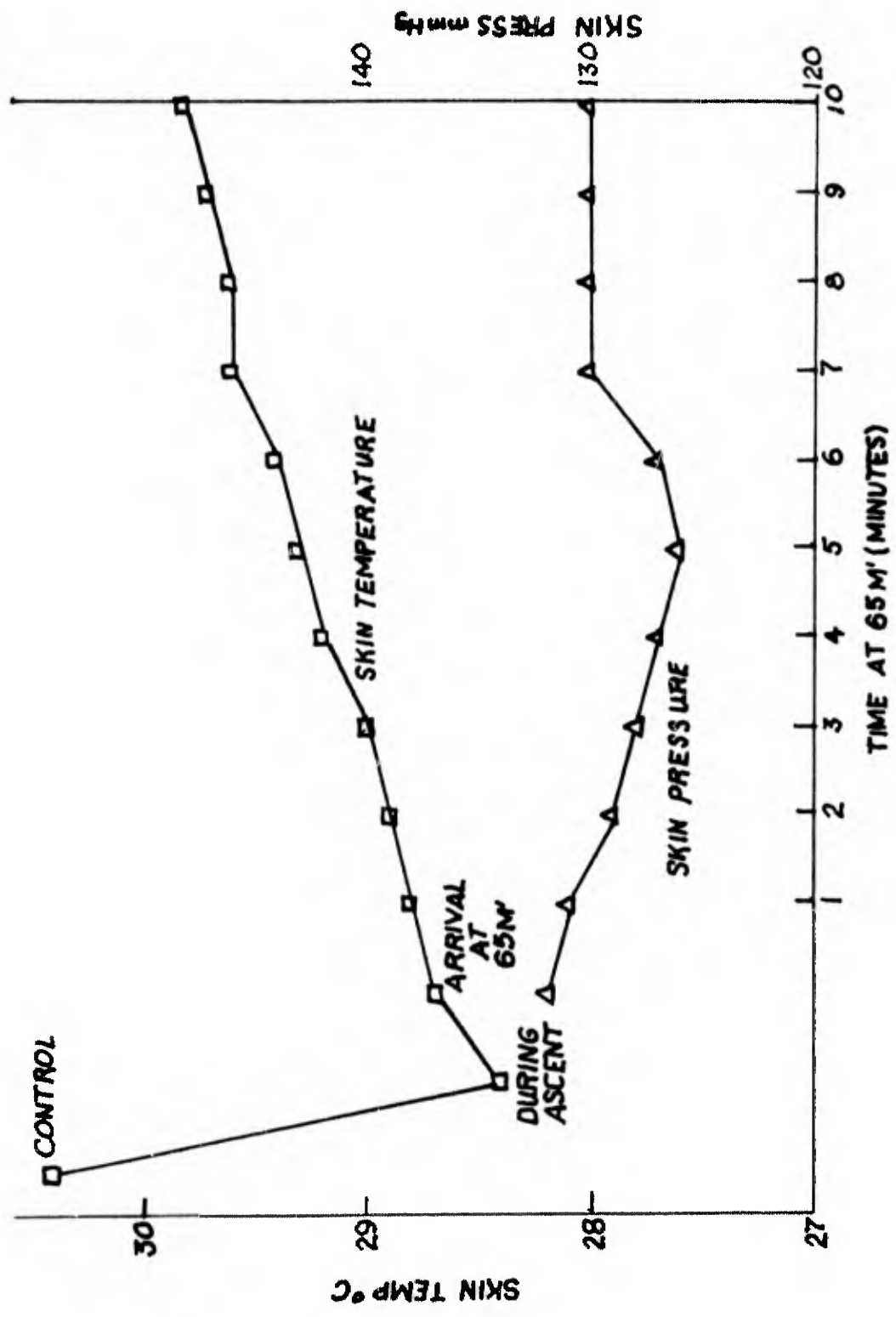
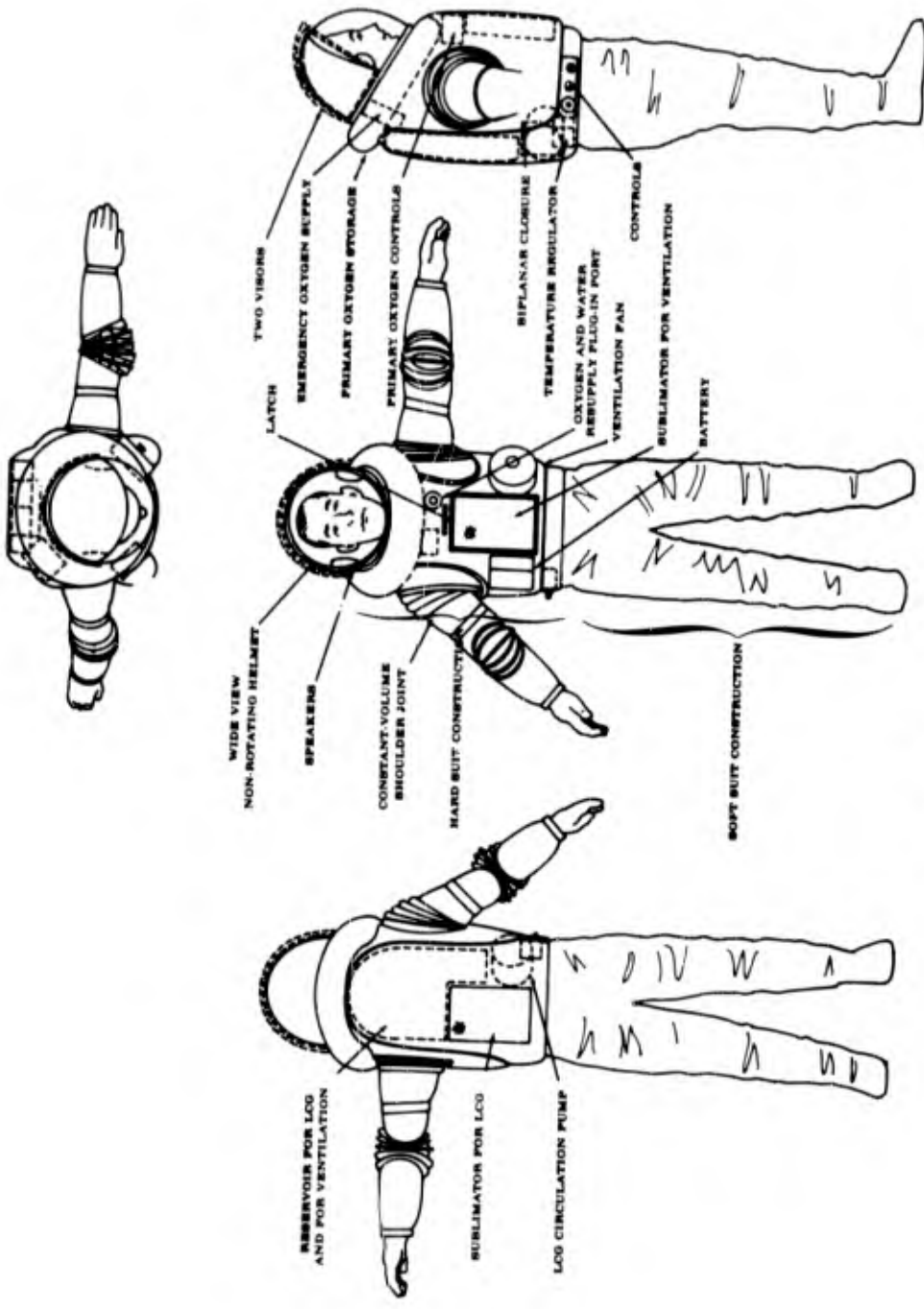

Fig. 14 Subject's skin temperature and pressure during a 10 min test of the "Boyle's Law" suit at 65,000 ft and -30C



COMBINED HARD AND SOFT SUIT WITH INTEGRATED LIFE SUPPORT SUBSYSTEM

Fig. 15 Conceptual design of a proposed second generation hybrid EV space suit

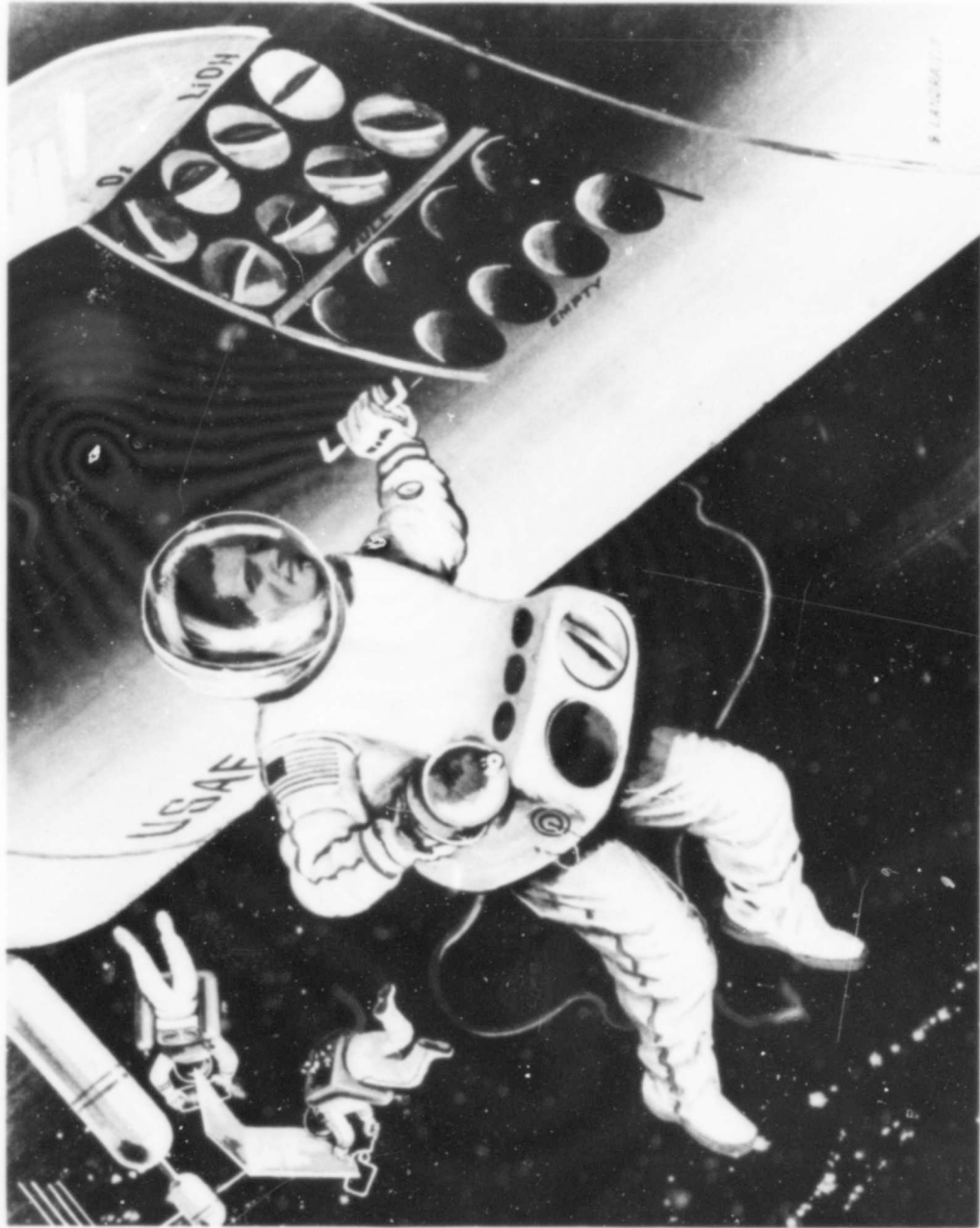

Fig. 16 Artist's concept of one possible configuration of the hybrid extravehicular space suit. This model has soft arm and leg sections and the propulsion system is integrated into the hard torso

BLANK PAGE

ETUDE DES VALEURS NORMALES DE LA CAPACITE VITALE ET
DU VOLUME EXPIRATOIRE MAXIMUM/SECONDE CHEZ LE
PERSONNEL NAVIGANT DE LA FORCE AERIENNE BELGE

par

Cdt Médecin J. Bande

Force Aérienne,
Centre de Médecine Aéronautique,
Boulevard Général Jacques,
Bruxelles 4

RESUME

=====

Après une brève description de la technique employée pour la détermination de la capacité vitale (CV) et de volume expiratoire maximum seconde (VEMS), les facteurs susceptibles de perturber les mesures sont analysés.

L'étude transversale des résultats obtenus dans une population de sujets normaux a permis l'élaboration pour les paramètres étudiés de formules de prédiction exponentielles et linéaires en fonction de la taille et de l'âge.

D'autre part, grâce à l'étude longitudinale des résultats obtenus au cours de cinq années consécutives, la loi CV en fonction de l'âge a été recherchée et les premiers résultats sont communiqués.

Les données d'un échantillon de sujets congolais ont également été comparées aux valeurs théoriques proposées, tandis que l'influence de l'habitude de fumer sur les paramètres ventilatoires a été recherchée.

La comparaison des résultats aux valeurs théoriques proposées dans la littérature des dernières années a révélé une excellente corrélation avec les normes de De Kroon .

En conclusion une nouvelle approche du problème est suggérée : interprétation des résultats initiaux par rapport aux valeurs théoriques obtenues par une formule de prédiction classique et pour les examens ultérieurs, calcul, pour chaque individu, des scores à obtenir en vertu de la loi, CV en fonction de l'âge, ce qui permettra une interprétation plus précise des valeurs observées.

ETUDE DES VALEURS NORMALES DE LA CAPACITE VITALE ET DU VOLUME
EXPIRATOIRE MAXIMUM/SECONDE CHEZ LE PERSONNEL
NAVIGANT DE LA FORCE AERIENNE BELGE

INTRODUCTION

En 1960 nous avons introduit des mesures spirométriques dans la batterie d'examens médicaux de sélection et de contrôle du personnel navigant de la Force Aérienne belge. Etant donné le temps dont nous disposions pour chaque examen nous nous sommes limités à la Capacité vitale (CV) et du volume expiratoire maximum/seconde (VEMS) comme mesures à effectuer de manière systématique.

Par CV nous entendons, selon Hutchinson (7), le plus grand volume qu'un individu peut expirer après une inspiration forcée. Le VEMS est, comme le définit Tiffeneau (10), le plus grand volume qui peut être expiré pendant la première seconde d'une expiration rapide faisant également suite à une inspiration maximale. Nous ferons également allusion, lors de cet exposé, à la capacité vitale forcée (FVC), mesure assez répandue dans les pays Anglo-saxons et qui est en somme une mesure de CV obtenue lorsque l'expiration rapide d'un VEMS est poursuivie jusqu'au moment où tout l'air est chassé des poumons (Figure 1).

Afin de pouvoir interpréter les valeurs obtenues, il faut les comparer à des valeurs théoriques et nous avons été confrontés avec le choix de celles-ci. En effet, de nombreuses formules de prédiction en fonction de la taille, de l'âge, de la surface corporelle, du métabolisme basal et d'autres paramètres, biologiques ont été proposées. En 1960 la formule selon Baldwin et coll. (2) était couramment utilisée en clinique. Toutefois, ayant été établie à partir d'un nombre de patients hospitalisés, ces valeurs ne convenaient pas pour l'étude de résultats obtenus chez des sujets normaux. Par contre, Jouasset (8) venait de présenter de nouvelles normes suite à une importante étude effectuée de 1955 à 1960 dans les pays de la communauté européenne du charbon et de l'acier (CECA) ; nous avons cru bien faire en les adoptant.

Cependant nous avons été frappés assez rapidement par certaines différences observées entre ces valeurs théoriques et les résultats obtenus chez des sujets pourtant bien motivés et en bonne santé. Nous avons décidé de réétudier le problème afin d'établir nos propres normes.

TECHNIQUE ET SUJETS EXAMINES

1. Technique.

La CV et le VEMS sont toujours mesurés en position assise dans un spiropgraphe Pulmotest Godart. Le sujet respire donc dans un circuit fermé et porte un pince-nez. L'oxygène consommé est compensé, tout au moins pendant la respiration normale entre les déterminations. Au cours des 5 premières années de cette étude le CO₂ était absorbé de manière permanente pendant toute la durée de l'épreuve. Par après nous avons apporté une légère modification à l'appareil Pulmotest ce qui nous a permis de supprimer l'absorption du CO₂ au moment de la détermination de la CV et du VEMS et de la maintenir entre les déterminations.

Le plus grand volume obtenu au cours de 3 essais consécutifs a été retenu et ramené aux conditions BTPS (c'est à dire à la température du corps (37°C), et saturé de vapeur d'eau à la pression ambiante.) Signalons que les tracés ont été mesurés par deux techniciens à des moments différents afin de rattraper des erreurs de lecture de l'ordre de 5 ou 10 millimètres papier, qui sont relativement fréquentes chez certains techniciens.

Différents facteurs qui pourraient perturber nos mesures et des variantes de technique qui pouvaient fausser la comparaison avec certaines données de la littérature ont été étudiées.

- Variabilité des mesures :

Nous avons recherché l'influence de la répétition des essais et également l'influence du moment (matin ou après-midi) de la journée et du jour de la semaine sur la détermination de la CV et du VEMS.

- Variantes de technique :

Le VEMS est mesuré sur le tracé en dessinant une verticale à l'origine de la pente abrupte du début de l'expiration rapide et en mesurant le volume expiré dans la seconde qui suit.

Chez 1574 sujets cette méthode a été comparée à la technique, dite "d'extrapolation", où la partie la plus abrupte de la courbe est extrapolée vers le haut du tracé et où le début de la seconde est déterminé par l'intersection de cette droite et du prolongement horizontal du plateau correspondant à l'inspiration maximale (Figure 2).

Nous avons également comparé chez 200 sujets, les résultats obtenus pour la CV et la FVC.

- Influence du tabac :

Nous avons recherché l'influence de l'habitude de fumer sur les valeurs moyennes obtenues. A cette fin, nos sujets ont été répartis en cinq catégories : non fumeurs, fumant moins de 20 cigarettes par jour, plus de 20 cigarettes par jour, plus de 40 cigarettes par jour et ancien fumeurs ne fumant plus.

2. Sujets examinés.

Notre population est constituée par les membres du personnel navigant et les candidats élèves pilotes qui ont été répartis en plusieurs sous-groupes (A à F) d'après leur fonction et leur qualification (Tableau 1).

GROUPE	N	AGE		TAILLE	
		moyenne	étendue	moyenne	étendue
A	327	29.0	20 - 49	175	163 - 192
B	437	34.3	22 - 53	174	160 - 190
C	201	34.2	23 - 50	173	159 - 193
D	255	29.6	19 - 48	175	162 - 191
E	259	20.1	17 - 25	175	162 - 191
F	236	21.4	17 - 28	174	161 - 194

Tableau 1 : Age et taille dans les différents sous-groupes.

- N : Nombre de sujets dans chaque groupe.
- A : Pilotes d'avions à réaction.
- B : Pilotes, navigateurs et radios d'avions de transport.
- C : Personnel navigant temporaire.
- D : Candidats et pilotes d'aviation légère.
- E : Candidats élèves pilotes déclarés aptes.
- F : Candidats élèves pilotes déclarés inaptes.

Une vingtaine de sujets ayant une histoire clinique de bronchite chronique, confirmée par la présence d'un bronchospasme ont été exclus de cette étude. Aucune autre sélection n'a été effectuée.

Nous avons également eu l'occasion d'examiner 78 candidats élèves pilotes congolais de race noire et nous comparerons leurs résultats avec ceux des élèves pilotes de race blanche.

RESULTATS

1. Etude des facteurs techniques et autres.

Une première constatation fut que pour obtenir une bonne appréciation de la valeur de la CV et du VEMS, il y a lieu de pratiquer plusieurs essais. En effet, la moyenne de la seconde valeur est statistiquement plus grande que celle de la première. (Tableau 2). Dans certains échantillons nous n'obtenons, la plus grande valeur, qu'au troisième essai. Pour cette raison, nous avons imposé au moins trois essais.

	CV ml BTPS			VEMS ml BTPS		
	1	2	3	1	2	3
100 cand	5309	<u>5337</u>	5246	4189	<u>4218</u>	4126
100 Rev	5406	<u>5431</u>	5321	4088	<u>4127</u>	4021
Total	5355	<u>5384</u>	5284	4138	<u>4171</u>	4074
58 Cand						
1r examen	5360	<u>5382</u>	5357	4297	<u>4345</u>	4330
2d examen	5377	5401	<u>5422</u>	4293	4333	<u>4341</u>
1r + 2d Ex	5368	<u>5391</u>	5389	4295	<u>4339</u>	4335

Tableau 2 : Valeurs moyennes de la CV et du VEMS lors de 3 essais consécutifs (1-2-3) pour un groupe de 100 candidats élèves pilotes (100 Cand), de 100 examens de révision (100 Rev) et pour un autre échantillon de 58 candidats élèves pilotes (58 Cand), lors d'un premier et d'un second examen effectué à un jour d'intervalle.

Le fait que les examens ont lieu le matin ou l'après-midi n'influence apparemment pas les résultats. Les différences moyennes tant pour la CV (5ml) que pour le VEMS (17ml) ne sont pas significatives, l'hypothèse zéro étant acceptée respectivement au seuil de 0,75 et de 0,25 (Tableau 3).

	N	CV ml BTPS	VEMS ml BTPS
Matin	3170	5456 ± 517	4271 ± 446
Après-midi	1337	5451 ± 508	5254 ± 454
Différence A - M			- 17
PHo		0,75	0,25

Tableau 3 : Valeurs moyennes et écart type des CV et VEMS obtenus le matin et l'après-midi.

On ne retrouve également pas de variations nettes des résultats moyens en fonction des jours de la semaine (Tableau 4). Toutefois, les variances n'étant pas homogènes, nous n'avons pas appliqué de test statistique.

	N	CV ml BTPS	VEMS ml BTPS
Lundi	1090	5430 ± 513	4250 ± 454
Mardi	749	5470 ± 502	4290 ± 434
Mercredi	957	5460 ± 521	4240 ± 466
Jeudi	735	5450 ± 498	4280 ± 438
Vendredi	976	5470 ± 529	4280 ± 443

Tableau 4 : Valeurs moyennes et écart type des CV et des VEMS en fonction du jour de la semaine.

Pour un échantillon de 1574 sujets nous observons qu'en moyenne le VEMS extrapolé est plus grand que le VEMS mesuré de manière conventionnelle. La différence de 107 ml est très significative (Tableau 5).

VEMS	N	Moyenne ml BTPS	écart type	Différence extrapolé - normal
Normal	1574	4171	563	107*
Extrapolé	1574	4278	575	

Tableau 5 : Moyennes et écart type du VEMS mesuré par une technique normale et par la technique dite " d'extrapolation ".
+ Différence très significative (T-test = 5,27).

Nous observons pour la FVC des valeurs presque toujours inférieures et rarement égales à celles de la CV. La différence moyenne est de 55 ml (Tableau 6). Cette différence doit, à notre avis, encore être plus importante si la FVC n'est pas déterminée pendant la respiration en circuit fermé comme nous l'avons fait, mais qu'elle est mesurée comme le préconisent certains auteurs, au moment où le sujet prend l'embout en bouche après l'inspiration maximale.

En effet, nous remarquons fréquemment que certains sujets ne parviennent pas à retenir leur respiration à la position inspiratoire maximale, même pendant un temps très bref. Pendant l'introduction de l'embout dans la bouche, un volume d'air plus ou moins grand sera donc réexpiré et la CV ainsi sous-estimée.

CV ml BTPS	5325 ± 729
FVC ml BTPS	5270 ± 746
Différence FVC - CV	-55

Tableau 6 : Moyennes et écart type des CV et FVC obtenus dans un échantillon de 200 candidats pilotes.

2. Formule de prédiction.

Une étude préliminaire (3) a révélé :

- a. Une distribution normale est acceptable pour les valeurs de CV et de VEMS de notre population ainsi que pour les différents sous-groupes.
- b. C'est la taille debout et l'âge qui apportent le plus d'informations quant à la valeur de différents paramètres morphologiques et de l'âge pour la prédiction de la CV et du VEMS. Le supplément d'informations apporté par la mesure de la taille assise, du périmètre thoracique maximum et de la différence entre les périmètres thoraciques maximums et minimums peut être négligée.
- c. Les résultats obtenus pour les sous-groupes n'ont jamais fait apparaître de différences significatives. Comme ces sous-groupes ne se distinguent pas plus par leur moyenne ou par leur variance nous nous sommes crû en droit de considérer tous nos sujets comme faisant partie d'une même population.
- d. Bien que la dispersion de nos valeur soit la même que dans l'échantillon de Jouasset (8), la loi CV ou $VEMS = k.T^3$ ne semble pas décrire le mieux les variations en fonction de la taille pour un âge donné (Figure 3).

En réalité, lorsqu'on essaie pour exprimer la relation CV - taille différentes formules : une droite, un polynôme du deuxième degré, une formule se rapprochant de celle de Jouasset (8), voir même un polynôme du troisième degré ou comprenant un terme exponentiel, l'écart résiduel ne varie guère. Toutefois, suite à de nombreux essais de formules et afin d'obtenir des valeurs mieux adaptées pour les sujets de grande et petite taille, nous avons été amené à retenir dans notre formule définitive un polynôme du troisième degré : CV ou $VEMS = f(T, T^2, T^3)$.

Quant à l'influence de l'âge elle peut être exprimée pour des sujets âgés de plus de 24 ans, tout aussi bien par une formule linéaire que quadratique, mais lorsque la population s'étale de 18 à 60 ans par exemple on remarque de manière constante que la courbe de CV en fonction de l'âge passe par un maximum qui se situe vers 24 ans, d'où la nécessité d'un terme exponentiel. Les meilleurs résultats ont été obtenus en introduisant dans la formule un terme en A (âge) et un second en $e^{-0,3.A}$ (e = base des loga - rithmes naturels).

Notre formule définitive revêt donc la forme suivante :

$$\begin{array}{l} \text{-----} : \\ : \\ : \text{ CV ou VEMS} = a + b.A + c.e^{-0,3.A} + d.T + f.T^2 + g.T^3 : \\ : \\ \text{-----} : \end{array}$$

Les coefficients ont été calculés pour les valeurs recueillies chaque année depuis 1961 jusqu'à 1967 (1ère à 7ème année) et également pour deux autres échantillons comprenant l'un les résultats de la première spirométrie (1ères mesures) effectuée par les sujets dans notre laboratoire, et l'autre les résultats de la deuxième spirométrie (2èmes mesures) effectuée un an plus tard.

Les examens de la sixième et septième années ont été exclus de ces deux échantillons étant donné les petites modifications de technique que nous avons apportées.

La taille des échantillons, ainsi que l'âge, la taille, la CV et le VEMS moyens des sujets sont repris dans le tableau suivant (Tableau 7). L'âge moyen est de l'ordre de 30 ans sauf pour les premières mesures où il était de l'ordre de 27 ans. La taille moyenne est partout de 174 cm à peu près.

Pour ces différents échantillons nous avons également fait calculer les coefficients pour une formule linéaire en fonction de l'âge et de la taille :

$$\begin{array}{l} \text{-----} : \\ : \text{ CV ou VEMS} = a + b.A + c.T : \\ \text{-----} : \end{array}$$

Les résultats sont repris, pour les coefficients de la formule exponentielle aux tableaux 8a et 8b, pour les coefficients linéaires au tableau 9.

Comme ces chiffres sont peu parlants par eux-mêmes, nous avons voulu les illustrer par les figures suivantes, qui montrent aux âges de 20, 35, et 50 ans, les différences qui existent entre l'évolution de la CV et du VEMS en fonction de la taille lorsque le calcul est fait pour une régression exponentielle et une régression linéaire ou pour la formule de Jouasset (8). (Figures 4, 5 et 6)

Echantillon	N	Age	Taille	CV	VEMS
1° Année	249	30,2 ± 8,2	174,1 ± 5,3	5.381 ± 643	4.152 ± 511
2° "	919	28,6 ± 5,3	174,8 ± 5,8	5.469 ± 662	4.233 ± 534
3° "	919	29,3 ± 5,4	174,6 ± 5,7	5.438 ± 649	4.263 ± 545
4° "	992	30,7 ± 6,9	174,7 ± 5,8	5.421 ± 676	4.291 ± 576
5° "	1.138	31,5 ± 6,8	174,7 ± 5,8	5.401 ± 668	4.278 ± 579
6° "	1.653	29,0 ± 8,2	174,0 ± 5,9	5.475 ± 715	4.176 ± 563
7° "	1.659	29,1 ± 8,5	174,5 ± 6,1	5.325 ± 708	4.097 ± 595
1° Mesures	<u>1.380</u>	<u>27,3 ± 7,1</u>	<u>174,6 ± 5,8</u>	<u>5.445 ± 647</u>	<u>4.309 ± 572</u>
2° "	999	29,4 ± 6,5	174,6 ± 5,8	5.435 ± 681	4.231 ± 564
Congolais	78	22,4 ± 2,5	171,2 ± 5,8	4.242 ± 644	3.448 ± 499

Tableau 7 : Taille (N), des divers échantillons étudiés avec moyenne et écarts type des âges, de la taille, de la CV et du VEMS.

$$CV = b + c.A + d.e^{-0,3A} + fT + gT^2 + hT^3$$

Echantillon	b	c	d	f	g	h
1° Année	- 90.651,81558	- 1,83216	- 7.217,52460	+ 1.561,18537	- 8,93553	+ 0,01711
2° "	- 2.894,41569	- 2,12591	- 6.527,12670	+ 45,22759	- 0,21392	+ 0,00040
3° "	- 25.125,36049	- 2,33175	- 4.183,11980	+ 425,83355	- 2,38201	+ 0,00451
4° "	+ 21.965,57224	- 2,39013	- 7.705,01770	- 386,21834	+ 2,28180	- 0,00441
5° "	- 19.096,21953	- 2,76385	- 10.451,90100	+ 322,57836	- 1,79054	+ 0,00338
6° "	- 10.897,40433	- 2,62436	- 10.548,80000	+ 177,95649	- 0,94277	+ 0,00173
7° "	+ 2.708,45944	- 3,18933	- 11.103,98000	- 56,62587	+ 0,40667	- 0,00086
1° Mesures	- 5.306,90866	- 2,12358	- 6.788,69170	+ 84,79005	- 0,42771	+ 0,00078
2° "	- 14.377,94446	- 2,27346	- 6.173,25962	+ 240,46509	- 1,31665	+ 0,00247

TABLEAU 8a : Valeurs des coefficients de la formule exponentielle donnant la capacité vitale théorique pour les différents échantillons.

$$\text{VEMS} = b + c.A + d.e^{-0,3A} + fT + gT^2 + hT^3$$

Echantillon	b	c	d	f	g	h
1° Année	- 43.364,87049	- 2,32636	- 4845,63610	+ 739,09396	- 4,17376	+ 0,00790
2° Année	- 13.075,85921	- 3,13223	- 2.649,47330	+ 222,27852	- 1,23411	+ 0,00233
3° "	- 17.675,52611	- 3,24280	+ 391,97399	+ 291,82002	- 1,57724	+ 0,00288
4° "	+ 631,72052	- 3,03764	- 272,49931	- 16,04673	+ 0,14595	- 0,00033
5° "	- 37.037,75641	- 3,44099	- 5.650,72640	+ 628,87883	- 3,52852	+ 0,00664
6° "	- 22.064,64159	- 3,37100	- 7.279,16120	+ 366,88461	- 2,00267	+ 0,00368
7° "	- 5.854,20783	- 3,22525	- 8.030,44740	+ 93,91719	- 0,47155	+ 0,00082
1° Mesures	- 28.277,49826	- 2,85555	- 2.344,41170	+ 480,94961	- 2,70544	+ 0,00510
2° "	- 16.669,25007	- 2,57777	+ 3.281,85172	+ 277,68817	- 1,51603	+ 0,00280

TABLEAU 8b : Valeurs des coefficients de la formule exponentielle donnant le VEMS théorique pour les différents échantillons.

$$CV = b + c.A + d.T$$

Echantillon	C V				V E H S			
	b	c	d		b	c	d	
1° Année	- 725,67497	- 0,78591	+ 7,39312		- 391,83968	- 1,65738	+ 4,92158	
2° Année	- 662,79634	- 1,33932	+ 7,14014		- 302,64129	- 2,82452	+ 4,61552	
3° "	- 604,32763	- 1,85544	+ 6,88687		- 286,74383	- 3,33875	+ 4,64382	
4° "	- 610,23801	- 1,60500	+ 6,87760		- 295,84836	- 3,02114	+ 4,67963	
5° "	- 601,85620	- 1,81560	+ 6,86535		- 290,42150	- 2,95315	+ 4,64455	
6° "	- 716,21936	- 0,72142	+ 7,38120		- 340,57564	- 2,06175	+ 4,69941	
7° "	- 640,46447	- 1,19433	+ 6,92055		- 318,45517	- 2,37597	+ 4,56839	
1° Mesures	- 623,37380	- 1,10577	+ 6,86126		- 339,91861	- 2,64244	+ 4,82763	
2° "	- 590,36932	- 1,88492	+ 6,82401		- 291,96793	- 2,83118	+ 4,59124	

TABLEAU 9 : Valeurs des coefficients des formules linéaires donnant la CV et le VEH S pour les différents échantillons.

3. Influence de la race.

La comparaison de la courbe obtenue pour les sujets de race noire et celle que nous obtenons pour un groupe de sujets belges ayant le même âge moyen montre que ces courbes ont la même allure, mais qu'elles sont décalées. Les sujets de race noire ont, à taille et âge égal, une CV et un VEMS qui sont 20% plus petits. (Figures 7 - 8)

4. Influence du tabac.

Le tableau 10 montre que pour la CV la moyenne est plus élevée chez les sujets fumant moins de 20 cigarettes par jour que chez ceux qui ne fument pas. Par contre, elle est moins bonne chez ceux qui fument plus de 40 cigarettes par jour et fort curieusement elle est la plus élevée chez ceux qui ont abandonné l'habitude de fumer.

C A T E G O R I E	N	C V	
		moyenne	écart type
Non fumeurs	1219	5490	505
Fument - de 20 cigar./jour	1537	5530	498
Fument + de 20 cigar./jour	1230	5490	517
Fument + de 40 cigar./jour	34	5350	435
Ne fument plus	49	5720	567

Tableau 10 : Influence de l'habitude de fumer sur la Capacité Vitale.

En ce qui concerne le VEMS, les résultats paraissent plus logiques. (Tableau 11)

C A T E G O R I E	N	VEMS	
		moyenne	écart type
Non fumeurs	1219	4310	463
Fument - de 20 cigar./jour	1537	4280	449
Fument + de 20 cigar./jour	1230	4210	435
Fument + de 40 cigar./jour	34	4200	425
Ne fument plus	49	4330	396

Tableau 11 : Influence de l'habitude de fumer sur le VEMS.

Les moyennes du VEMS s'abaissent progressivement avec l'augmentation de la consommation de tabac. Mais ici également, se sont ceux qui ont abandonné la cigarette qui obtiennent le meilleur résultat.

5. Etude longitudinale.

Comme nous l'avons déjà signalé et pour des raisons de technique de mesure, cette étude a également été limitée aux résultats obtenus lors des cinq premières années. L'élaboration de la loi CV en fonction du temps peut être envisagée de la manière suivante :

Si nous calculons pour chaque individu une régression linéaire des valeurs de CV en fonction de l'âge, on obtient une droite dont le coefficient angulaire (b) doit correspondre pour chaque âge moyen (\bar{A}) à la tangente de la loi générale qui lie CV en fonction de l'âge. (Figure 9)

Chez 739 sujets qui avaient 4 ou 5 mesures consécutives, chacune à un an d'intervalle, b et \bar{A} ont été calculés. Après avoir vérifié ensuite que les variances intra-individuelles des CV étaient homogènes, nous avons fait calculer le coefficient déterminant l'évolution de b en fonction de l'âge et avons obtenu:

$$b = -3,15 + 4.445,18.e^{-0,3.\bar{A}} \quad (a)$$

Si nous intégrons l'équation (a) nous retrouvons la CV :

$$CV = k - 3,15.A - 14.817,25.e^{-0,3.A} \quad (b)$$

Cette formule, non définitive, nous permet de prédire pour chaque individu l'évolution ultérieure de sa CV en fonction de l'âge, dès que la CV a été mesurée par un premier examen.

DISCUSSION ET CONCLUSIONS

Notre étude nous a révélé qu'il y a lieu de pratiquer au moins trois essais afin d'obtenir une bonne appréciation de la valeur de la CV et du VEMS. Toutefois, le thermomètre à mercure introduit dans la tuyauterie du spiromètre à la sortie de la cloche, ne semble pas suivre de manière suffisamment précise, les fluctuations réelles de température dans la cloche de l'appareil, de sorte qu'à l'heure actuelle et sans autres contrôles, nous n'avons pas voulu nous prononcer sur l'évolution exacte des valeurs lors d'une succession de plus de trois essais.

Le fait que la spirométrie de nos sujets pourrait, au cours des années, être effectuée une fois le matin, l'autre fois dans l'après-midi, n'introduit pas d'erreur systématique. L'influence du jour de la semaine paraît également négligeable.

Bien que les résultats nous apprennent que la valeur moyenne obtenue pour un VEMS "extrapolé" soit significativement plus grande, nous pensons devoir rejeter cette méthode étant donné que, par l'extrapolation, nous créons sur le tracé un volume qui, hypothétiquement, aurait pu être soufflé par le sujet mais qui, en réalité, ne l'a pas été.

Lors de la comparaison avec certaines données de la littérature, il faudra tenir compte du fait que la FVC donne des valeurs inférieures à celles de la CV.

Quant à l'influence du tabac et, quoique nos résultats concordent avec ceux décrits par Blackburn et coll. (4), nous pensons que compte tenu de l'effectif réduit dans les deux dernières catégories et, de l'incertitude qui plane quant à la sincérité des déclarations recueillies, les résultats doivent être interprétés avec la plus grande réserve.

Nous nous sommes demandés si les chiffres obtenus par notre formule exponentielle de prédiction étaient comparables aux valeurs théoriques de CV et de VEMS de la littérature des dernières années. Pour répondre à cette question nous n'avons retenu que les études effectuées sur un grand nombre de sujets.

Certains auteurs, comme Ferris et coll. (6) et Kory et coll. (9) proposent une loi linéaire ; Jouasset (8) un rapport avec le cube de la taille, tout en tenant compte du facteur âge, et De Kroon et coll. (5) une loi exponentielle. Le tableau 12 vous montre les types de formules, l'écart résiduel, le coefficient de la variation et le coefficient de corrélation (R) indiqués dans ces études.

Quelques figures illustrent mieux les différences entre ces valeurs théoriques.

Auteur	N	Type de formule	écart résiduel	éc. rés. moyenne	R
BANDE	1.715	CV } = $a + bA + c.e^{-0,3A + dT + fT^2 + gT^3}$	0,50	0,09	0,64
		VEMS }	0,45	0,10	0,61
JOUASSET	3.153	CV } = $k.T^3$ $k = f(A)$	-	0,09	-
	2.536	VEMS }	-	0,10	-
DEKROON	1.076	CV } = $10a + b2A . T^{b1}$	0,52	0,13	0,70
		VEMS }	0,68	0,17	0,67
FERRIS	298	CV } = $a + bA + cT$	0,59	-	0,69
		VEMS }	0,49	-	0,71
KORY	468	CV } = $a + bA + cT$	0,58	0,12	0,64
	389	VEMS }	0,52	0,13	0,63

Tableau 12 : Comparaison de notre formule à celles proposées dans les études de Jouasset, de De Kroon, de Ferris et de Kory.

La taille des échantillons (N), l'écart résiduel, le rapport : écart résiduel sur moyenne et le coefficient de corrélation multiple (R) ont également été renseignés.

Pour les valeurs de la CV en fonction de la taille à 21 ans (Figure 10), nous voyons que les auteurs américains Ferris (6) et Kory (9) ont les CV les plus basses. Ceci s'explique par une différence de technique et de calcul des résultats.

Ferris mesure une FVC obtenue en faisant expirer rapidement les sujets à partir d'une inspiration profonde. De plus, sa valeur est une valeur moyenne et non une valeur maximale comme pour nos travaux, ainsi que ceux de Jouasset (8) et de De Kroon (5). Les valeurs de Kory (9) sont également des valeurs moyennes. Les normes de De Kroon (5) sont très proches des nôtres.

Par contre, nous voyons que, les valeurs de la CECA sont plus faibles pour les individus de petite taille et plus élevées pour les individus de grande taille. A 49 ans (Figure 11) nous retrouvons à peu près les mêmes différences. Le fait que nos valeurs sont ici en moyenne plus élevées que celles de De Kroon et coll.(5) pourrait s'expliquer par la meilleure motivation de nos sujets.

La figure 12 montre l'évolution du VEMS en fonction de la taille, à 21 ans. Les valeurs des différents auteurs correspondent mieux, exceptées celles de la CECA qui sont à nouveau plus faibles pour les sujets plus petits et plus élevées pour les sujets plus grands. A 49 ans, (Figure 13) nous observons le même tableau, sauf pour les valeurs de la CECA qui concordent plus ici que pour les petits sujets, étant nettement plus élevées pour les individus de grande et moyenne taille.

Nous voyons donc qu'à partir de notre population de pilotes et de candidats élèves pilotes - qui aux yeux de certains pourrait paraître hautement sélectionnée - nous obtenons des valeurs théoriques de CV et de VEMS très proches de celles obtenues par De Kroon (5) avec une autre formule dans une population d'ouvriers d'usine. Par contre, les normes de la CECA ne paraissent applicables qu'aux sujets de taille et d'âge moyens, car ils sousestiment la valeur de CV et de VEMS des individus de petite taille et sur-estiment les valeurs des individus de grande taille.

En résumé, nous constatons donc que pour les sujets d'âge et de taille moyens, la formule employée importe peu, mais que pour les plus âgés et que pour les sujets de grande taille et, en moindre mesure, pour les sujets de petite taille, la formule exponentielle répond mieux à la réalité. De plus la formule linéaire ne peut pas être extrapolée pour des âges inférieurs à 22, 23 ans où elle s'écarte de trop de la courbe CV en fonction de l'âge.

D'autre part nous observons que bien que l'analyse statistique

n'a pas démontré - à peu d'exceptions près - de différences significatives entre les coefficients des divers échantillons étudiés, on note néanmoins une variabilité de ces coefficients qui changent parfois même de signe. Il suffit donc qu'au cours d'études transversales effectuées à des moments différents une légère modification de l'âge moyen de l'échantillon, de la taille ou de la technique se produise pour provoquer une variations des valeurs théoriques normales, surtout en ce qui concerne le VEMS (Figure 14).

En outre, malgré l'emploi d'une formule de régression fort complexe, il persiste un écart résiduel important, ce qui veut dire que la CV ou le VEMS d'un individu doit s'écarter de plus de 18 à 20% de la valeur moyenne avant de pouvoir être considéré comme anormal.

Les résultats obtenus sur un petit échantillon de sujets congolais confirment les observations faites par Abramovitz et coll.(1) : les Africains ont à âge et taille égale une CV et un VEMS inférieur de 20% à ceux de sujets de race blanche, mais l'évolution des valeurs de CV et de VEMS en fonction de la taille est parallèle.

Etant donné l'imprécision des valeurs obtenues par les formules de prédiction, nous avons essayé d'obtenir de meilleurs résultats par une étude longitudinale de la CV observée d'année en année chez la même personne.

A la lumière des premiers résultats de cette étude nous avons été amenés à concevoir le problème des valeurs théoriques d'une manière différente pour les examens initiaux et pour les examens de revision.

Pour le sujet qui se présente une première fois à l'examen les valeurs de CV et de VEMS observées seront interprétées en les comparant aux valeurs théoriques moyennes que nous avons établies en fonction de l'âge et de la taille, grâce à la formule exponentielle de notre étude transversale.

Tandis que pour l'évolution ultérieure de valeurs nous calculerons, grâce à la loi en fonction de l'âge que nous nous avons obtenue par notre étude longitudinale, le score que ce sujet doit obtenir au cours des années suivantes. Une simple comparaison de la valeur mesurée au score théorique permettra de déceler avec beaucoup de précision, les écarts à l'évolution normale des paramètres ventilatoires étudiés.

BIBLIOGRAPHIE.

1. ABRAMOVITZ S. , LEINER G.C., LEWIS W.A. and SMALL M.J.: "Vital capacity in the negro". Amer. Rev. resp. Disc., 92 : 287 - 292 (1965).
2. BALDWIN E.D.F., COURNAND A. and RICHARDS D.W.Jr.: "Pulmonary insufficiency. I. Physiological classification, clinical methods of analysis, standards values in normal subjects". Med. (Baltimore), 27 : 243 - 278 (1948).
3. BANDE J.: "Valeurs de la capacité vitale et du volume expiratoire maximal/ seconde dans un groupe de 1715 sujets normaux". J. Physiol. (Paris) 57 : 545 - 546 (1965).
4. BLACKBURN H., TAYLOR H.L., PARLIN R.W., KIELBERG J. and KEYS A. : "Physical activity of occupation and cigarette smoking". Arch. Environm. Health, 10 : 312 - 322 (1965).
5. DE KROON J.P.M., JOOSTING P.E. et VISSER B.F.: "Les valeurs normales de la capacité vitale et du volume expiratoire maximum seconde. (Recherche chez les ouvriers d'une aciérie aux Pays - Bas). Arch. mal. Prof. 25 : 17 - 30 (1964).
6. FERRIS B.G.Jr., ANDERSON D.O. and ZICKMANTEL R.: "Prediction values for screening tests of pulmonary function". Amer. Rev. resp. Dis., 91 : 252 - 261 (1965).
7. HUTCHINSON J.: "On the capacity of lungs and on respiratory functions with view of establishing a precise and easy method of detecting disease by spirometer". Tr. Med. Chir. Soc. London, 29 : 137 - 248 (1846).
8. JOUASSET D.: "Normalisation des épreuves fonctionnelles respiratoires dans les pays de la communauté européenne du charbon et de l'acier". Poumon et coeur, 16 : 1145 - 1159 (1960).
9. KORY R.C., CALLAHAN R., BOREN H.G. and SYNER J.C.: "The veterans Administration-Army cooperative study of pulmonary function. I. Clinical spirometry in normal men". Amer. J. Med., 30 : 243 - 258 (1961).
10. TIFFENEAU R., BOUSSER J. et DRUTEL P.: "Capacité vitale et capacité pulmonaire utilisable à l'effort. Critères statiques et dynamiques de la ventilation pulmonaire". Paris méd. (partie Méd), 39 : 543 - 547 (1949).

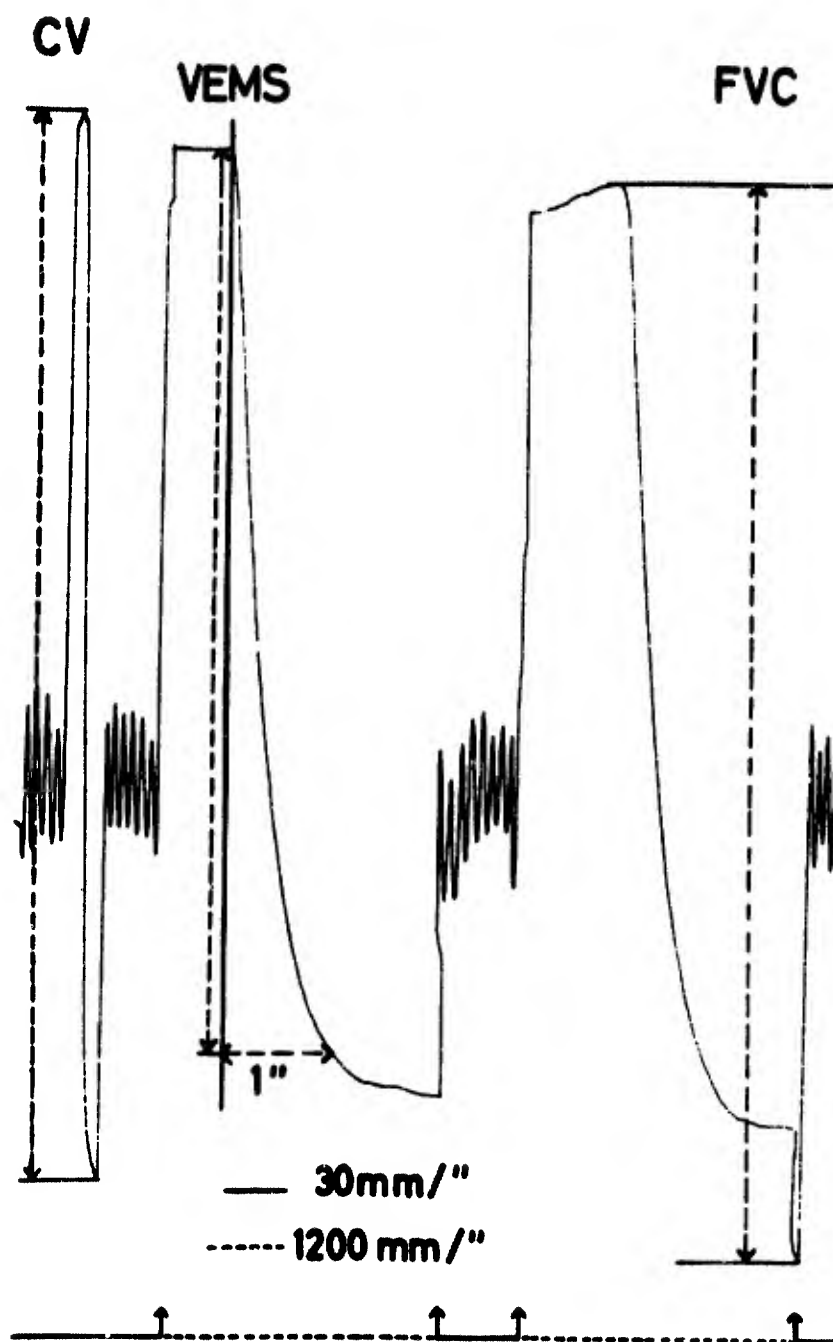

Figure 1 : Tracé de Capacité Vitale (CV), de volume expiratoire maximum seconde (VEMS) et de capacité vitale forcée (FVC).

Au bas est indiquée la vitesse de déroulement du papier (30mm/min et 1.200mm/min).

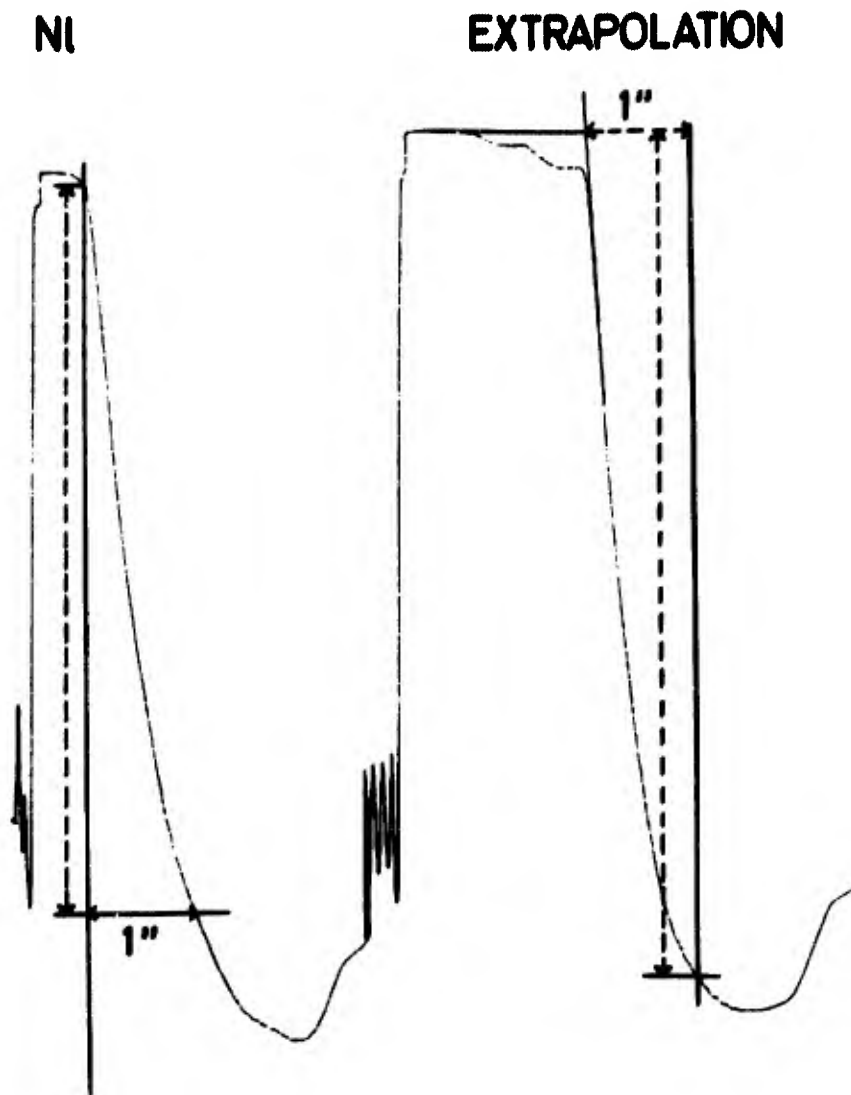

Figure 2 : Variante de technique de mesure du volume expiratoire maximum seconde sur le tracé.

- NI : méthode classique.
- Extrapolation : technique dite "d'extrapolation" (Voir texte).

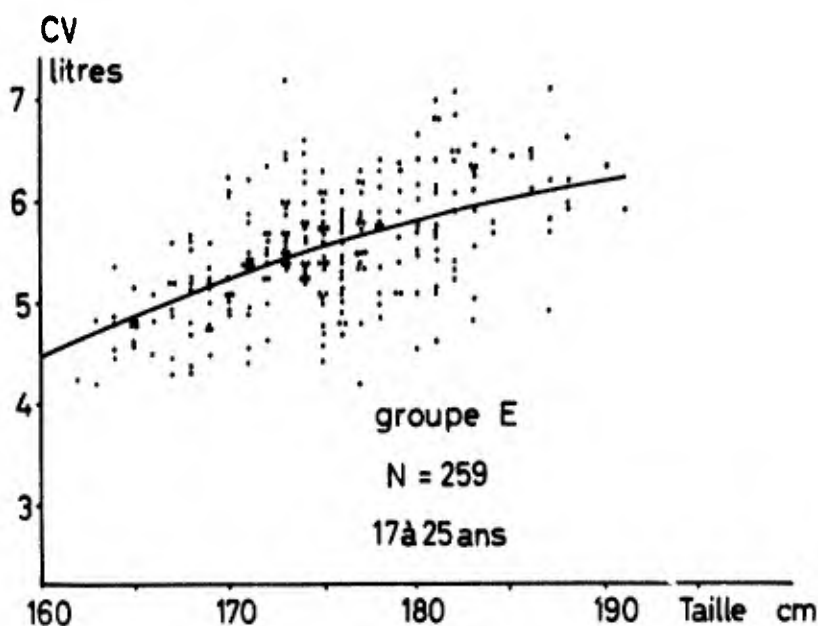

Figure 3 : Dispersion de la CV en fonction de la taille pour un groupe de 259 candidats élèves pilotes déclarés aptes.

La courbe représente la meilleure régression exponentielle calculée sur ces valeurs.

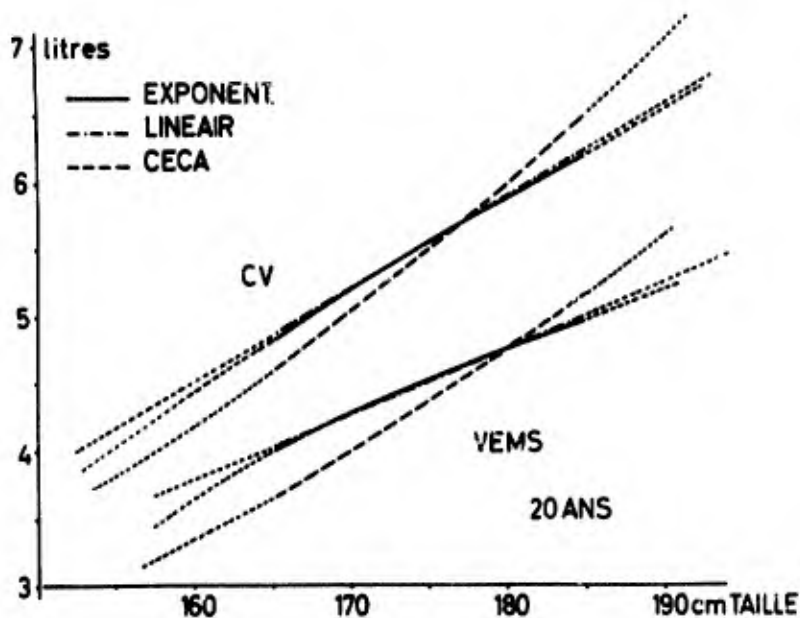

Figure 4 : Evolution de la capacité vitale (CV) et du volume expiratoire maximum seconde en fonction de la taille obtenu par notre formule exponentielle et linéaire de prédiction et par la formule de JOUASSET (CECA) à l'âge de 20 ans.

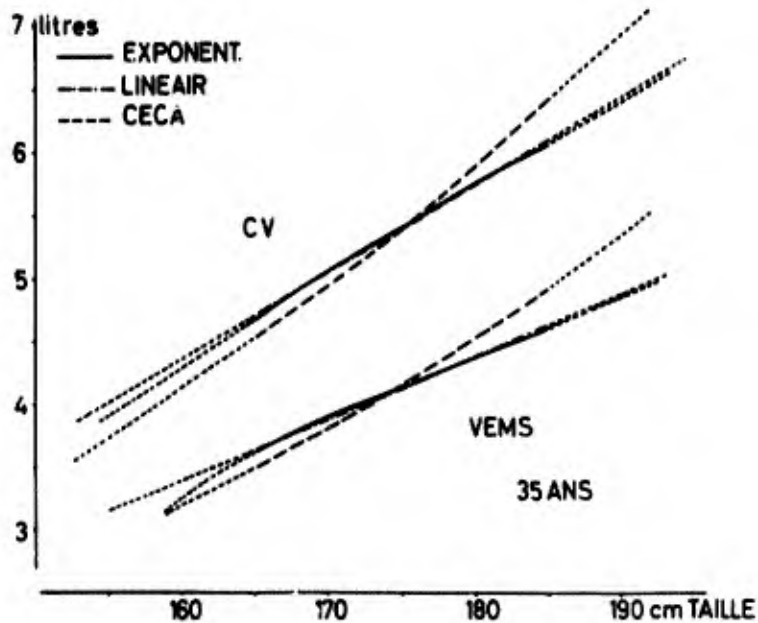

Figure 5 : Evolution de la capacité vitale (CV) et du volume expiratoire maximum seconde en fonction de la taille obtenu par notre formule exponentielle et linéaire de prédiction et par la formule de JOUASSET (CECA) à l'âge de 35 ans.

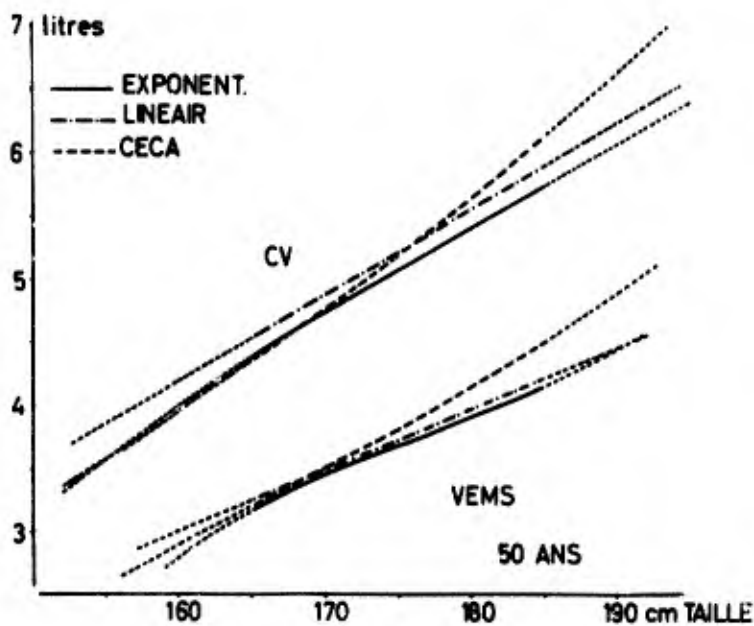

Figure 6 : Evolution de la capacité vitale (CV) et du volume expiratoire maximum seconde en fonction de la taille obtenu par notre formule exponentielle et linéaire de prédiction et par la formule de JOUASSET(CECA) à l'âge de 50 ans.

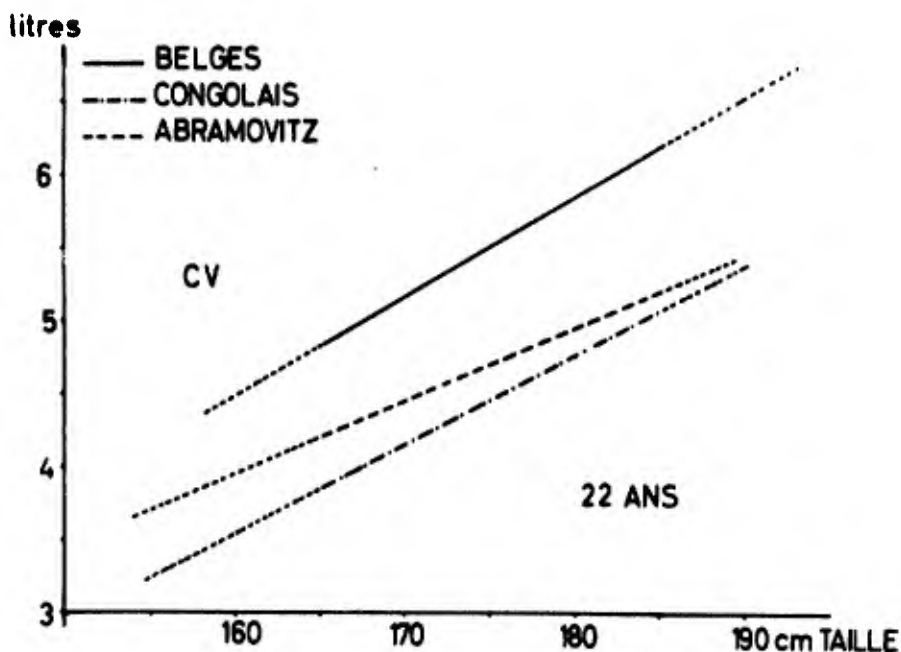

Figure 7 : Comparaison de la capacité vitale (CV) en fonction de la taille à l'âge de 22 ans chez les candidats élèves pilotes belges, congolais et chez les sujets de race noire (Formule d'ABRAMOVITZ).

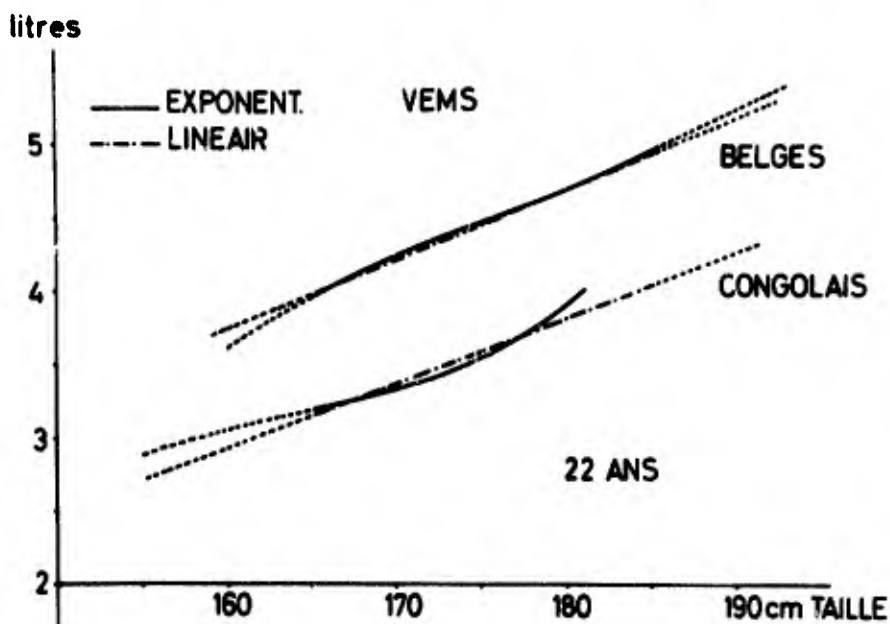
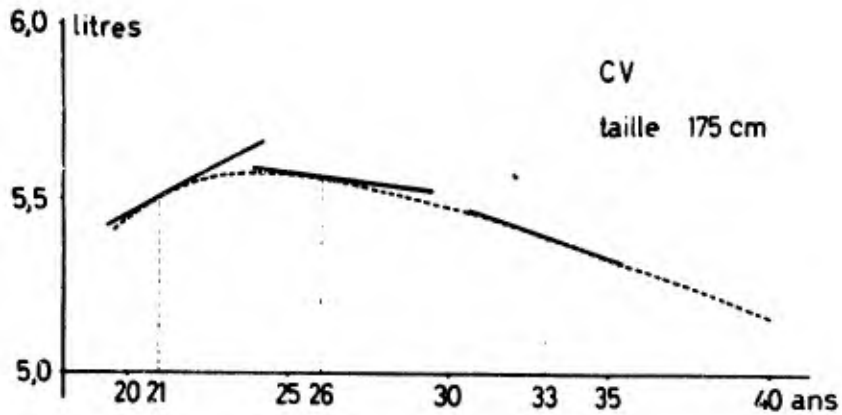

Figure 8 : Evolution du volume expiratoire maximum seconde (VEMS) en fonction de la taille obtenu par les formules exponentielles et linéaires de prédiction, à l'âge de 22 ans, pour des candidats élèves pilotes belges et congolais.



$$b = -3,155 + 4445,177 \cdot e^{-0,3A}$$

$$CV = k - 3,155A - 14.817,246 \cdot e^{-0,3A}$$

Figure 9 : Evolution de la capacité vitale (CV) en fonction de l'âge pour une taille de 175cm.

Les droites représentent les tangentes à la courbe aux âges moyens de 21, 26 et 33 ans (Voir texte).

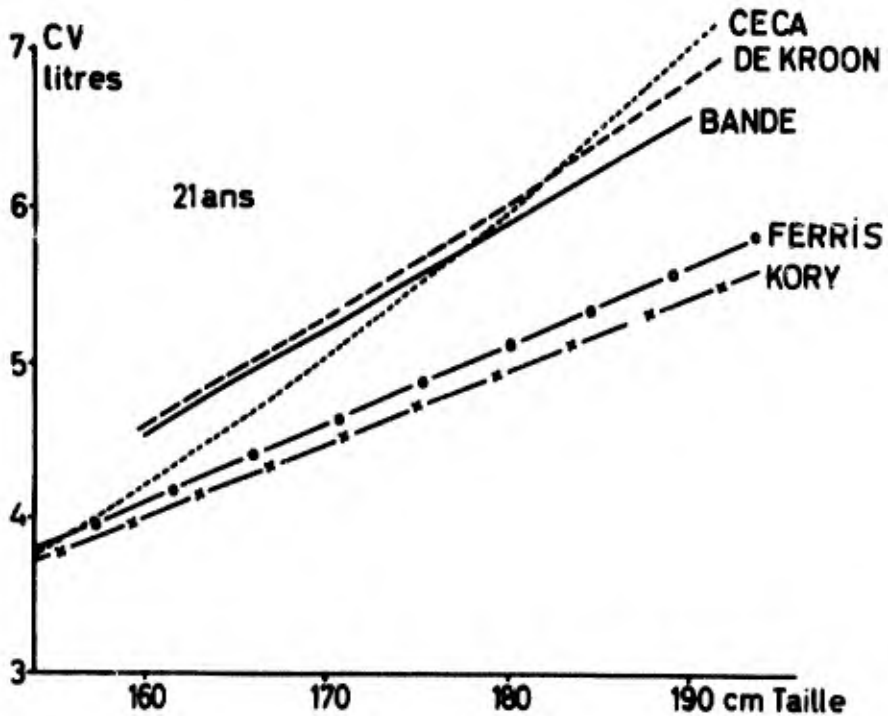

Figure 10 : Evolution de la capacité vitale (CV) en fonction de la taille à l'âge de 21 ans d'après différentes formules de prédiction.

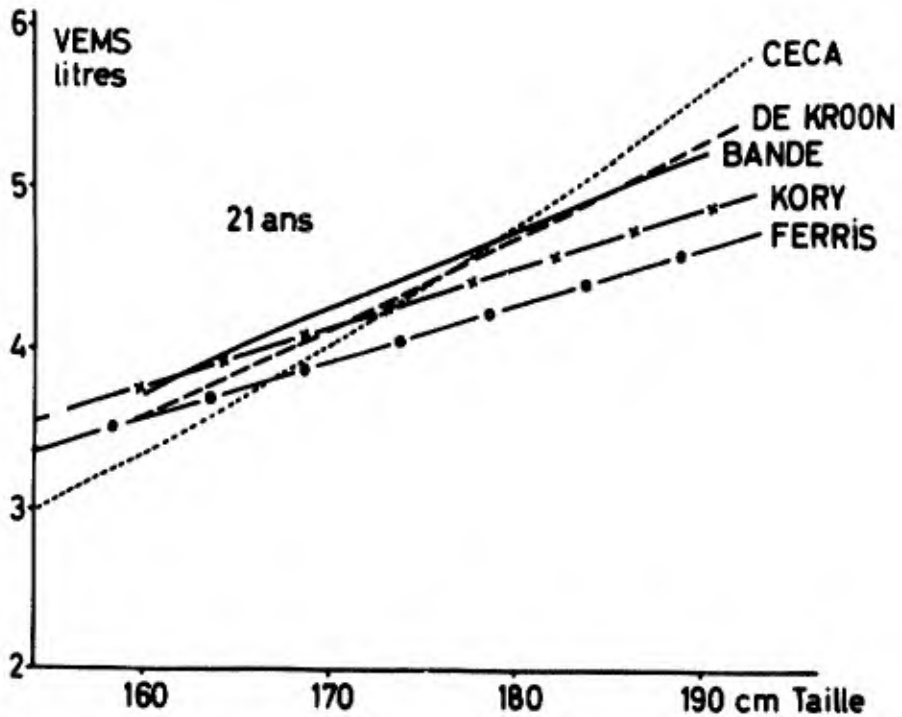

Figure 11 : Evolution du volume expiratoire maximum/seconde (VEMS) en fonction de la taille à l'âge de 21 ans d'après différentes formules de prédiction.

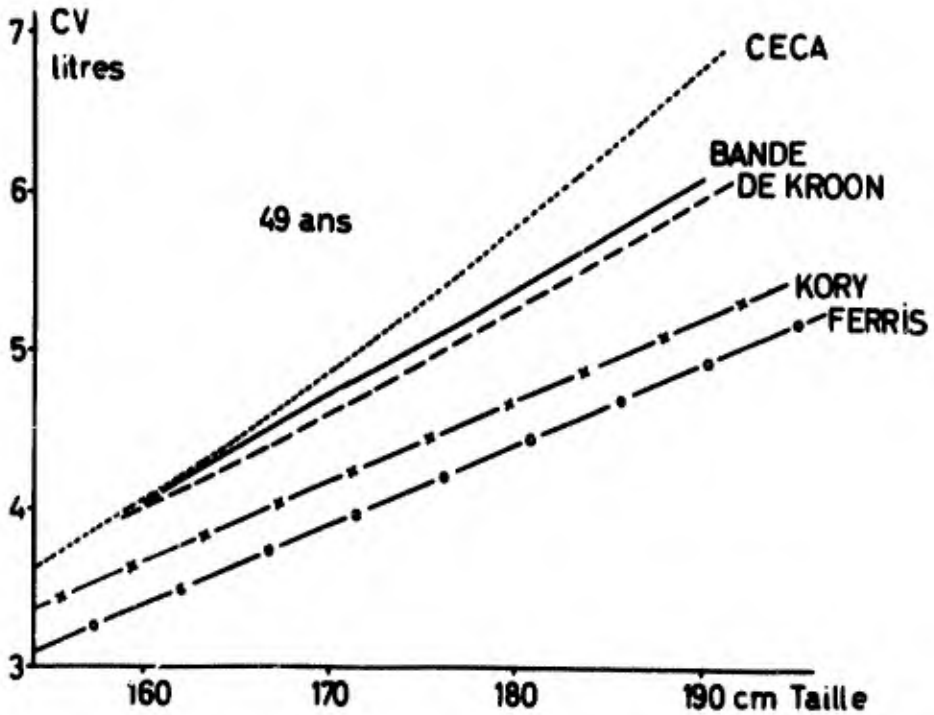

Figure 12 : Evolution de la capacité vitale (CV) en fonction de la taille à l'âge de 49 ans d'après différentes formules de prédiction.

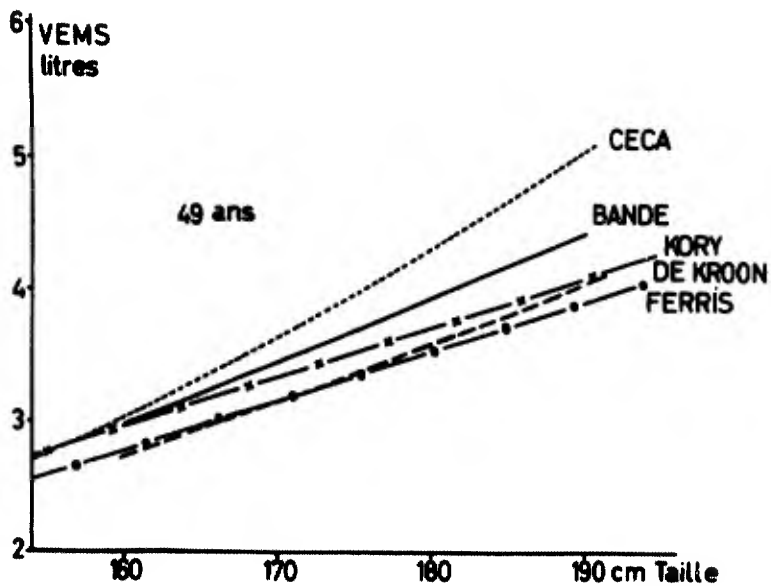

Figure 13 : Evolution du volume expiratoire maximum/seconde (VEMS) en fonction de la taille, à l'âge de 49 ans, d'après différentes formules de prédiction.

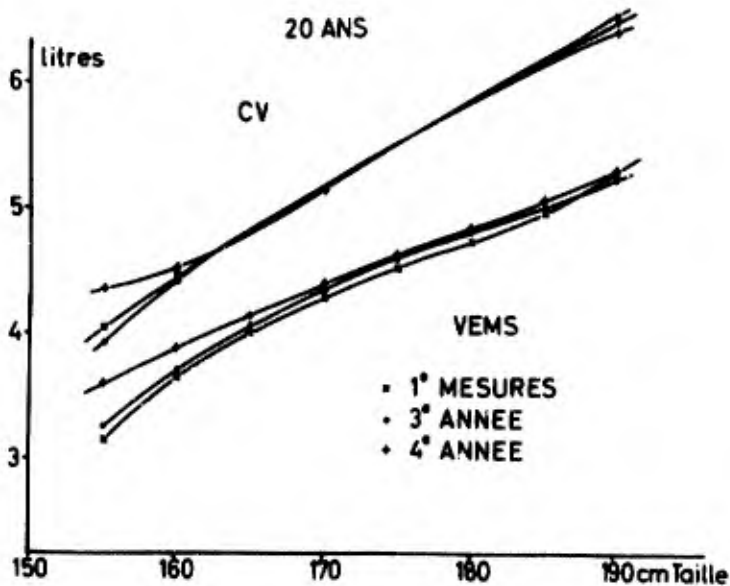

Figure 14 : Différences observées entre les valeurs théoriques normales de capacité vitale (CV) et le volume expiratoire maximum/seconde (VEMS) à l'âge de 20 ans.

Seules les courbes des échantillons (1^o mesures, 3^o année et 4^o année) ayant donné les écarts maxima ont été reproduites.

ANALYSE MATHÉMATIQUE DU TRACE DE L'ÉPREUVE
D'EXPIRATION FORCÉE

par

Capitaine médecin J. Clément* et Docteur K. Van De Woestyne†

* du Centre de Médecine aéronautique de la Force aérienne Belge
† de la clinique St Raphaël, Université de Louvain

RESUME

D.P. Schilder a proposé de décrire la plus grande partie de la courbe des débits expiratoires forcés F , comprise entre son maximum et la fin de l'expiration, en fonction du volume V par l'équation:
 $F = AV^2 + BV + C$ (1).

Si cette équation possède deux racines réelles distinctes, il est possible d'exprimer F et V en fonction du temps t par

$$(2) \quad V_t = V_\infty \frac{\omega^t - 1}{\omega^t - \delta} \quad \text{où } V_\infty, \omega \text{ et } \delta \text{ sont des paramètres constants}$$

$$(3) \quad F_t = \frac{\omega^t}{(\omega^t - \delta)^2} [V_\infty(1 - \delta) \lg \omega] .$$

Les auteurs ont appliqué les formules (1), (2) et (3) sur des tracés d'expiration forcée de spiromètre et de pneumotachographe, par une méthode de régression alinéaire sur 15 points de la courbe choisis conventionnellement à intervalles équitemporels de 0,2 secondes à partir du moment du débit maximum. Le but poursuivi était de vérifier les limites de validité des formules et la reproductibilité des volumes relatifs théoriques $q_t = \frac{V_t}{V_\infty}$ aux temps 0,2 et 1 seconde, ainsi que celle des paramètres A, B, C .

La méthode de découpage de tracé adoptée ne permettait pas toujours d'arriver à une solution réelle des racines de l'équation (1), notamment chez les sujets pathologiques souffrant d'obstruction bronchique.

Chez les autres sujets il fut trouvé que les équations (2) et (3) ne sont valables qu'entre les temps 0,4 et 3 secondes, et que l'équation (1) ne pouvait être rejetée entre 35 et 98 pourcent de la capacité vitale, 100% correspondant à la fin de l'expiration.

La reproductibilité des volumes relatifs théoriques à 1 seconde est comparable à celle des volumes expiratoires maximums seconde; celle de $q_{0,2}$ est moins bonne. La reproductibilité de la forme générale de la courbe des F en fonction de V est excellente comme en témoignent les limites de tolérance du flux théorique.

ANALYSE MATHÉMATIQUE DU TRACE DE L'ÉPREUVE D'EXPIRATION FORCÉE

Capitaine médecin J. Clement et Docteur K. Van De Woestyne

L'école de D. Fry s'est intéressée au débit expiratoire en fonction du volume pulmonaire lors des épreuves d'expiration forcée, et Schilder (1) a proposé, sur la base d'un modèle physique, d'exprimer quadratiquement la relation qui lie le débit F au volume V selon l'équation $F = AV^2 + BV + C$ (1), et ce pour la plus grande partie de la courbe des débits comprise entre son maximum et la fin de l'expiration. Au cas où la relation (1) possède deux racines réelles distinctes, c à d si le discriminant $D = B^2 - 4AC > 0$, le volume V_t en fonction du temps peut s'écrire:

$$V_t = V_\infty \cdot \frac{\omega^t - 1}{\omega^t - \delta} \quad (2)$$

où V_∞ est un volume asymptotique et ω, δ des constantes sans dimension, avec:

$$\omega = e^{\sqrt{D}}; \quad \delta = \frac{-B - \sqrt{D}}{-B + \sqrt{D}}; \quad V_\infty = \frac{-B - \sqrt{D}}{2A} \quad (3)$$

Le flux F_t sera donné par:

$$F_t = \frac{\omega^t}{(\omega^t - \delta)^2} \cdot [V_\infty(1 - \delta) \cdot \lg \omega] \quad (4)$$

Nous nous sommes proposés d'appliquer les équations (2) et (4) à des tracés de volumes expiratoires forcés provenant d'enregistrements spirométriques et de pneumotachographe intégré, dans le but:

- (a) d'examiner la reproductibilité des paramètres A, B, C et du paramètre $q_t = \frac{V_t}{V_\infty}$ que nous appelons volume relatif théorique.
- (b) et d'autre part d'examiner les limites de validité de ces formules.

MÉTHODE D'ANALYSE ET D'ESTIMATION

La courbe des volumes expirés fut conventionnellement découpée à partir du point d'inclinaison maximum en portions équitemporelles de 0,2 secondes (Fig. A) sur une durée de 3 secondes, et les volumes correspondant à chaque temps V'_t fut mesuré.

Pour chaque tracé on dressa une liste de 15 couples de valeur \bar{F}_t , \bar{V}_t où \bar{F}_t représente le débit moyen soufflé entre les temps $(t - 1)$ et $(t + 1)$, c à d

$$\bar{F}_t = \frac{V'_{t+1} - V'_{t-1}}{2} \quad (F \text{ étant exprimé par } 0,2 \text{ seconde})$$

et \bar{V}_t représente le volume moyen entre ces mêmes temps, moyenne calculée par la méthode approchée de Simpson:

$$\bar{V}_t = \frac{V'_{t+1} + V'_{t-1} + 4V'_t}{6}$$

A travers les 15 couples \bar{F}_t , \bar{V}_t on ajuste une régression quadratique F sur V qui fournit une estimation des paramètres A , B , C et par calcul déductif direct à l'aide des formules (3), une estimation des paramètres V_∞ , ω et δ . Ce procédé est valable pour l'estimation de ω , qui élevé à la puissance de la variable fixe t ne permet pas de meilleure évaluation. Toutefois, les paramètres V_∞ et δ autorisent une estimation plus précise en appliquant la méthode de régression linéaire à deux variables sur la fonction (2) transformée en

$$V_t = V_\infty \left[\frac{\omega^t - 1}{\omega^t} \right] + \delta \left[\frac{V_t}{\omega^t} \right]$$

où les quantités entre crochets deviennent les nouvelles variables fixes.

Cependant, étant donné la longueur des calculs, et ayant constaté que leur application n'améliore la précision que de façon peu importante dans le cadre du but poursuivi, nous avons appliqué directement les formules (3). D'autre part il a été décidé de construire une régression par tracé, car les erreurs de mesure étant du même ordre à chaque niveau, la régression pouvait être traitée en homoscedastique: cette méthode n'aurait pu être appliquée sur des moyennes de différents tracés, car la variance du débit à volume fixe diminue avec l'accroissement de celui-ci.

EXPERIMENTATION

Les expériences ont été effectuées sur 17 sujets normaux et 3 pathologiques atteints d'obstruction bronchique chronique, ayant soufflé chacun 4 fois consécutivement à travers un pneumotachographe avec intégrateur, relié directement les 3 premières fois à un spiromètre, et la 4^o fois déconnecté de celui-ci. Seules les épreuves 2, 3, et 4 ont été retenues pour examen.

Le pneumotachographe était du type Siemens avec cône de Fleish, et l'intégrateur était un élément d'intégrateur analogique EAI avec inscripteur U.V. de type "Hewlett Packard".

RESULTATS

Les 3 individus pathologiques, et un des sujets normaux ont présenté avec la méthode adoptée de découpage du tracé un discriminant D négatif. Par conséquent les formules (2) et (4) ne leur étaient pas applicables; leurs tracés ont été écartés de la présente analyse.

Sur les 48 tracés des 16 individus restants l'application de la méthode fut telle qu'illustrée par la Figure A reproduisant une courbe de pneumotachographe: les cercles et carrés moirs représentent les volumes et flux théoriques calculés au départ des équations (2) et (4), après évaluation numérique de leurs paramètres selon le procédé indiqué plus haut.

Le Tableau B montre les valeurs moyennes \bar{x} des volumes relatifs théoriques aux temps 0,2 et 1 secondes, pour l'intégrateur et le spiromètre, avec leurs écarts types $s_{rés}$ et coefficients de variation $s_{rés}/\bar{x}$ intraindividuels. La reproductibilité est bonne sauf pour le $q_{0,2}$ spirométrique. Ce dernier fait peut s'expliquer notamment par la difficulté de repérage visuel du point d'inclinaison maximum vu l'absence d'enregistrement du débit sur ces graphiques.

D'autre part il existe une augmentation significative Δ des $q_{0,2}$ et $q_{1,0}$ de l'intégrateur lorsque celui-ci est connecté au spiromètre: il peut s'agir soit d'un effet de fatigue, quoique celui-ci semble invraisemblable et n'est pas constaté sur les épreuves 2 et 3 spirométriques, ou bien plus probablement d'une influence directe du circuit spirométrique sur les débits.

Par contre, il n'existe pas de différence significative entre les valeurs de q spirométriques et celles de l'intégrateur lors des mesures simultanées.

Le Tableau C indique les valeurs moyennes \bar{x} , écarts types s_{intra} , et coefficients d'intercorrélation r intraindividuels des paramètres A, B, C, lorsque les volumes sont exprimés en pourcent de la capacité vitale, 100% correspondant à la fin de l'expiration.

Ces chiffres sont nécessaires à la détermination des limites de confiance de la régression quadratique moyenne montrée en Figure F. s/c et $r_{AB/C}$ sont les valeurs correspondantes lorsque C est considéré comme fixé.

La Figure D indique les différences en cm^3 entre les volumes théoriques et les réels en fonction du temps, avec leurs écarts-types interindividuels. Ces différences sont minimales, de l'ordre de 20 cc, avec une allure descendante générale entre 0,4 et 3 secondes. Par contre elles augmentent manifestement à 0,2 sec. où elles atteignent 50 cc, et à la fin de l'épreuve où elles arrivent à -50 cc mais avec une très forte variabilité inter-individuelle. L'équation (2) est donc satisfaisante entre 0,4 et 3 secondes, mais s'écarte de la réalité au-delà de ces limites, quoique d'une manière peu importante.

La Figure E montre les différences $F_t - F'_t$ en cc/sec entre les flux théoriques et réels en fonction du temps (à gauche) et des volumes moyens correspondants à ces temps (à droite).

Les écarts sont faibles, sauf au temps 0, où le flux maximum est fortement surestimé, l'erreur étant de l'ordre de 20%. D'après le graphique de droite, à volumes en abscisse, il serait possible de réduire les différences pratiquement à zéro entre 0,2 et 3 secondes avec une régression quadratique correctrice. L'équation (4) décrit donc la réalité entre 0,2 et 3 secondes avec bonne approximation, mais non en-deçà.

La Figure F dessine la régression quadratique moyenne F (en trait gras), sur V exprimé en % de la capacité vitale, celle-ci étant choisie comme moyenne de deux mesures sur pneumotachogramme. Les limites de confiance sont en traits fins, celles de tolérance en traits interrompus.

Les cercles noirs figurent les débits réels moyens correspondant aux volumes réels moyens et une ellipse de dispersion pour V_0 . On voit que la formule de Schilder concorde bien avec les valeurs expérimentales entre 44 et 98% de la capacité vitale. La ligne des débits réels (non indiquée sur la figure) ne sort de la surface de confiance qu'au plus tôt à 35% de la capacité vitale, puisqu'elle ne présente ni angle ni discontinuité.

L'équation (1) ne peut donc être rejetée entre 35 et 98% de la cap. vit. La limite de tolérance inférieure de probabilité 0,975 ne peut être considérée comme rectiligne. L'hypothèse de linéarité de la fonction débit - volume doit donc être repoussée. La fonction des débits réels présente manifestement deux courbures, l'une convexe vers l'axe des abscisses suit la régression quadratique, l'autre concave s'écarte de cette régression; il serait par conséquent utile de tester par une méthode semblable l'équation proposée par CARA qui considère l'accélération expiratoire comme fonction linéaire du flux et du volume:

$$\frac{d^2V}{dt^2} = A \frac{dV}{dt} + BV + C$$

REFERENCE

Effect of gas density and viscosity on the maximal expiratory Flow-Volume relationship, by D.P.SCHILDER, A.ROBERTS, and D.L.FRY (from the section of clinical biophysics, cardiology Branch, National Heart Institute, Bethesda, Md): Journal of Clinical Investigation, Vol.42, No.11, 1963.

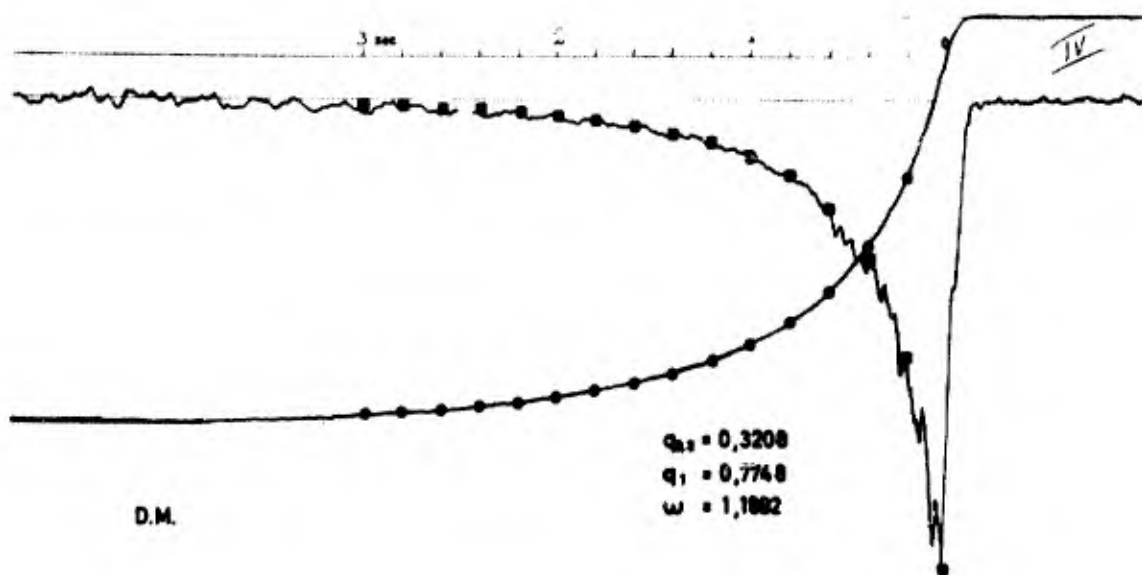

Figure A

TABLEAU B

$q_t = \frac{V_t}{V_\infty}$				
	$q_{0.2s}$		$q_{1.0s}$	
	Intégr.	Spirom.	Intégr.	Spirom.
\bar{x}	0,3777	0,3910	0,8411	0,8648
$s_{rés}$	0,0149	0,0355	0,0221	0,0239
$s_{rés}/\bar{x}$	3,9%	9,1%	2,6%	2,7%
Δ	+0 0098		+0 0160	

TABLEAU C

$F_t = AV^2 + BV + C$ (ml/s)			
	A	B	C
R	0,7035	-199,70	12.800
S_{intra}	0,1765	29,05	1.695
r	$r_{AB} = -0,93$	$r_{BC} = -0,85$	$r_{AC} = 0,63$
$S _C$	0,1375	15,30	
$r_{AB C}$	-0,96		

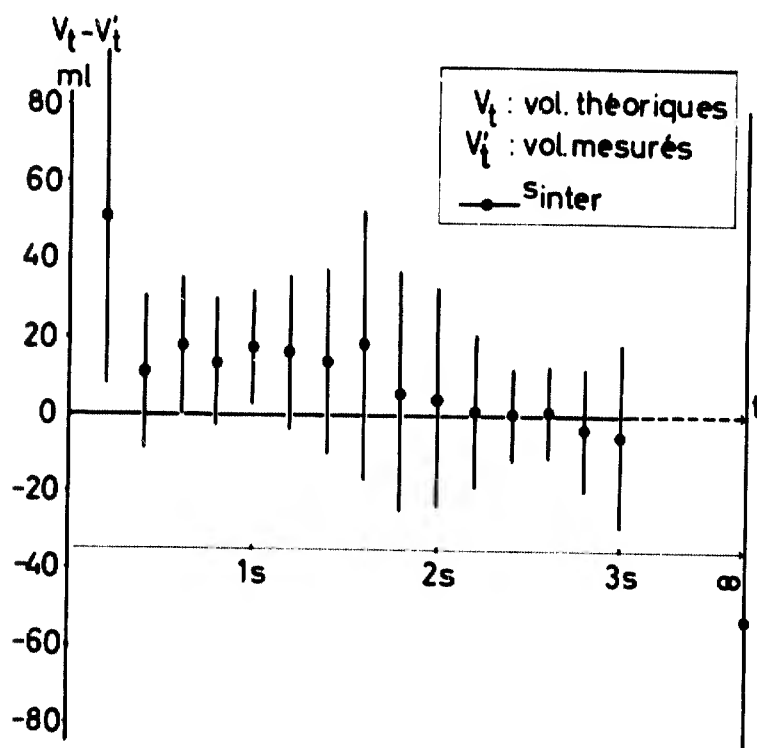

Figure D

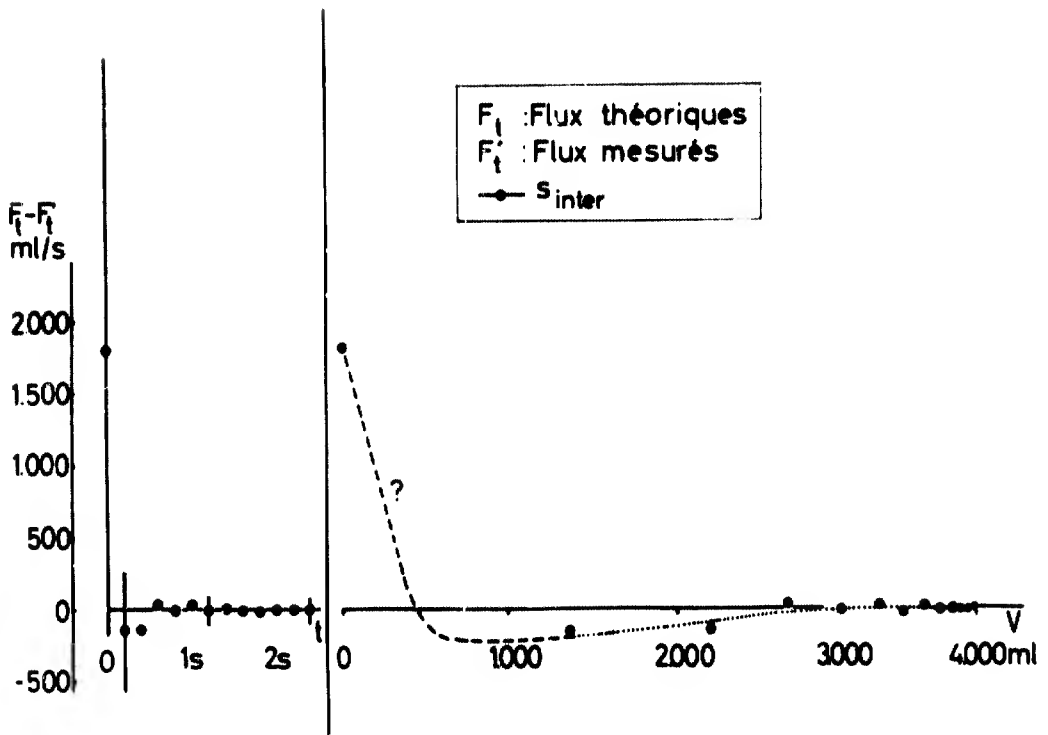

Figure E

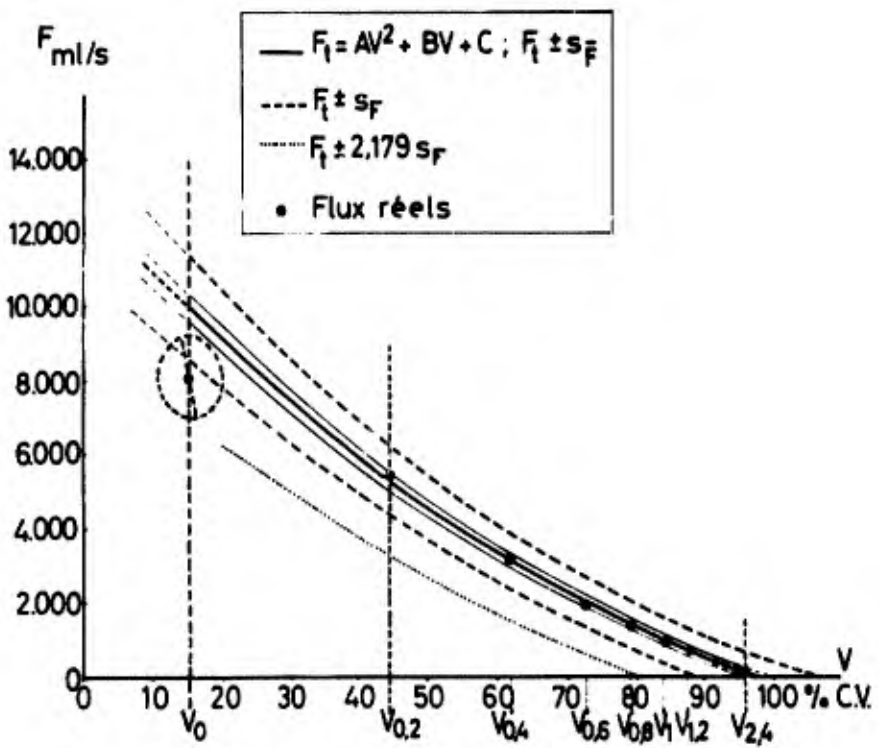

Figure F

BLANK PAGE

ETUDE CRITIQUE ET STATISTIQUE DE LA VALEUR DE DIVERS TESTS
D' ATTENTION UTILISES POUR LA SELECTION DES PILOTES

par

Dr Paul Lievens

Major-Médecin,
Neuro-Psychiatre de la Force
Aérienne Belge

RESUME

L'auteur a étudié les résultats obtenus aux 3 facteurs du Bourdon-Wiersma, la vitesse, la précision et la dispersion maximale des temps par ligne de 447 candidats élèves pilotes belges, en rapport avec la réussite et l'échec aux divers niveaux de l'entraînement.

Deux ordres de constatations : 1) Les normes utilisées actuellement et établies sur des candidats pilotes néerlandais devraient être modifiées pour être utilisées sur la population belge et le système de correction du test devrait être revu.

2) Il y a des différences significatives entre les sujets qui réussissent et les sujets qui échouent, portant plus sur la précision au début de l'entraînement et plus sur les autres facteurs aux autres niveaux. Le groupe des sujets obtenant le brevet de pilote se distingue de ceux qui échouent en cours de route par un plus petit nombre d'omissions pour une vitesse d'exécution moyenne.

En conclusion, l'auteur pense pouvoir affirmer que parmi les facteurs qui interviennent dans ce test d'attention c'est la précision pour une vitesse d'exécution moyenne qui sont les plus importants. Le bon candidat pilote est celui qui commet le moins d'omissions en un temps moyen. Le Bourdon-Wiersma en mesurant cette efficience, non en mesurant une certaine quantité de bon travail par unité de temps, mais un plus petit nombre d'oublis pour un travail donné est un bon test d'attention.

ETUDE CRITIQUE ET STATISTIQUE DE LA
VALEUR DE DIVERS TESTS D'ATTENTION
UTILISES POUR LA SELECTION DES PILOTES.

Dr. Paul LIEVENS
Major-Médecin
Neuro-Psychiatre de la Force
Aérienne Belge

INTRODUCTION

Une étude préliminaire (1) nous a montré qu'aucun de nos tests faisant intervenir l'attention, à savoir la mesure des temps de réaction complexes, le test de Schulte et le test de barrage de Bourdon-Wiersma n'était en corrélation significative avec la réussite à l'entraînement de pilote. Les résultats obtenus à ces tests par les sujets devenant pilotes n'étaient pas significativement différents de ceux obtenus par les sujets échouant à l'entraînement.

Nous avons dès lors choisi de faire une étude analytique du test de Bourdon-Wiersma en nous intéressant plus particulièrement aux corrélations entre la réussite aux divers niveaux de l'entraînement du pilote et les résultats obtenus aux divers facteurs du test. Il s'agit donc d'une étude atomistique qui doit aboutir à une meilleure compréhension du test lui-même et viser à une certaine étude des aptitudes exigées des élèves-pilotes.

Une interview menée auprès des moniteurs de l'Ecole de Pilotage Elémentaire (E.P.E.) a révélé qu'ils estiment les 3 facteurs suivants comme essentiels pour la réussite des candidats : la motivation, l'habileté générale et une bonne attention diffuse, par quoi ils entendent une aptitude du sujet à surveiller plusieurs choses à la fois. Il s'agit donc d'une forme d'attention multiple, c'est-à-dire, appliquée à des tâches multiples mais conjuguées et organisées en un tout.

Or le Bourdon-Wiersma exige précisément du sujet une application à une tâche monotone, tâche pendant laquelle, à chaque barrage il faut une attitude d'attente, en ce sens qu'une situation donnée va se modifier et qu'il faut s'y préparer pour la percevoir et réagir correctement, et une attitude d'observation faite d'une participation volontaire du sujet à l'épreuve et d'une inhibition des activités étrangères.

LE TEST DE BOURDON-WIERSMA

Il s'agit d'un test individuel du type "papier-crayon", composé de 50 lignes consécutives, constituées chacune de 25 signes formés chacun de 3, 4 ou 5 points et distribués au hasard. En travaillant de gauche à droite, le sujet doit barrer ligne par ligne et le plus rapidement possible, tous les signes composés de 4 points.

Ce test a été soumis par Van Wulfften-Palthe (3,4) à une étude approfondie visant la standardisation, l'étalonnage, la fidélité et la constance, ce qui a permis d'établir la technique de correction suivante.

Quatre facteurs sont retenus pour l'appréciation des résultats et les études sur des sujets normaux Néerlandais de sexe masculin de 18 à 30 ans ont permis de trouver pour ces 4 facteurs les valeurs moyennes suivantes :

- temps global :
 - 10 minutes - 1 point par minute en plus,
+ 1 point par minute en moins;
- nombre d'omissions :
 - 15 - 1 point par 5 omissions en plus,
+ 2 points par 5 omissions en moins;
- nombre d'erreurs :
 - 2 - 1 point par faute en plus,
+ 2 points par faute en moins;
- dispersion des temps fractionnaires(:) :
 - 6 - 2 points par unité supplémentaire,
+ 10 points par unité en moins.

En partant d'une moyenne arbitraire de 60 points on ajoute ou on soustrait des points de bonification et de pénalisation suivant les résultats obtenus dans les 4 facteurs. Le résultat ainsi obtenu constitue la cote définitive du test.

Signalons que Van Wulfften-Palthe (4) a montré que la répétition du test montrait de variations intra-individuelles insignifiantes.

(:) c'est-à-dire l'écart entre le temps minimum et maximum mis par le sujet pour terminer chaque ligne.

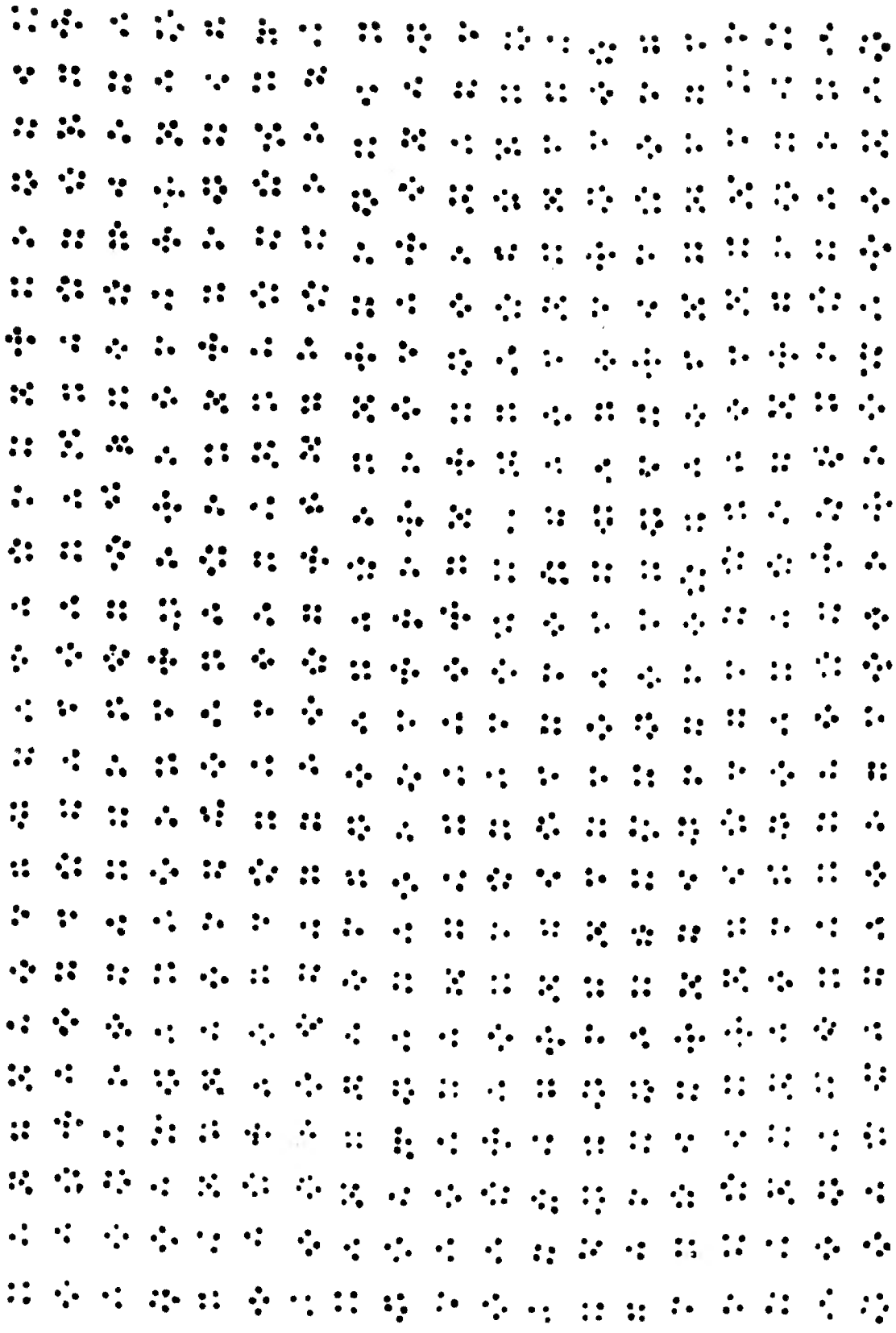

Fragment du Bourdon-Wiersma montrant une vingtaine de lignes

POPULATION ETUDIEE

Le test de Bourdon-Wiersma a été appliqué à 1.105 sujets qui se sont présentés volontairement comme candidats élèves pilotes à la Force Aérienne Belge de 1958 à 1964. Ce groupe peut être considéré comme relativement homogène au point de vue du niveau intellectuel (moyen ou supérieur) en raison même des exigences du recrutement. En effet, pour poser sa candidature le sujet doit avoir terminé le cycle supérieur de l'enseignement secondaire.

Ce groupe comprend :

- 625 candidats déclarés aptes après avoir passé les examens médicaux, les tests psycho-techniques et l'interview;
- 480 candidats déclarés inaptes à l'issue de ces examens.

A noter qu'aucune élimination n'a été pratiquée sur la base des résultats obtenus au Bourdon-Wiersma mais que ceux-ci intervenaient dans le calcul du stanine.

Un premier fait doit être signalé dès maintenant. Les résultats obtenus par ces deux groupes (voir le tableau I) montrent des différences qui au test du médian se révèlent significatives. Les inaptes au Centre de Médecine Aéronautique (C.M.A.) obtiennent pour les trois facteurs, temps global, nombre d'omissions et dispersion, des résultats significativement moins bons que les sujets déclarés aptes.

Ces deux groupes ont en effet une population répartie différemment de part et d'autre des médians communs de ces 3 facteurs et ne peuvent donc être mélangés.

	Temps global	N.Omissions	Dispersion
	m	m	m
N.total (1.105)	10'50"	16,09	7,07
Aptes CMA (N = 625)	10'36"	15,30	6,57
Inaptes CMA (N = 480)	11'09"	17,30	7,71
Normes de Van Wulfften Palthe (N = 1.193)	10	15	6

Tableau I. (explications dans le texte).

Nous pouvons avec nos sujets former deux groupes, celui des sujets déclarés aptes au CMA et celui des sujets déclarés inaptes au CMA. Pour l'objet de ce travail, seul le groupe des sujets déclarés aptes est étudié ici. Cependant, un certain nombre de sujets aptes ne se sont pas engagés (N = 178) bien qu'ils aient été admis, de sorte qu'il ne nous reste que 447 sujets qui ont commencé l'entraînement.

Nous avons utilisé pour la correction du test les normes de Van Wulfften-Palthe établies sur des candidats pilotes parce que nous savons qu'en ce qui concerne la cote finale du test, il n'y a pas de différence significative entre les résultats de Van Wulfften-Palthe et ceux obtenus sur des sujets belges masculins

candidats pilotes (2). Mais à notre grand étonnement nous trouvons pour certains facteurs du test des résultats s'écartant des normes néerlandaises.

Pour le groupe dans sa totalité nous observons que 65 % de nos sujets ne commettent aucune erreur et que 21 % ne commettent qu'une erreur alors que Van Wulfften-Palthe admet normalement en moyenne 2 erreurs. Les sujets belges obtiendront donc une bonification. Il n'en va pas de même pour le facteur "dispersion" pour lequel le groupe total obtient en moyenne 7 (norme néerlandaise = 6) ce qui entraîne donc une pénalisation. Si on considère le sous-groupe des inaptes au CMA la différence est plus nette encore. Par contre, si on considère le sous-groupe des aptes au CMA, nous voyons qu'il est assez comparable à celui de Van Wulfften-Palthe sauf en ce qui concerne le nombre des erreurs. Nous n'avons pas d'explication pour ces faits mais ils incitent à envisager une étude plus approfondie pour vérifier s'il n'est pas indiqué d'adopter des normes belges.

PROCEDURE

L'essentiel de notre méthode de travail est que nous n'avons plus tenu compte du score final du test. Ce score final n'indique pas toujours la valeur réelle de la performance au test parce qu'il exprime en un seul chiffre l'influence de 3 facteurs différents, la vitesse, la précision et la dispersion extrême des temps par ligne. De plus les études antérieures (2,5) ont montré que la corrélation entre le résultat global au Bourdon-Wiersma

et la réussite ou l'échec dans la formation de pilote était soit faible soit nul, ce que nous avons constaté également dans une étude récente faite sous notre direction par Brams (1).

Dans un but purement scientifique nous avons voulu calculer la corrélation entre la réussite ou l'échec dans l'entraînement des pilotes et les résultats obtenus aux 4 facteurs du Bourdon-Wiersma.

Notre hypothèse de travail est que la réussite ou l'échec dans la formation de pilote est corrélée avec un ou plusieurs facteurs du Bourdon-Wiersma, alors que le score global ne permet pas de différencier ces groupes. Une hypothèse subsidiaire est qu'il y a peut-être une corrélation entre la réussite ou l'échec à un des niveaux de l'entraînement et l'un ou l'autre facteur du Bourdon-Wiersma.

Nous avons réparti les sujets déclarés aptes au CMA et qui ont entrepris l'entraînement, groupe G (N = 447) d'après les échecs aux divers niveaux de l'entraînement, ce qui nous donne 4 groupes :

- groupe D : sujets ayant échoué à l'Ecole de Pilotage Elémentaire (EPE) : 236 (53 %)
- groupe C : sujets ayant échoué à l'Ecole de Pilotage Avancé (EPA) : 72 (16 %)
- groupe B : sujets ayant échoué à l'Ecole de Pilotage de Transition (EPT) : 12 (3 %)
- groupe A : sujets ayant obtenu le brevet de pilote : 127 (28 %).

En comparant les groupes nous pourrions vérifier si les résultats obtenus aux divers facteurs du Bourdon-Wiersma sont significativement différents et donc susceptibles éventuellement de discriminer ces groupes; en d'autres mots s'ils sont en corrélation avec la réussite ou l'échec au niveau considéré.

Remarquons que les éliminations aux divers niveaux considérés et surtout au niveau D se font dans plus de 95 % des cas pour inaptitude professionnelle estimée par les moniteurs.

RESULTATS

Le tableau II résume sous forme de moyenne et d'écart type les résultats obtenus aux trois facteurs essentiels du Bourdon-Wiersma par les 4 groupes.

Nous avons dû traiter les résultats obtenus pour le facteur "erreur" de manière particulière étant donné que leur distribution n'est pas normale. Il s'agit d'une distribution discontinue pour laquelle nous avons vérifié si elle était de type Poisson, binomiale ou géométrique. Le calcul montre que la variance est nettement plus grande que la moyenne ce qui nous fait rejeter les hypothèses poissonnienne et binomiale. L'hypothèse géométrique (Polya) a été validée par la méthode du chi carré. Les comparaisons des diverses distributions observées avec la distribution globale de notre groupe des aptes n'a donné pour aucun groupe un résultat significatif.

Nous ne pouvons donc dire qu'il y a une différence entre les sous-groupes constitués au point de vue nombre des erreurs commises. A noter que notre population commet en moyenne moins d'erreurs que la population néerlandaise.

		Temps global		N.Omissions		Dispersion	
Groupes	N	m	σ	m	σ	m	σ
G * A+B+C+B	447	10'30"	1'31"	15,16	10,89	6,81	2,59
D	236	10'31"	1'29"	15,53	11,23	6,79	1,65
C	72	10'18"	1'33"	15,20	10,93	6,51	1,71
B	12	9'54"	1'26"	21,75	15,12	7,00	1,15
A	127	10'39"	1'34"	13,85	9,37	7,00	1,92
E = D+C+B	320	10'27"	1'30"	15,68	11,38	6,73	1,66
E' = C+D	308	10'28"	1'30"	15,44	11,16	6,72	1,67
R = A+B+C	211	10'34"	1'35"	14,76	10,48	6,83	1,69
R' = B+A	139	10'35"	1'34"	14,53	10,27	7,00	1,76

Tableau II (explications dans le texte).

a) Au niveau de l'Ecole de Pilotage Elémentaire (EPE)

Comparaison	Temps global			N.Omissions			Dispersion		
	t	.05	.01	t	.05	.01	t	.05	.01
D/R(=A+B+C)	1,056	NS	NS	2,131	S	NS	0,540	NS	NS

Les 211 sujets qui réussissent (groupe R) ne se distinguent pas significativement de ceux qui échouent à l'EPE au point de vue temps global et au point de vue de la dispersion maximale des temps fractionnaires par ligne. Mais ce groupe commet significativement moins d'omissions.

b) Au niveau de l'Ecole de Pilotage Avancé (EPA)

De ces 211 sujets qui poursuivent l'entraînement 72 sont éliminés à l'EPA.

Comparaisons	Temps global			N.Omissions			Dispersion		
	t	.05	.01	t	.05	.01	t	.05	.01
R'/C	2,676	S	S	0,952	NS	NS	2,332	S	NS
R'/D	1,096	NS	NS	2,301	S	NS	1,666	NS	NS
R'/E' (=C+D)	2,178	S	NS	2,392	S	NS	2,536	S	NS
C/D	2,827	S	S	0,634	NS	NS	2,916	S	S

Le groupe des 139 élèves pilotes qui réussissent à l'EPA ($R' = B+A$) ne se distingue pas significativement de celui qui échoué (C) au point de vue du nombre des omissions. Il s'en distingue au point de vue du temps global et au point de vue de la dispersion maximale des temps fractionnaires par ligne. Ces différences sont significatives au seuil de .05. Ce groupe a cependant moins d'omissions.

La comparaison de ce groupe R' avec celui qui a échoué à l'EPE (D) ne montre pas de différence significative au point de vue du temps global et de la dispersion des temps fractionnaires par ligne, mais il en montre une

au point de vue de la précision.

c) Au niveau de l'Ecole de Pilotage de transition (EPT)

De ces 139 sujets qui poursuivent l'entraînement 12 sont éliminés à l'EPT. 127 élèves obtiennent le brevet de pilote.

Comparaisons	Temps global			N.Omissions			Dispersion		
	t	.05	.01	t	.05	.01	t	.05	.01
A / B	3,600	S	S	4,650	S	S	0,	NS	NS
B / D	4,061	S	S	5,020	S	S	0,	NS	NS
B / C	0,444	NS	NS	3,480	S	S	1,980	NS	NS

Le groupe (B) est composé de sujets rapides mais qui commettent beaucoup d'omissions. Le groupe (A) des sujets obtenant finalement le brevet de pilote ne se distingue pas significativement du groupe (B) au point de vue de la dispersion maximale des temps fractionnaires. Il s'en distingue significativement au point de vue du temps global et de la précision. Il est à noter cependant que ce groupe (B) ne comprend que 12 sujets. Cet échantillon est un peu petit pour permettre des conclusions valables qui sont cependant dans la ligne générale des observations.

ETUDE STATISTIQUE DU GROUPE DES SUJETS DEVENUS PILOTES

Qu'est-ce qui caractérise le groupe (A) formé des élèves pilotes obtenant le brevet de pilote, par rapport au divers autres groupes qui échouent ?

Comparaisons	Temps global			N.Omissions			Dispersion		
	t	.05	.01	t	.05	.01	t	.05	.01
A / B	3,600	S	S	4,650	S	S	0,	NS	NS
A / C	3,376	S	S	1,901	NS	NS	3,576	S	S
A / D	0,742	NS	NS	3,652	S	S	2,234	S	NS
A/E(=B+C+D)	3,845	S	S	4,643	S	S	3,312	S	S

- a) En ce qui concerne le temps global : Le groupe (A) se distingue significativement des groupes (B) et (C) et de l'ensemble des sujets qui ont échoué en cours de formation (E). Le temps global moyen est légèrement plus long. Par contre le groupe (A) ne se distingue pas significativement du groupe (D) qui a échoué à l'EPE et son temps global moyen est assez proche de celui de tous les sujets qui ont entrepris l'entraînement.
- b) En ce qui concerne le nombre d'omissions : Le groupe (A) se distingue significativement du groupe des sujets qui ont échoué aux divers niveaux de l'entraînement.
- c) En ce qui concerne le nombre des erreurs : Le groupe (A) ne se distingue pas significativement des autres groupes qui échouent.
- d) En ce qui concerne la dispersion : Le groupe (A) se distingue significativement du groupe des sujets qui ont échoué à l'EPE et à l'EPA et du groupe total des sujets qui ont entrepris l'entraînement et ont échoué.

A remarquer que pour ce facteur c'est une plus grande dispersion qui est en corrélation avec la réussite

à l'entraînement.

COMMENTAIRES

Nous avons rassemblé nos résultats en un graphique qui exprime l'évolution des cotes obtenues aux trois facteurs essentiels du Bourdon-Wiersma en rapport avec les niveaux de l'entraînement.

Nous observons que les sujets brevetés pilotes sont en moyenne un peu plus lents que la moyenne des sujets qui ont échoué mais que la vitesse moyenne d'exécution de la tâche des groupes qui réussissent à chaque niveau reste assez constante et est proche de la moyenne générale du groupe des sujets aptes à l'entrée. Tout se passe comme si les deux derniers niveaux de l'entraînement, l'EPA et l'EPT éliminaient les sujets à vitesse rapide, comme si l'entraînement tendait à conserver les sujets à vitesse moyenne. A noter qu'à l'EPE le ou les facteurs psychologiques à la base de la vitesse d'exécution ne semblent pas jouer de rôle car il n'y a pas de différence significative entre le groupe de pilotes brevetés et le groupe des sujets qui ont échoué à l'EPE, au point de vue du temps global.

Nous observons également que les pilotes brevetés sont des sujets qui ont commis significativement moins d'omissions au test. Ils sont donc plus précis et ce pour un temps d'exécution significativement plus long que ceux qui échouent, mais tout de même près de la moyenne. On peut admettre que l'entraînement élimine les sujets rapides

faisant beaucoup d'omissions. Ceci est particulièrement vrai au niveau de l'EPT. Cependant au niveau de l'EPE c'est le facteur "précision" seul qui a sélectionné les élèves qui ont par ailleurs une vitesse d'exécution moyenne. Il peut paraître banal de constater que globalement les sujets à vitesse plus lente fassent moins d'omissions, soient plus précis. Mais cette vitesse plus lente est, par rapport à l'ensemble de la population examinée une vitesse moyenne et est d'ailleurs pareille à celle des sujets qui échouent à l'EPE. Nous pouvons donc penser à juste titre que le bon candidat est celui qui, à une vitesse d'exécution au test moyenne est le plus précis et que ce n'est pas celui qui est précis pour une vitesse d'exécution lente.

En ce qui concerne le facteur "dispersion des temps fractionnaires par ligne" nous constatons paradoxalement que les sujets obtenant leur brevet de pilote ont une plus grande dispersion que les sujets qui échouent. Nous disons paradoxalement parce que la cotation du test prévoit une pénalisation pour la valeur obtenue. Ce facteur distingue surtout les candidats au niveau de l'EPA et pas aux autres niveaux. Il semble que l'entraînement élimine au niveau de l'EPA les sujets à dispersion étroite c'est-à-dire peu variables. Mais l'importance de ce facteur doit être négligeable au point de vue prédictif si on considère que sa valeur pour les sujets obtenant leur brevet est très proche de la valeur obtenue par l'ensemble des sujets qui se sont présentés au CMA.

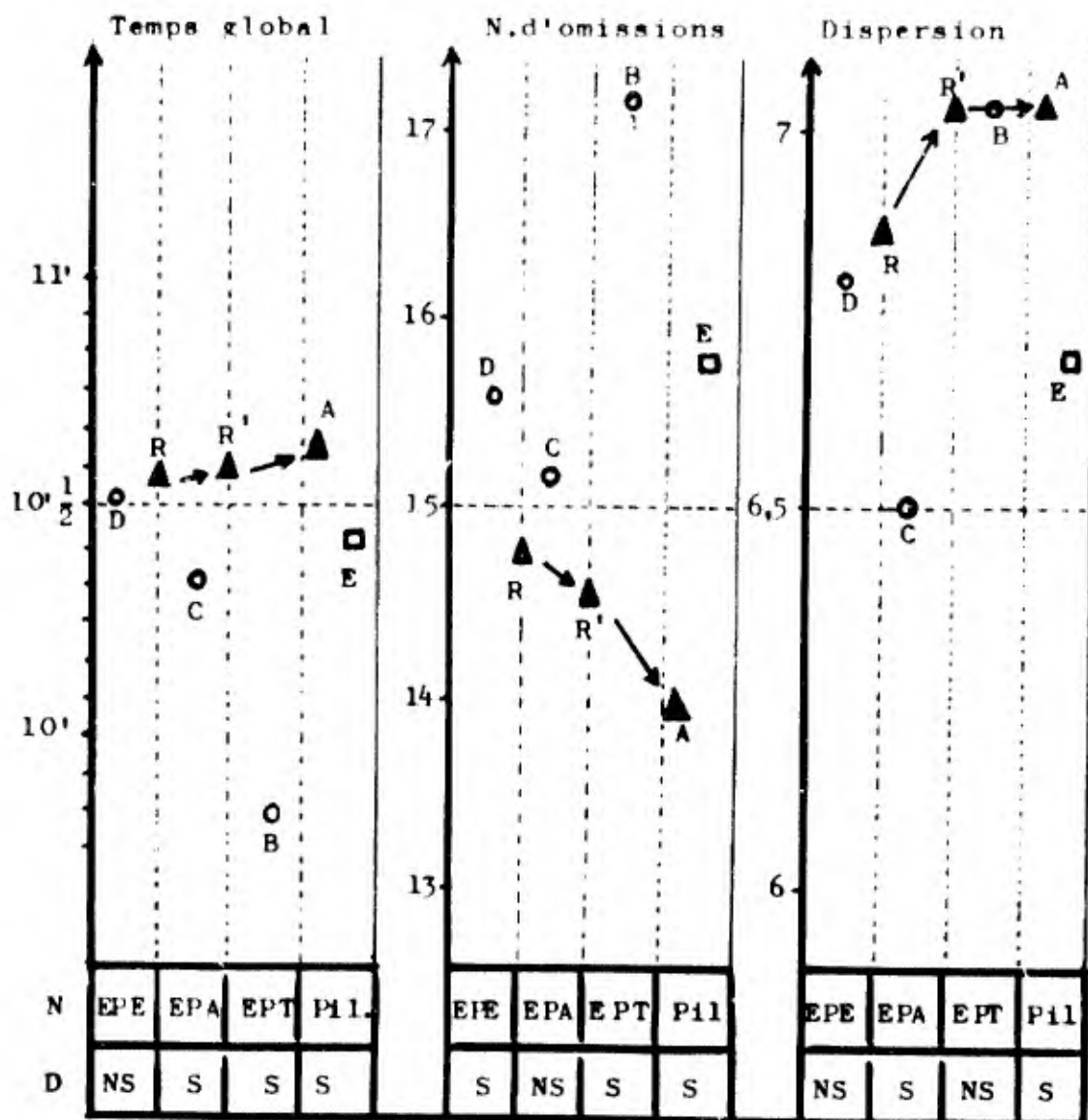

Graphique montrant comment évoluent, pour les 3 facteurs importants du Bourdon-Wiersma, les moyennes obtenues par les groupes de sujets qui réussissent et qui échouent, à chaque niveau de l'entraînement.

Légende: N = niveau de l'entraînement: EPE = Ecole de Pilotage Elementaire; EPA = Ecole de Pilotage Avancé; EPT = Ecole de Pilotage de Transition; Pil. = sujets obtenant finalement le brevet de pilote.

D = différence; indique si la différence entre les moyennes du groupe de sujets qui échouent et du groupe de sujets qui réussissent est significative.

o = sujets qui échouent; ▲ = sujets qui réussissent.

◻ = ensemble des sujets qui échouent.

CONCLUSIONS

Elles sont de deux ordres.

a) En ce qui concerne le test de Bourdon-Wiersma :

- Les moyennes obtenues pour les sujets belges de 18 à 25 ans ne sont pas comparables à celles obtenues chez les sujets néerlandais de 18 à 30 ans en ce qui concerne le nombre des erreurs et la dispersion maximale des temps par ligne. Elles le sont pour le temps global de l'épreuve et le nombre d'omissions. Il y a donc lieu d'adopter pour la population belge les nouvelles valeurs moyennes comme norme.

- Le système de pénalisation et de bonification doit être revu en ce qui concerne le temps global. Nous verrions volontiers une bonification pour le sujet qui se situe à la moyenne et une pénalisation pour celui qui s'en écarte. Les limites doivent encore être calculées.

- D'après les calculs sur notre population il n'y a pas d'intérêt à conserver le facteur "nombre d'erreurs" mais il n'est pas impossible que sur des groupes plus importants une différence apparaisse.

Nous pouvons comprendre maintenant pourquoi le score global tel qu'il est calculé selon la méthode de Van Wulfften-Palthe n'est pas discriminatif. Les sujets devenant pilotes sont pénalisés en ce qui concerne la dispersion maximale des temps par ligne, et les sujets qui échouent ont des bonifications pour des vitesses courtes.

b) En ce qui concerne l'attention chez les candidats pilotes :

- L'attention joue indiscutablement un rôle chez le candidat élève pilote, sous la forme d'une plus grande précision pour une vitesse d'exécution moyenne. On aurait tendance à croire que le meilleur sujet serait celui qui en un temps le plus court commet le moins d'omissions. C'est sans doute un excellent sujet mais cela ne veut pas dire qu'il soit un bon candidat pilote. Nos calculs montrent qu'un bon candidat pilote est celui qui commet le moins d'omissions en un temps moyen.

- Le Bourdon-Wiersma met cette disposition en évidence en mesurant une plus grande efficacité chez les brevetés. L'efficacité mesurée par le Bourdon-Wiersma n'est pas une plus grande quantité de bon travail par unité de temps mais un plus petit nombre d'oublis de signes pour un travail donné. Elle est donc d'une manière quasi idéale l'expression même d'une bonne attitude d'attente et d'observation en vue d'une action.

- Il est intéressant de noter que les sujets déclarés inaptes médicalement à l'entrée ont un nombre moyen d'omissions plus élevé. Comme si les infirmités et affections médicales dont ils souffraient avaient une répercussion sur l'attention.

BIBLIOGRAPHIE

- (1) BRAMS D., De psychotechnische selectie van de kandidaat leerling piloot. Verhandeling voorgelegd tot het bekomen van de titel van licentiaat in de sociale en militaire wetenschappen, Koninklijke Militaire School, Brussel, 1966, 76 pp.
- (2) EVRARD E., Essai d'application du test de Bourdon-Wiersma dans la détermination de l'aptitude au vol des aviateurs, Méd. Aéronaut., 1957, 12 (1), pp 69-79.
- (3) VAN WULFFTEN-PALTHE P.M., Medical Tests for detecting latent epilepsy and fluctuations in the level of consciousness. Collected papers on Aviation Medecine, Butterworths Scientific Publications, London, 1955, pp 31-40.
- (4) " " " " " , The Stipple Test : a follow-up study. Aeromedica Acta, 1956/57, V, pp 327-346.
- (5) " " " " " , Lotgevallen van 840 militaire leerling-vliegers mede in verband met de Bourdonproef. Aeromedica Acta, 1958, VI, pp 195-212.

Dr Paul Lievens
46 Bd Brand Whitlock
BRUXELLES 4

BEHAVIOUR OF PULMONARY VENTILATION AND ALVEOLAR GASES
TENSIONS IN ATHLETES, BEFORE, DURING, AND AFTER A
FIVE WEEKS STAY AT THE ALTITUDE OF 2250 m

by

Col Prof. A.Scano and Lt Col Dr G.Meineri

Italian Air Force,
Aerospace Medical Center - Rome

Summary

A survey of existing literature put into evidence that in most investigators' opinion, a satisfactory adaptation can be achieved - if not an absolute acclimatization - through a more or less protracted, and uninterrupted stay at altitude.

Authors' scope was to ascertain the actual measure of this phenomenon, as well as of its limitations. They investigated it through a longitudinal analysis of some respiratory parameters, at sea level, and at 2300 and 5500 m simulated altitude: pulmonary ventilation, alveolar respiratory gases tensions at rest. The results were:

- 1) sea level: $\dot{V}_{BTPS} = 6093 \pm 1981$ ml; $P_{A_{O_2}} = 107,2 \pm 4,8$ torr;
 $P_{A_{CO_2}} = 38,9 \pm 3,2$ torr.
- 2) 2300 m : $\dot{V}_{BTPS} = 5805 \pm 1840$ ml; $P_{A_{O_2}} = 68,9 \pm 5,0$ torr;
 $P_{A_{CO_2}} = 37,3 \pm 4,0$ torr.
- 3) 5500 m : $\dot{V}_{BTPS} = 7409 \pm 2333$ ml; $P_{A_{O_2}} = 39,8 \pm 3,5$ torr;
 $P_{A_{CO_2}} = 27,0 \pm 2,3$ torr.

Soon after this control, the subjects were transported by aircraft to Mexico City. In this place, the same data were recorded at close intervals, during the whole period of stay.

Recorded values were grouped into six periods, each one of six days. No significant changes were detected in the course of this 5 weeks period of stay at altitude, except for a moderate, but constant, increase of alveolar oxygen tension

uring the first 25 days.

Indeed, mean values referred to successive six-days periods, failed to put into evidence any significant difference as compared with the average value of the acclimatization period as a whole ($\dot{V}_{BTPS} = 10,500$ ml; $P_{A_{O_2}} = 79$ torr; $P_{A_{CO_2}} = 32$ torr).

Such values, however, are significantly different from the values recorded at 2300 m simulated altitude. This fact witnesses a comparatively pronounced, and more stable, condition of adaptation in comparison to the same values recorded at simulated altitude.

Control recordings were executed within 48 hrs after return to sea level. In this occasion, pulmonary ventilation was higher than before the adaptation period.

The results of these experiments were compared with similar values, recorded in surely acclimatized people.

ITALIAN AIR FORCE
Aerospace Medical Center - Rome
Director: Col. Prof. A. SCANO, I.A.F., M.C.

BEHAVIOUR OF PULMONARY VENTILATION AND ALVEOLAR GASES TENSIONS IN ATHLETES, BEFORE, DURING, AND AFTER A FIVE WEEKS STAY AT THE ALTITUDE OF 2250 m

Col. Prof. A. SCANO, IAF, MC

Lt.Col.Dr. G. MEINERI, IAF, MC

Introduction

A renewed, great interest of scientists has been aroused by some topics of aerospace medicine, i.e. man's adaptation, and acclimatization to altitude, and some peculiar effects of hypoxia. This is due to some recently proposed applications of hypoxia, and, mainly, to the fact that the XIX Olympic Games will take place at 2250 m above sea level.

In particular, we refer to the application -- proposed by L.E.Lamb (1965) -- of moderate hypoxia, as a means of counteracting circulatory deconditioning in protracted space flights. We refer also to a similar proposal by L. Pereira Da Costa (1966), intended to improve physical performance in tropical climates, and, concerning adaptation to altitude, to several physiological, and pharmacological means, suggested in order to make adaptation earlier, and more complete, such as the exposition to low temperature, inhibition of carbonic anhydrase, substances derived from blood serum, enzymes, etc.

Generally speaking, these investigations, and proposals, are based on the assumption of "crossed adaptation", obtained through a stress situation, apt to elicit some effects, similar to those, which one wishes to provoke in his subjects.

Therefore, we think that also the participants in a meeting dedicated to human factors of aerial warfare, may be concerned with an investigation, carried out on an outstandingly homogeneous and controlled group of athletes, during a period of adaptation to the altitude of 2250 m, at Mexico City.

In our exposition, we shall use the word "adaptation", meaning all those physiological changes, due to altitude,

which generally occur after a few weeks, are not accompanied by any apparent anatomical changes, except for hemopoietic field, grant a better tolerance to altitude, and regress in a few days, after returning to sea level. On the other hand, acclimatization is defined as a stable anatomic and functional condition, achieved only with a very extended sojourn at altitude. Such a condition is peculiar of the natives of high mountains and is, most probably, backed by some inherited characteristics, that secure a better, actual and permanent tolerance to hypoxia.

Thus, in one sense, the discussion is still open -- from a conceptual standpoint -- whether it is advisable to submit athletes to a few weeks adaptation at altitude, in order to improve their performance. From a practical point, however, contributions, reported in past, and recent literature, (see references) witness a marked improvement in tolerance, achieved through more or less prolonged periods at altitude, even if discontinuous. Respiratory function, as it is well known, is of primary interest. That is why it was accurately investigated, both at rest and during strenuous exercise, in the course of the research, carried out at Mexico City, in Autumn 1966, on Italian athletes. This investigation was executed by the Aerospace Medical Research Center of the Italian Air Force, Rome, Italy, in collaboration with CONI (Italian National Olympic Committee).

Experimental Method

We are reporting, in this paper, only that portion of our research, which concerns the behaviour of pulmonary ventilation and O_2 and CO_2 alveolar tensions, recorded in control conditions, and at intervals during the adaptation period. 19 young, healthy subjects, aged 18-22, two of female sex, were transported by plane to Mexico City. All of them were athletes, of different specialties, in a very good form. 11 subjects stayed at Mexico City 36 days, while the remaining 8 remained there 20 days. For the purpose of our work, both groups were considered as a whole. Their sojourn at 2250 m was uninterrupted. During the days immediately preceding their stay, they were sub-

mitted to a general physic examination, to the determination of pulmonary ventilation, and of alveolar gases composition, as well as to some other functional tests.

The recordings were made in the morning, at rest -- not in basal conditions however -- according to the following succession of experimental conditions: 1) at sea level; 2) at 2300 m (580 torr) simulated altitude; 3) at 5500 m (380 torr) simulated altitude. Simulated ascents were conducted in a low-pressure chamber. Ascension speed was about 200 m/min. Two 30 min halts were effected at 2300 and 5500 m. Simulated ascent to 2300 m was aimed to obtaining data, directly comparable with the values to be recorded at Mexico City. 5500 m data were recorded with the aim of determining the degree of tolerance to comparatively severe hypoxic hypoxia, following a technique tested since long in our laboratory (Scano and Coll. 1956).

Subjects were breathing room air through a mouth-piece. Pulmonary ventilation was recorded with a precision gas-meter. Gas samples were collected, for two minutes, by means of a modified Rahn's apparatus, that enables one to collect terminal expiratory fractions from any number of respiratory cycles. Ventilation recordings, and gas-samplings, were carried on after a suitable stabilization period. The same operations were repeated, in the low pressure chamber, after the subjects had been allowed to adjust to hypoxia for not less than 15 min. Alveolar air, collected in mercury gas samplers, were analyzed with Haldane-Margaria gas analyzer (chemical-volumetric method).

The same tests were repeated again, in the same manner, within 48 hrs after the return from Mexico. The same recordings were carried out during the stay at Mexico City, in the morning hours, at rest, but not in basal conditions. During this period, each subject was repeatedly submitted to the aforementioned experiments not at regular intervals, but, in any case, not less than twice a week. Recorded values were divided into six groups -- each referring to a successive establishment of an adaptive condition.

Experimental Results and Considerations

Mean values and standard deviations of recorded values are reported in the following tables (Tab. I and II). We deemed it convenient to calculate, and tabulate, also alveolar respiratory ratio (R_{alv}), that, by the way, is a

suitable metabolic index, particularly in hypoxic conditions. From the tables, one can draw the following conclusions: pulmonary ventilation (at BTPS), as recorded before and after the stay at altitude (in all of the three experimental conditions: sea-level, 2300 and 5500 m in low-pressure chamber), was constantly and significantly increased after the end of the experiment.

Ventilatory increase was:

- 1) sea-level: + 25.6 per cent ($p < 0.02$)
- 2) 2300 m: + 18.8 per cent ($p < 0.10$; this value is at the limits of significance)
- 3) 5500 m: + 24.6 per cent ($p < 0.05$ per cent)/

The observations are thus confirmed of other investigators, and give evidence in favour of a persistent, higher excitability of respiratory centres lasting some days, and, in any case, of a higher level of respiratory activity connected with an acidotic condition, due to a more active elimination of alkalis through kidneys, in those subjects, who have stayed for a sufficiently protracted period at altitude.

This phenomenon involves a greater basal ventilation, and a more satisfactory adjustment to hypoxia.

As far as pulmonary ventilation, recorded at Mexico City, is concerned, we failed to obtain evidence of any significant difference among the successive six-days intervals.

Indeed, mean values of those six periods do not differ noticeably from mean value, comprehensive of the whole sojourn at altitude (1st - 36th day), which was 10,502 ml.

Mean ventilation, recorded at Mexico City, is in any case, definitely higher if compared with corresponding values at 2300 m simulated altitude. In fact, it is higher than the values recorded both before and after the experimental period, in any of the three considered conditions. In fact, values at sea level, and at 5500 m, are practically unchanged. Only at 2300 m, an insignificant increase (less than 2 per cent) was put into evidence after the stay at altitude.

In any case, if one compares $P_{A_{O_2}}$ mean values, recorded at Mexico (78.6 torr) with the corresponding values recorded during simulated ascent at 2300 m (respectively 68.9 torr before, and 70.4 torr after the experimental period), one can see an increase in both cases (respectively 14.0 and 11.6 per cent).

In a similar way, P_{ACO_2} values, although less regularly, follow the trend of P_{AO_2} . Therefore, they do not show any relevant changes, while they are definitely smaller (32 torr as compared with 37 torr = percentual difference - 13) in gas samples collected at Mexico City. Also the values of R_{alv} do not show any significant changes.

Furthermore, values recorded at Mexico City were compared with the same data recorded in two sedentary men, living at Mexico City, that is to say $\dot{V}_{BTPS} = 14,735$, $P_{AO_2} = 86.7$ torr, $P_{ACO_2} = 26.6$ torr.

One may lay emphasis on the fact that one of the two examined subjects was affected by a certain degree of pulmonary emphysema. Thus ventilation values recorded in the other subject alone -- whose respiratory conditions were normal -- have to be regarded as more representative. Indeed, there is almost no difference between this value ($\dot{V}_{BTPS} 10,621$) and mean pulmonary ventilation of our subjects ($\dot{V}_{BTPS} 10,502$).

The fact ought not to be disregarded, however, that alveolar oxygen tension is lower in our subjects than in those two resident men.

The same comparison could be extended to De Micheli's (1960) much larger and significant statistical investigation. Pulmonary ventilations of populations studied by this scientist was $8,710 \pm 1800$ ml, while it was higher than 10 litres in our subjects. On the other hand, alveolar gas tensions in De Micheli's subjects were: $P_{AO_2} 81.08 \pm 9.78$ torr, $P_{ACO_2} 31.81 \pm 3.11$ torr.

Since De Micheli's group, and the two resident men we also examined, is formed by surely acclimatized people, we suggest that our athletes, in the considered period, have undergone an apparent adaptation, which cannot however be defined as an actual acclimatization process.

Such adaptation, at least from a respiratory standpoint, seems to occur in a comparatively short length of time: very few days. Later, its evolution will be extremely slow, if we wish to attach any significance to the slight, but progressive increase of P_{AO_2} , recorded from the 1st to the 24th day (77.8, 78.1, 79.0, 79.2 torr).

In order to complete the study of our data, they were compared with the data previously obtained in our laboratory on 35 pilots, at the barometric pressure of 380

torr, with a strictly similar method. We found a complete agreement of results. This fact denotes the normality of respiratory response to barometric low pressure of our 19 athletes.

Our measurements are lacking of data referring to respiratory frequency. These would have enabled us, together with other available data, to calculate respiratory dead space, and then alveolar ventilation.

In fact, the slight disagreement between pulmonary ventilation trend, and that of O_2 and CO_2 alveolar tensions, could be dependent on some variations of alveolar ventilation, not perfectly correspondent to the variations of pulmonary ventilation, other than on some factors concerning blood and tissues.

However, since tidal volumes were available, recorded in the same subjects in comparable conditions (sitting on bicycle-ergometer before the execution of maximum O_2 consumption test) we calculated \dot{V}_T mean values, reported in table 3. The increase is apparent of respiratory acts volume in Mexico City. This suggest that a relative increase of alveolar ventilation does exist. Successive measurements show that this phenomenon, which improves ventilatory performance, is evident already in the first days of sojourn at altitude, but does not undergo any appreciable change in the following month. It results also from De Micheli's data that tidal volume is, on the average, 23 per cent higher than theoretic value; and that its increase is accompanied by a progressive elevation of PA_{O_2} .

In conclusion, one might say that ventilatory adaptation to altitude occurs at a very early stage, but it seems to develop extremely slowly. After a 5 weeks, we are still not entitled to speak of complete acclimatization. This, if it possibly occurs at length, might require a much more extended period, to be evaluated in several months, or even in years.

A comparison between data recorded at simulated altitude in low-pressure chamber, and those recorded at actual altitude, shows that the former ones provoke only a limited response of the subjects to hypoxia. In fact, at least within time and altitude limits of our research, one fails to obtain a complete manifestation of all the compensatory mechanisms, of which respiratory apparatus is capable.

REFERENCES

- ARMSTRONG H. G.: 'The effect of repeated daily exposures to anoxemia',
J. Aviat. Med., 1938, 9, 92.
- ASAHINI K., IKAI M., OGAWA S., KURODA L.: 'Studio sull'acclimatazione al—
l'altitudine negli atleti giapponesi', Riv. Svizzera Med. Sport., 1966,
14, 280.
- BARCROFT J.: 'The respiratory function of the blood, Pt. I - II', Cambridge,
Univers. Press, 1925.
- BARCROFT J., BINGER C.A., BOCK A.V., DOGGART J.H., FORBES H.S., HARROP G.,
MEAKINS J.C., REDFIELD A.C.: 'Observations upon the effect of high altitude
on the physiological processes of the human body, carried out in the Peru-
vian Andes chiefly at Cerro de Pasco', Phil. Trans. Roy. Soc. London, Sez.
B.211, 1923, 351.
- BINET L., BOCHET M., STRUMZA M.V.: 'L'anoxémie. Ses effets, son traitement.
L'oxygénothérapie', 1939, Masson Ed., Paris.
- DE MICHELI A., VILLACIS E., GUZZY DE LA MORA P., RUBIO ALVAREZ V.: 'Observa-
ciones sobre los valores hemodinámicos y respiratorios obtenidos en sujetos
normales Arch. Inst. Cardiol. México, 1960, 30, 507.
- DRAGAN I., FLOREA T., TUDOR M., BOTEZATU M., HARALAMBIE Gh.: 'Contributions à
l'étude des réactions d'acclimatation des sportifs de performance', Med.
Sport., 1966, 6, 225.
- FARAGLIA L.: 'La resistenza all'anossia studiata con il metodo della ri-re-
spirazione', Riv. Med. Aeron., 1940, 3, 175.
- HALDANE J.S., MEAKINS J.C., PRIESTLEY J.G.: 'The respiratory response to
anoxemia', J. Physiol., 1919, 52, 420.
- HERRERA A.L., VERGARA L.D.: 'La vie sur les haut plateaux', Imp.I.Escalante,
1899.

- HOUSTON C.S.: 'Operation Everest. A study of acclimatization to anoxia',
Nav.Med.Bull., Washington, 1946, 46, 1783.
- HURTADO A.: 'Animals in high altitudes: resident man', in Dill D.B.:
Handbook of Physiology, Sect.4: Adaptation to the environment, Ed.Am.
Physiol. Soc., Washington, 1964 (bibliografia)
- JOURDANET D.: 'Influence de la pression de l'air sur la vie de l'homme',
Ed.Masson, Paris, 1875.
- LOMONACO T., SCANO A. LALLI G.: 'Medicina Aeronautica ed Elementi di Me-
dicina Spaziale', vol.1^o, Regionale Editrice, Roma, 1959 (bibliografia)
- LUFT U.C.: 'Die Hohenanpassung', Ergeb.N.d.Physiol., 1941,44,256.
- MARGARIA R., CERRETELLI P., BORDONI U.: The regulation of pulmonary venti-
lation in acclimatization to altitude, Rev.Méd.Aéron., 1961, 1, 112.
- MIESCHER J.: 'Ueber die Beziehungen zwischen Meershohe und Beschaffenheit
des Blutes', Korresp. Bl. schweiz. Aerz., 1893, 23, 809.
- MONGE C.: 'La enfermedad de los Andes', Lima, Fac. de Med., 1928.
- MONGE C.: 'Acclimatación en los Andes', Lima, Fac. de Med., 1960.
- PUGH L. G.C.E.: 'Man at high altitude (Studies carried out in the Himalaya)'
The Scientific Basis of Medicine Annual Review, Univ. London, Atblow Press,
1964.
- RICCIONI B.: 'Una esperienza di acclimatazione e allenamento a 2200 metri
di quota', C.O.N.I., Roma, 1966.
- SCANO A., MEINER G., ROSSANIGO F., TAGLIAMONTE B.: 'Comportamento di alcune
grandezze respiratorie nell'uomo alle pressioni barometriche di 760, 526
e 379 mm Hg', Riv. Med. Aeron., 1956, 19, 595.
- VENERANDO A., DAL MONTE A., SEVERINI U.: 'Esperienze sugli adattamenti alla
media altitudine di soggetti allenati allo sport del ciclismo partecipanti
alla settimana preolimpica internazionale di Città del Messico' (ott.1965)
Med. Sport., 1966, 6; 444.
- WYSS V.: 'Lo sport a media altitudine', Med. Sport., 1966, 6, 235.

T A B L E I

MEAN AND STANDARD DEVIATION OF PULMONARY VENTILATION, RESPIRATORY GASES ALVEOLAR TENSION AND ALVEOLAR RESPIRATORY RATIO. THE VALUES WERE RECORDED AT SEA LEVEL AND AT THE SIMULATED ALTITUDES OF m 2300 and 5500, BEFORE AND AFTER THE STAY IN MEXICO CITY, AT m 2250 ALTITUDE.

AT SEA LEVEL

	Before the experiment			After the experiment		
	Subjects (number)	\bar{x}	s	Subjects (number)	\bar{x}	s
V_{BTPS}	(15)	6093	\pm 1981	(19)	7653	\pm 1431
$P_{A_{O_2}}$	(15)	107,2	\pm 4,8	(19)	107,8	\pm 5,1
$P_{A_{CO_2}}$	(15)	38,9	\pm 3,2	(19)	37,7	\pm 3,2
R_{alv}	(15)	0,90	\pm 0,11	(19)	0,89	\pm 0,09

AT m 2300 SIMULATED ALTITUDE

V_{BTPS}	(14)	5805	\pm 1840	(16)	6889	\pm 1411
$P_{A_{O_2}}$	(14)	68,9	\pm 5,0	(16)	70,4	\pm 3,6
$P_{A_{CO_2}}$	(14)	37,3	\pm 4,0	(16)	37,0	\pm 2,9'
R_{alv}	(14)	0,87	\pm 0,06	(16)	0,91	\pm 0,12

AT m 5500 SIMULATED ALTITUDE

V_{BTPS}	(13)	7409	\pm 2333	(16)	9232	\pm 1810
$P_{A_{O_2}}$	(14)	39,8	\pm 3,5	(16)	39,1	\pm 2,1
$P_{A_{CO_2}}$	(14)	27,0	\pm 2,3	(16)	29,6	\pm 2,2
R_{alv}	(14)	0,89	\pm 0,08	(16)	0,96	\pm 0,08

TABLE II

Mean and standard deviation of pulmonary ventilation, respiratory gases alveolar tension and alveolar respiratory ratio. The values are divided according to days groups of stay in Mexico City, at m.2250 altitude.

DAYS	V_{BTPS}		$P_{A_{O_2}}$		$P_{A_{CO_2}}$		$R_{alv.}$	
	Subjects (number)	\bar{x} s	Subjects (number)	\bar{x} s	Subjects (number)	\bar{x} s	Subjects (number)	\bar{x} s
I-VI	(13)	10180 ± 2771	(15)	77,8 ± 3,6	(15)	31,6 ± 2,2	(15)	0,88 ± 0,10
VII-XII	(15)	10110 ± 2422	(15)	78,1 ± 4,7	(15)	30,0 ± 4,7	(15)	0,82 ± 0,06
XIII-XVIII	(10)	12124 ± 3854	(10)	79,0 ± 5,5	(10)	32,8 ± 3,7	(10)	0,95 ± 0,10
XIX-XXIV	(19)	10211 ± 1790	(19)	79,2 ± 2,8	(19)	31,4 ± 2,2	(19)	0,90 ± 0,06
XXV-XXX	(11)	11374 ± 3705	(10)	79,1 ± 4,3	(10)	31,2 ± 2,8	(10)	0,92 ± 0,10
XXXI-XXXVI	(10)	10622 ± 1827	(10)	78,2 ± 3,5	(10)	33,6 ± 2,4	(10)	0,95 ± 0,08

TABLE III

Tidal volumes (V_T) BTPS before, during and after the stay of the athletes in Mexico City.

	I	II	III	IV	V	VI	VII
Athletes	R_1	2-3	5-8	11-14	18-20	32-35	R_2
Boxers	895		870	900	870	805	566
Swimmers	790	1240	1140		1080		900
Cyclists	1060		1320	1500	1240	1250	820
Canoeists	920		1430	1160	1170	1570	990
Mean	916,25	1240,00	1190,00	1186,67	1090,00	1208,33	819,00

NOTE: R_1 and R_2 = values recorded in Rome, before the departure for Mexico City, and after the return in Italy. In the same line the days of their stay in Mexico City are reported.

BLANK PAGE

A THERMAL MODEL FOR RETINAL DAMAGE INDUCED
BY PULSED LASERS*

by

Lt Commander Jude R. Hayes, MC, United States Navy

and

Myron L. Wolbarsht, Ph.D.

*From the Bureau of Medicine and Surgery, Navy Department Research Task MR005.04.0014. This research was supported in part by the Naval Air Systems Command, NWER A46-03.124, and the Defense Atomic Support Agency, contract MIPR 535-67. The opinions or assertions contained herein are the private ones of the authors and are not to be construed as official or reflecting the views of the Navy Department or the Naval Service at large. Further reproduction is authorized to satisfy the needs of the U. S. Government.

We would like to thank Dr. Marvin Stein for assistance with the absorption measurements and Dr. H. Spekreijse for much helpful criticism on the manuscript.

SUMMARY

The model of the retina employing the thermal absorption of a slab of the pigment epithelium layer (assumed to be homogeneous) as proposed by Vos has been examined in detail for both long exposure times (for which it was designed) and short exposure times. The model is sufficient to explain the damage from long exposures but not short exposures. We have examined the physical characteristics of the pigment epithelium, particularly with respect to the thermal stability and optical properties of the melanin granules. A new model is proposed which is based on absorption of the incident energy by the one micron diameter pigment granules and thermal conduction from them to nearby essential retinal structures such as the pigment cell membrane and the receptor cell myeloid body and outer segment. This model explains both long and short pulse damage. Such nonlinear effects as ionization from intense electric field gradients, harmonic generation, Brillouin scattering, shock waves, and re-radiation by blackbody emission are shown to make negligible contribution to the initial tissue damage where the lesion is minimal. Shorter event times (10^{-12} seconds) which are possible from mode locked laser operation may require other mechanisms than postulated by this theory.

Introduction

Retinal burns produced by high intensity light sources have been under continual investigation because of the importance of the problem in industrial and military medicine. Lasers are not only a new source of this hazard, but also another tool by which the problem can be investigated. Early workers in the ocular effects of lasers emphasized the phenomenologic aspects and tried to interpret the phenomena by applying theories developed in their own studies with white light. As the different workers attempted to define the thresholds and explain the mechanisms of the damage many inconsistencies have developed and a review of the concepts has become necessary. It is the purpose of this paper to develop a theory specifically applicable to retinal injury caused by lasers. A model has been developed which is based on measured parameters of the eye. As far as possible, it has been used to predict the phenomena in a real eye rather than in a highly simplified mathematical construct of the eye. The work of Ham et al (10) as summarized in this recent paper has provided the groundwork for understanding laser photic injury. This group defined a mild lesion in the rabbit as one being just visible ophthalmoscopically within 5 minutes after exposure to a high energy pulse. The retinal dose which produced a threshold lesion 50% of the time (based on a probit analysis of the data) for a 250 μ s (non-Q-switched) ruby laser pulse was 0.7 joules/cm². They calculated that the temperature increment produced in the pigment epithelium was 50°C for the long pulse and only 5°C for the short pulse. This suggested to them that some non-thermal mechanism was involved in the short pulse lesion. In their own words /Ham et al (10)/: "The thermal concept of retinal injury is inadequate to cope with the biological effects induced in the eye by the high power densities (megawatts/cm²) and short exposure times (5 to 50 ns) produced by giant laser pulses resulting from Q-switching. Electronic excitation and/or ionization from intense electric field gradients are fast processes (10⁻¹⁴ sec) but heat conduction does not extend spatially beyond 0.1 micron from the site of absorption during the time of a giant pulse. Melanin granules in the pigment epithelium and choroid are generally larger than this. Thus, the pigment granules or absorbing sites in the pigment epithelium would reach high temperatures during the early stages of a giant pulse, producing ionization and possibly a plasma which would be opaque to additional incoming photons. A number of processes, including two-quanta excitation, Raman and Brillouin scattering, shock waves, frequency doubling, and re-radiation by black body emission, must be considered as possible methods for dissipating energy before heat conduction has time to play a prominent role."

Current theories of retinal burn are derived from a model formulated by Vos (18) who used the experimental results of Ham's group and concluded that retinal damage was closely related to the computed amount of steam production. However, he also considered that functional damage might occur at lower levels of irradiation (when the tissue reached a temperature of between 45° and 60°C) where the

albumins began to coagulate. Also he suggested that a temperature elevation of a few degrees centigrade might produce temporary lesions if exposure were prolonged by the process of metabolic poisoning. Metabolic poisoning in this case would be the accumulation of waste products accompanying the elevation of temperature. He assumed the radiation was absorbed in a homogeneous disk-shaped portion of the pigment epithelium 10μ thick, whose flat sides corresponded to the size of the image. He further assumed that the retinal image was irradiated with a constant flux which was uniformly and completely absorbed. The shortest exposure time used in his computation was 20 milliseconds. However, this model ignores the actual fine structure of the eye.

Whereas at low powers and long event times Vos' model applies, for short time events such as laser pulses, it is grossly erroneous. This error occurs because the absorption is not evenly distributed in the pigment epithelium but lumped in small granules about 1 micron in diameter. Also, the thermal relaxation time of these granules is shorter than the event time. The refined eyeburn damage calculation of Mayer and Richey (12) applied to a new model based on the ultra-structural data and measured physical properties yields results which are consistent with the hypothesis that the injury is largely thermal. However, attempts to demonstrate and measure non-thermal effects will be technically difficult. It should be pointed out at this time that the direct measurement of the temperature of the pigment epithelium in the intact eye by conduction is not technically possible because of the short event time, small temperature increments, and minute structures. This problem has been considered in detail by Davis (3). Radiometric methods in the intact eye are likewise impossible as will be shown below in the section on reradiation. However, a new theoretical treatment is necessary in order to design experiments to demonstrate and measure which non-thermal processes are significant. As part of this theoretical analysis, the thermal and non-thermal processes have been reviewed.

Methods

The pigment epithelium was isolated from mongrel dog eyes. Purified melanin granules were prepared from the pigment epithelium using Taniguchi's method [Taniguchi (15)]. The pigment cells were osmotically ruptured and the granules separated by centrifugation. A Siemens Elmiskop IA electron microscope was used for transmission and diffraction studies. The measurements of the optical characteristics (absorption, transmission, and scattering properties) of the pigment epithelium and isolated granules were made in a Beckman DK 1A spectral reflectometer. Small fragments of pigment epithelium were mounted on glass slides. Special calibrated marks were used to reduce the size of the aperture. The specific heat of the melanin granules was measured in a Perkin Elmer Differential Scanning Calorimeter after heating the granules to drive off the water. The thermal stability of the melanin granules was tested by placing them on a formvar carbon coated film

mounted on a metal electron microscope grid (200 per inch). The grid was then heated to 350°C on an electrically controlled microscope stage. Granules were maintained under continuous observation through a light microscope while being heated. Following heating the granules were shadowed with platinum and carbon and examined in the electron microscope. None of these procedures revealed any differences between the control and the heated granules.

Structure of the pigment granules

The ultrastructural organization of the vertebrate eye has been described by Porter and Yamada (13). The most highly absorbing structures are the pigment granules. These are small structures and are concentrated in a narrow zone at the margin of the pigment cell and receptor cell (Fig. 1). Since the receptor cell depends on the pigment cell to maintain its functional and structural integrity, our model considers that the local heating effects in the pigment epithelium (specifically in the pigment granules) would cause widespread damage in the retina. Although the pigment granules vary in size and shape (Fig. 2), the granules can, for the sake of simplicity, be considered as amorphous, non-crystalline spheres 1 micron in diameter. In ultra-thin sections the melanin granules are homogeneous in electron density and have no specific electron diffraction pattern.

Optical properties of melanin granules

The optical properties of the individual grains must be inferred from optical studies on intact eyes and dissected pigment epithelium. The spectral transmission of the retinal pigment epithelium of rabbits of various pigmentation was measured by Rose (14), and the transmission varied from 10% to 40% at 694 nm. Similar average values were obtained in rabbits and humans by Geeraets *et al* (9). Our measurements of the absorption, transmission, and scatter of pigment epithelium from a mongrel dog eye are shown in Table 1.

The transmission measurements are similar to those obtained by Geeraets *et al* (9) for a medium pigmented rabbit fundus if you consider that they did not measure scatter. Since the area we measured is not entirely covered with granules (Fig. 3), the data must be corrected in order to arrive at an absorption coefficient for a granule. The projected area of a single layer of the grains was measured to be 55% of the total area. Thus, a layer of pigment a few granules thick is almost completely absorbing at the ruby laser wavelength. Our measurements indicated no significant absorption in any other tissue component. The degree of scatter in the thin pigment epithelium (10 microns) also confirms our earlier studies in which we demonstrated that the coherence of laser radiation is destroyed by scatter in thin layers of tissue (100 microns). The absorption curve for the pigment epithelium is flat and broad as expected (Fig. 4). Based on these measurements, we calculated the absorption coefficients of the pigment granules

in Table 2. Although the absorption coefficient would seem to be quite large, the electron and mass density of the granules is consistent with a high optical density.

Calculation of the energy absorbed by a single melanin granule

We shall assume that the incident energy is completely and uniformly absorbed by our 1 micron ideal granule. This is the worst case and even if the assumption is in error, the relative values between long and short pulse radiation will remain constant. Although because of scatter the granule will probably not be struck by completely parallel light, the initial calculation of the absorbed energy will assume that this is the case. The energy absorbed using the energy densities of the mild lesions in the short and long pulse is given by

$$E_{\text{abs}} = A_g E/A \quad (1),$$

where A_g is the projected area of a 1 micron sphere, $7.8 \times 10^{-9} \text{cm}^2$ and E/A is the incident energy per unit area, .7 and .07 joules/cm² for the long and short pulses respectively. The absorbed energy is then 5.5×10^{-9} joules (29 cal/cm³) for the long pulse and 5.5×10^{-10} joules (2.9 cal/cm³) for the short pulse irradiation.

Thermal properties of melanin granules

Knowledge of the thermal properties of the granules is necessary to calculate the temperature increment caused by the absorption of the laser energy. The specific heat of the melanin granules harvested from a group of mongrel dogs was found to be 0.61 cal/g°C. The granules were incompletely sedimented in a sucrose density gradient with a maximum of 1.35 g/cm³. Higher specific gravity solutions were not used as the untreated granules were unstable in cesium chloride solutions. For our calculations, we shall assume that the granule has the thermal properties of water. The heat capacity C of a granule one micron in diameter would be $.51 \times 10^{-12}$ cal/°C. The thermal relaxation time of the granule is given by

$$\widetilde{T}_h = (\rho S/k)L^2 \quad (2),$$

where ρ is the mass density, 1 g/cm³; S , the specific heat, 1 cal/g°C; k , the thermal conductivity 1.5×10^{-3} cal/sec²°C cm; and L is the characteristic dimension for energy deposition, 10^{-4} cm in a granule. It should be noted that the expression in the parenthesis is the inverse of the thermal diffusivity. The relaxation time using these values is 6×10^{-6} sec.

Calculation of the temperature increment in the melanin granules

Since thermal relaxation would occur in the long pulse irradiation where the event time, T , is 250×10^{-6} sec, the fraction of the absorbed energy available for heating, F , is given by

$$F = (\tilde{T}_h/\tilde{T}_e) \left\{ 1 - (\exp + \sqrt{\tilde{T}_e/\tilde{T}_h}) \right\} \quad (3)$$

For the long pulse irradiation this is .024 and for the short, it is 1. In other words, given equal doses, 40 times the energy is available for heating in the short pulse irradiation. The temperature increment of the granule is given by

$$\Delta T = F E_{\text{abs}}/C \quad (4)$$

where F is the fraction available for heating, E, the absorbed energy and C, the heat capacity. The temperature increment would be 212°C for the short pulse dose threshold and 53°C for the long pulse threshold dose. From this it is evident that if there were a linear relationship between temperature increment and damage, the Q-switched dose should be about three times more damaging than the non-Q-switched dose, even though it has only one tenth the energy. We have assumed that the long pulse is a single square wave. However, the long pulse is really made up of a series of a hundred or so pulses of about 1 microsecond in duration. Thus even more energy than calculated would be available for the long pulse. This tends to make the doses more comparable.

Thermal stability of melanin granules

Since the structure of the granules was not observed to be affected by these levels of irradiation, a quick disproof of our hypothesis would be to demonstrate that the granules are thermally unstable at the temperatures produced by these doses. The granules were heated to 350°C. The heated granules were identical to the control preparation, as shown in Fig. 2. Disrupted granules were rarely seen in either preparation. The conclusions that can be drawn are that the destruction of the granules cannot be used as a temperature indicator of damage if the in vitro experiment applies to the intact retina.

Calculation of temperature peaks as a function of distance from the melanin granules

Since the granules are not apparently affected by heating, the damage to adjacent structures occurring by heat transfer should be examined. For the doses in question what are the temperature peaks at various distances from the granule? This may be obtained by evaluating the following equation for various distances [Burkhalter (1)]

$$T_{\text{peak}}(r) = 2 E_{\text{abs}} / \sqrt[3]{r^3 \rho S (2/3 \pi e/3)^{3/2}} \quad (6)$$

wherein E_{abs} is the energy in calories assumed to be absorbed instantaneously at the origin of spherical coordinates; r, the distance from the origin in cm; ρ the density in g/cm³ and S the specific heat in cal/g°C. The evaluation of the equation for distances of interest is given in Table 3.

Since the temperature peak falls off as the cube of the distance from the heat source, the granules must be of the order of microns away from each other in order to conduct significant heat to each other. The distances in the eye from the granule surface to the pigment cell membrane are about .01 micron; to the receptor cell membranes, .01 micron or greater; to adjacent granules, 1 micron; to the receptor cell nucleus, 10 microns; to the ganglion cell layer, 100 microns. The peak temperature increments in Tables 3 and 4 do not consider the thermal relaxation time effect but it can be seen that if a 1 micron granule is heated to 230°C that boiling and the destructive effects of phase change would occur in narrow zone tenths of microns about the granule. This would still involve many significant structures such as the cell membrane, myeloid bodies and the receptor outer segments. The volume occupied by steam and gases produced by this boiling would be larger.

Calculation of the radii of critical temperature spheres

Another calculation of interest is the radius of damage assuming critical temperatures of 55°C, the temperature at which protein denaturation rate proceeds rapidly and 100°C, the boiling point of water in the cells. These temperatures represent increments of approximately 20 and 60°C above ambient in a homotherm. These radii are given by

$$r_{\max}(t) = (2/3\pi e)^{1/2} (2E_{\text{abs}}/\rho ST)^{1/3} \quad (7)$$

wherein r is the radius in cm, E_{abs} in calories, ρ the density in g/cm³, S the specific heat in cal/g°C and T the temperature in °C [Burkhalter (1)]. For the long and short pulse mild lesion doses, the radii are given in Table 4.

Remembering that the calculation assumes that the energy is absorbed instantaneously at the origin of the spherical coordinates, the damage and boiling radii are smaller for the long pulse case. Since the actual condition is radically different for the long pulse case (the energy is being conducted away), these values indicate that boiling, if it occurs, occurs within or immediately next to the granule. However, the heat contribution from adjacent granules and granules surrounding the receptor outer segments would increase the magnitude of the thermal wave and damage radii.

Calculation of the reradiation from heated melanin granule

Although we have considered heat transfer by conduction, reradiation from the heated granules may also be significant. If we assume that our 1 micron granule undergoes a temperature increment of 260°C (the worst case) and if the radiant emittance is 1 and blackbody conditions held, the reradiation is given by

$$W = \int_{\lambda=0}^{\lambda=\infty} W_{\lambda} d\lambda = \sigma T^4 \quad (8)$$

σ is the Stefan Boltzman constant, 5.7×10^{-12} joule $\text{cm}^{-2}\text{sec}^{-1} \text{ } ^\circ\text{K}^4$, and T is the temperature in $^\circ\text{K}$. For T of 600°K , w is $.74$ joule $\text{cm}^{-2}\text{sec}^{-1}$. In other words, reradiation is occurring about 10^{-3} to 10^{-7} times lower than the radiation (or absorption). However, since the function varies as the fourth power of the temperature, reradiation becomes significant in the more severe exposures, but explosive boiling would supervene. In any case, the wavelength of the maximum intensity of the reradiation by the Wien displacement law would be 8 microns for 363°K and 5.5 microns for 522°K . Since tissue water absorbs very heavily in this region, the reradiated energy would be absorbed in a few microns. The time lag in reradiation, coupled with the absorption of it by tissue water, decrease the possibility of successfully monitoring the time temperature profile of the absorbing structures with a radiometric microscope or similar device.

Another damage mechanism which has been proposed is the generation of shock waves by thermal expansion. If we consider a 1 micron thick slab with the thermal properties of water to have undergone various temperature increments in a brief time (10^{-8} seconds), the intensity of the elastic waves attributable to thermal expansion can be approximated by

$$I = \rho vU^2/2 \quad (9)$$

where ρ is the density in g/cm^3 , v the velocity of sound in the medium $1.5 \times 10^5 \text{ cm}/\text{sec}$, and U the particle velocity in cm/sec [Fry and Dunn, (7)]. The latter is calculated by

$$U = \alpha T L/t \quad (10)$$

where α is the linear coefficient of thermal expansion of water, $7 \times 10^{-5}/^\circ\text{C}$, and T is the temperature increment in $^\circ\text{C}$, L is the slab thickness, 10^{-4}cm and t is the event time, 10^{-8} seconds. Also of interest is the acoustic pressure amplitude P which is given by

$$P = (\rho v2I)^{1/2} \quad (11).$$

The values of I and P for the various temperature increments are given in Table 5.

Since the acoustic intensity cavitation threshold of both water and tissues sharply increases with frequency, it is highly unlikely that cavitation will occur. If the energy pulse was harmonically transformed into a mechanical wave, the frequency would be in the 10^8 cps range where the cavitation threshold is estimated to be of the order of thousands of atmospheres [Fry and Dunn (7)]. At lower frequencies such as those which would occur during a similar transformation of the pulse train of a non-Q-spoiled dose, the cavitation thresholds are still of the order of tens of atmospheres. No cavitation was seen in beef muscle during 500 kc irradiation at an intensity of $400 \text{ watts}/\text{cm}^2$

[Esche (6)]. Similarly, a two second long 1 mc pulse at an intensity of 50 atmospheres produced no cavitation in the central nervous system [Dunn (5)]. It is reasonable to expect that high frequency elastic waves will be generated by the laser pulses which produce mild lesions; however, they cannot be used to explain damage below the range of thermal damage. The elastic waves detected by Desvignes, et al (4), were probably of thermal origin. Carome et al (2) irradiated aqueous solutions of Prussian blue (absorption 820 cm^{-1}) at an intensity of 1.6 megawatts/cm² and detected an acoustic signal of 4 atm. .2 microseconds long. Although the intensity would increase as the square of the temperature increment, at the 100°C increment the tissue would already be undergoing the violent destruction associated with the change of phase of tissue water.

The above calculations have assumed the worst case of complete absorption, and lossless transformation. Any other conditions will act to minimize the intensity of acoustic waves.

Comments on other proposed mechanisms of damage production

One of the consequences of high intensity electric fields is free radical formation. Possibly these highly reactive substances could cause a retinal lesion. Since the irradiances under discussion are of the order of 1 megawatt/cm² the peak value of the electric field is given by

$$\bar{E} = (2 \bar{W} \mu/\epsilon)^{1/2} \quad (12)$$

where W is the irradiance in watts/cm², μ the permeability and ϵ the permittivity. The value of μ/ϵ for a vacuum is 376.7 ohms. For an irradiance of 1 megawatt/cm², \bar{E} is about 3×10^4 volts/cm. Since a field strength over 10^{10} volts/cm required to approach that binding the electrons to atoms, ionization is not likely to occur at the doses in question. At higher doses the thermal effects would make any ionization all but undetectable.

Non-linear optical processes are phenomena which affect the propagation of light and which are dependent on higher powers of the electric and magnetic field strengths. The theory of non-linear optics is discussed in detail by Terhune (16). The specific processes which we shall consider are second and third harmonic generation and parametric amplification (Brillouin and/or Raman scatter). The efficiency of harmonic generation where the materials have dissimilar indices of refraction is given in Table 6.

The efficiency of conversion is proportional to the irradiance for the second harmonic and to the square of the irradiance for the third harmonic. The efficiency becomes significant only when there is good matching of the indices of refraction. These conditions occur in a non-linear, i.e., birefringent material, such as the receptor outer

segment, but several facts mitigate against such an occurrence:

1) scatter has largely destroyed the beam coherence so that the phase relations are random, 2) the orientation of the birefringent elements is critical to the efficiency. Even if the process occurred it would not lead to damage unless the intensity of the harmonic was sufficient to produce damage by the thermal mechanism. The pigment epithelium is heavily absorbing at the wavelengths of the second and third harmonics of the ruby laser wavelength, 347 and 231 nanometers. Thus harmonic generation if it occurs to any significant degree would not change the character in the pigment epithelium of the lesion as the basic damage mechanism would be the same.

Stimulated Brillouin scattering has been demonstrated in liquids by Gamire and Townes (8). However, because of the high absorption of the gigacycle acoustic waves generated, the threshold for observation of the effect (30 MW/cm^2) is much higher than the intensities under discussion (1 MW/cm^2). The Raman laser effect cannot be readily discussed for tissues except to assume that the frequencies generated would be within the wide absorption band of the pigment epithelium. Also the structures in which these frequencies were generated would not be damaged unless it be by a thermal mechanism.

Thermal damage mechanisms

The absorbed energy density per incident J/cm^2 is 360 cal/cm^3 . This energy would be dissipated in heating the granule and vaporizing tissue water. The latter is extremely important because of the destructive effects of steam and the pressures accompanying its generation. Approximately 300 cal/cm^3 would be available for vaporization and about .14 g water per g of specimen would be vaporized producing a volume of steam at standard conditions of 1700 cm^3 . This process we call physical amplification in that when it occurs the lesion volume may increase by a factor of 1200 and the lesion diameter by a factor of 10. The steam produced probably condenses but other slowly absorbable gases are produced and a small bubble frequently remains [Hayes et al (11)]. By estimation a 1 micron granule would produce 815 microns^3 of steam per incident J/cm^2 .

Although Vos (18) could relate damage to steam production, it is apparent that insignificant amounts of steam ($33 \mu^3$) would be produced about each granule in long pulse thresholds where the temperature increment is calculated to be 75°C . In the long pulse lesion the most likely damage mechanism is thermal inactivation of the essential structures and functional molecules with secondary biological amplification via the inflammatory response in the eye. This consists of edema produced by altered capillary permeability. It is mediated by histamine-like substances released from heated tissues. The observed lesions are much larger than the calculated retinal image size. Probably both physical and biological amplification occur. The time delay observed in the appearance of the lesions [Vassiliadis et al (17)] is consistent with the

biological response concept. If the lesions were the result of the physical response alone they should appear instantly.

Another factor to be considered is the occurrence of hemorrhage or lesions in the deeper layers of the choroid layer. The distribution and character of the lesions may be modified by the absence of pigment granules over the nucleus of each of the pigment cells in the pigment epithelium (see Fig. 3). Through these windows the full intensity of the beam may strike the (ordinarily shielded) choroidal pigment granules. If there is a blood vessel in the choroid in close proximity to the heated pigment granules, then a hemorrhage will occur.

Conclusion

At present thermal effects which are mediated by the pigment granules appear to be the primary and possibly the only cause of threshold retinal burns. However, the experimental techniques used to demonstrate non-linear, non-thermal effects are readily adaptable to experiments on the retina. Very short pulses (10^{-12} sec) are now available from mode locked lasers. Possibly future experiments with these shorter pulses (and higher peak powers) will show a significant contribution by some non-linear process.

REFERENCES

1. Burkhalter, J. H. Material effects of laser radiation and basic interaction phenomena. Federation Proceedings, Vol. 24, No. 1, Pt. 3, Suppl. 14, 1965, pp. S31 - S34.
2. Carome, E. F.
Clark, N. A.
Moeller, C. E. Generation of acoustic signals in liquids by ruby laser induced thermal stress transients. App. Physics Letters, Vol. 4, No. 6, 1964, pp. 95-97
3. Davis, T. P. In vivo temperature measurements. Acta Ophthalmologica, Suppl. 76, 1963, pp. 41-50.
4. Desvignes, P.
Amar, L.
Bruma, M.
Velghe, M. Sur la generation d'ondes ultra-sonores et formation des bulles dans le vitre d'un oeil humain par irradiation d'impulsion laser. C. R. Acad. Sci. Paris, Vol. 259, 1964, pp. 1588-1591.
5. Dunn, F. Physical mechanisms of the action of intense ultrasound on tissue. Amer. J. of Physical Med., Vol. 37, 1958, pp. 148-151.

6. Esche, R. von Untersuchung der schwingungs-kavitation
in flussigkeiten. Akust. Beih., No. 4,
April 17, 1952, pp. AB208-AB218.
7. Fry, W. J.
Dunn, F. Ultra Sound: Analysis and Experimental
Methods in Biological Research. In
Physical Techniques in Biological Research,
Vol. IV, W. J. Nastuk, ed., Academic Press,
N. Y., 1962, pp. 261-394.
8. Gamire, E.
Townes, C. H. Stimulated Brillouin scattering in
liquids. Appl. Physics Letters, Vol. 5,
No. 4, 1964, pp. 84-86.
9. Geeraets, W. J.
Williams, R. C.
Chan, G.
Ham, W. T., Jr.
Guerry, D., III
Schmidt, F. H. The loss of light energy in retina and
choroid. Acta Ophthal., Vol. 64, 1960,
pp. 606-615.
10. Ham, W. T., Jr.
Williams, R. C.
Mueller, H. A.
Guerry, D., III
Clarke, A. M.
Geeraets, W. J. Effects of laser radiation on the mammali-
an eye. Tran. New York Acad. Sciences,
Series II, Vol. 28, 1966, pp. 517-526.
11. Hayes, J. R.
Fox, J. L.
Stein, M. N. The effects of laser irradiation on the
central nervous system. I. Preliminary
Studies, J. Neuropath. Ex. Neurol.,
Vol. 26, 1967, pp. 250-258.
12. Mayer, H. L.
Richey, F. Eye burn damage calculation for an exo-
atmospheric nuclear event. J. Optical
Soc. America, Vol. 54, 1964. pp. 678-683.
13. Porter, K. R.
Yamada, E. Studies on the endoplasmic reticulum.
V. Its form and differentiation in pig-
ment epithelial cells of the frog retina.
J. Biophy. Biochem. Cytol., Vol. 8, 1960,
pp. 181-205.
14. Rose, H. W. Research study of the production of
retinal burns. Tech. Rep. Defense Atomic
Support Agency, Washington, D. C. DASA-1279.
15. Taniguchi, Y. Ultra structure of pigment granules of
retinal epithelium. I. Cow's eye. Amer. J.
Ophthalmol. Vol. 48, No. 2, 1959, pp.221-230.

16. Terhune, R. W. Non-linear optics. Sold State Design,
Vol. 4, No. 11, 1963, pp. 38-46.

17. Vassiliadis, A. Investigation of retinal damage using a
 Rosan, R. C. Q-switched ruby laser. Technical Rep.
 Peabody, R. R. Air Force Avionics Lab. AF33(615)-3060.
 Zweng, H. C. Wright Patterson Air Force Base, Ohio,
 Honey, R. C. August 1966.

18. Vos, J. J. A theory of retinal burns. Bull. Math.
 Biophy., Vol. 24, 1962, pp. 115-128.

TABLE 1

Optical Characteristics of Pigment Epithelium (Mongrel dog retina)

<u>Wavelength</u>	<u>Transmission</u>	<u>Scatter</u>	<u>Absorption</u>
694 nm (ruby laser)	36	23	64
1060 nm (neodymium)	60	28	40

TABLE 2

Absorption Coefficients of Pigment Granules (Mongrel dog retina)

<u>Absorption length</u>	<u>Absorption coefficient</u>
1 micron	10^4 cm^{-1}
2 microns	$5 \times 10^3 \text{ cm}^{-1}$
3 microns	$3.3 \times 10^3 \text{ cm}^{-1}$

TABLE 3

Temperature Peaks at Different Distances from the Pigment Granule.
Calculated from Equation (6)

<u>r, distance cm</u>	<u>Dose</u>	
	<u>5.5 x 10⁻⁹ joules</u>	<u>5.5 x 10⁻¹⁰ joules</u>
10 ⁻⁴	250°C	25°C
1.1 x 10 ⁻⁴	188	18.8
2 x 10 ⁻⁴	31	3.1
3 x 10 ⁻⁴	9.3	.93
10 ⁻³	.25	.025
10 ⁻²	.00025	.000025

TABLE 4

Radius of Critical Temperature for Various Dose Levels from Equation (7)

<u>Temperature</u>	<u>Dose</u>	
	<u>5.5 x 10⁻⁹ joules</u>	<u>5.5 x 10⁻¹⁰ joules</u>
55°C	2.2 x 10 ⁻⁴ cm	9.9 x 10 ⁻⁵ cm
100°C	1.5 x 10 ⁻⁴ cm	6.9 x 10 ⁻⁵ cm

TABLE 5

Intensity (I) and Pressure (P) of Acoustic Waves for Various Temperature Increments

<u>T</u>	<u>I</u>	<u>P</u>
<u>C</u>	<u>watts/cm²</u>	<u>atm</u>
1	3.7×10^4	.11
10	3.7×10^6	1.1
100	3.7×10^8	11

TABLE 6

Harmonic Generation at Various Levels of Irradiance

<u>Irradiance (Watts/cm²)</u>	<u>Efficiency of conversion in percent</u>	
	<u>second harmonic</u>	<u>third harmonic</u>
10^4	3×10^{-4}	2.5×10^{-13}
10^6	3×10^{-2}	2.5×10^{-9}

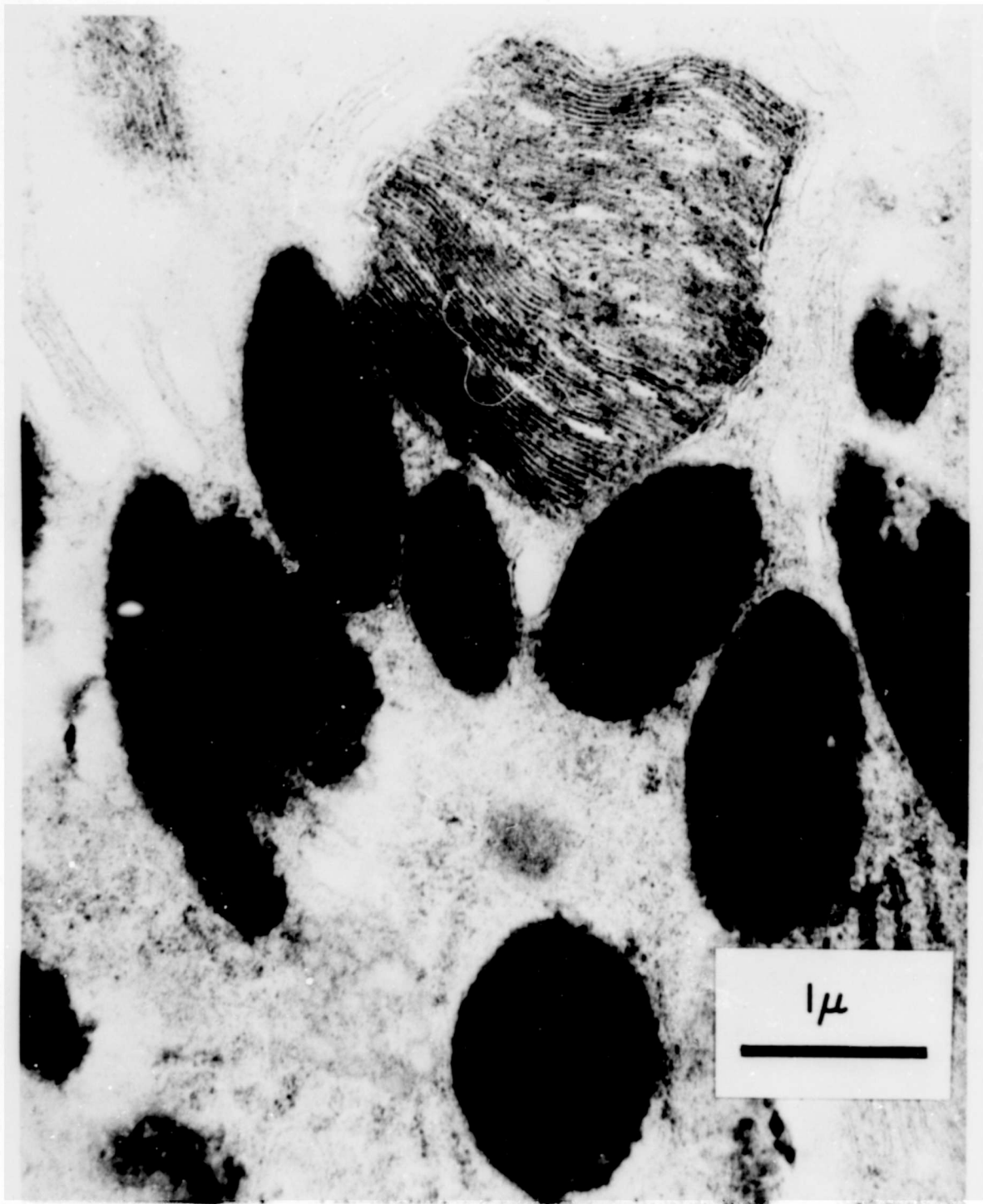

Figure 1. Electromicrograph of dog retina. The lamellar portion of a rod outer segment in oblique section is at the top of the photograph. Closely clustered around it are the pigment granules. Note that many of the pigment granules appear to be separated from the rod outer segment only by the membranes of the receptor cell and the pigment cell.

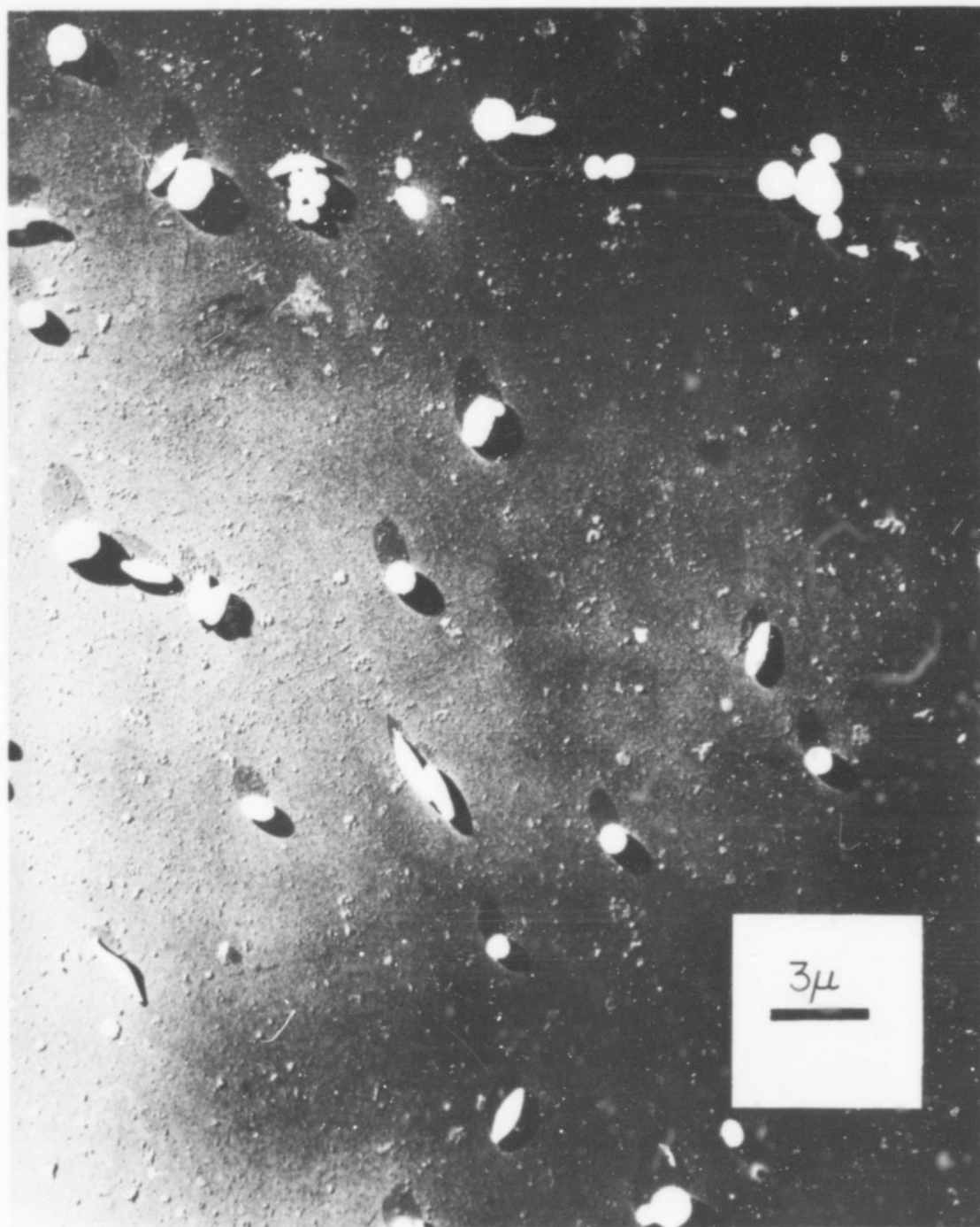

Figure 2. Isolated pigment granules in the pigment epithelium of a dog retina. Double shadowing with platinum and carbon. These pigment granules have been kept at room temperature prior to shadowing. Granules which have been heated to 350°C prior to shadowing showed no significant differences from the granules shown here. See text for further details and discussion.

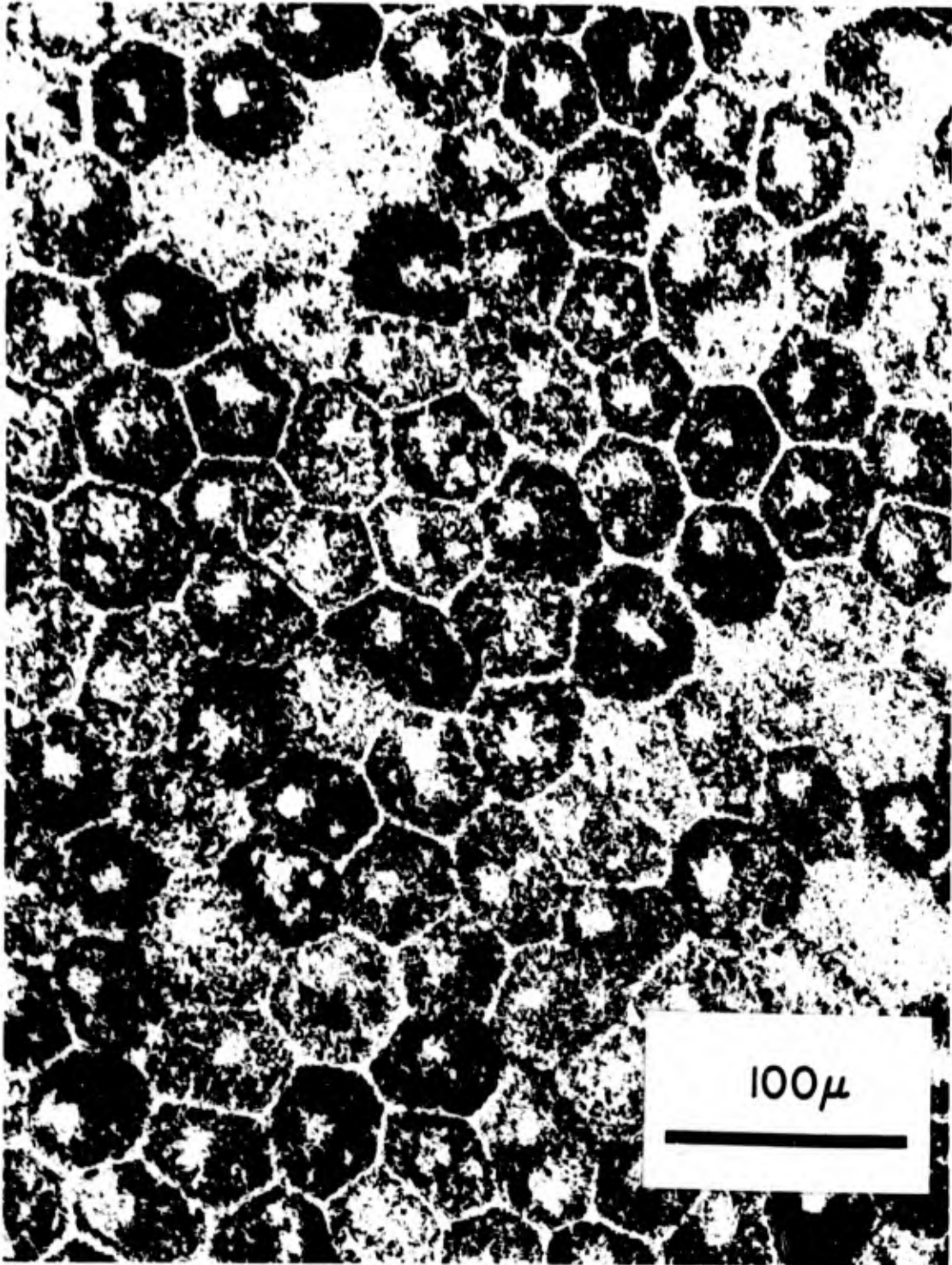

Figure 3. Isolated pigment epithelium of a dog retina. Wet preparation. This photograph has been taken to show the distribution of pigment granules with respect to normally incident light. The light areas in the otherwise heavily pigmented cells represent the position of the nuclei. About 55% of the area is covered with pigment granules. See text for further description of methods.

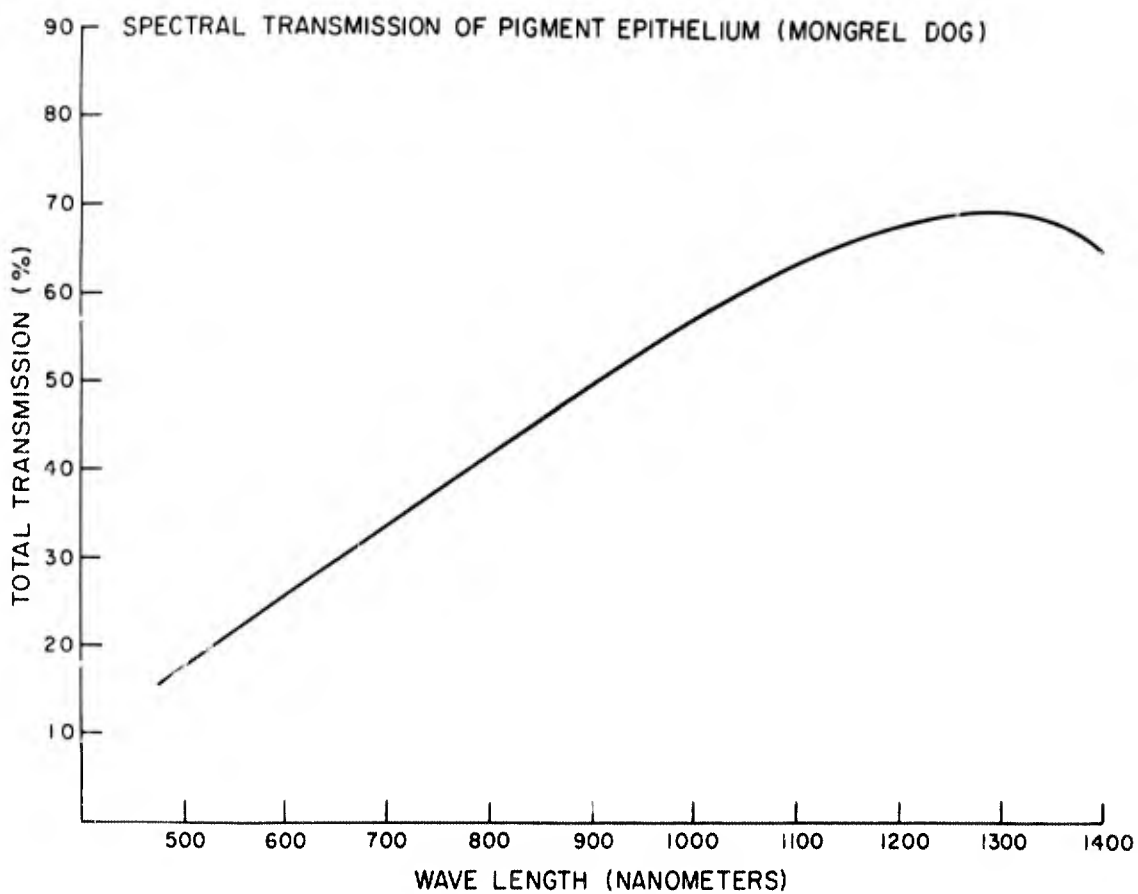

Figure 4. Absorption curve for the pigment epithelium of a dog retina.

BLANK PAGE

MECHANISMS OF INJURY FROM VIBRATION

by

LT D. J. Sass, MC, USNR, LCDR J.R. Hayes, MC, USN
and Capt. D.E. Goldman, MSC, USN

Naval Medical Research Institute
Bethesda, Maryland 20014

Summary

Studies were carried out on anesthetized cats immersed in a transparent water-filled tank and vibrated erect along the longitudinal body axis. Gross examinations were performed on all animals immediately after vibration. Autopsy findings showed similarities to blast injury. Mediastinal emphysema and air embolism were found in cats vibrated erect at relatively low levels of acceleration. At higher levels, mediastinal air dissected downward to inflate the peritoneal cavity and retroperitoneal spaces. The presence of intra-abdominal air was associated with rupture of the liver and tearing of both the portal vein and the inferior vena cava.

Previous investigations in our laboratory on cats vibrated in the supine position in a water immersion tank had shown lung contusion to be the predominant injury. This was attributed to the heart pounding the lungs against the chest wall. The results of the present study when compared with this earlier work, indicate that body position is a critical factor in the mechanism of vibration injury.

The opinions or assertions contained herein are the private ones of the authors and are not to be construed as official or reflecting the views of the Navy Department or the Naval Service at large.

From the Bureau of Medicine and Surgery, Navy Department, Research Task No. MR-005.04.0037. (Supported in part by NASA Contract R-10)

The experiments reported herein were conducted according to the principles enunciated in "Guide for Laboratory Animal Facilities and Care" prepared by the Committee on the Guide for Laboratory Animal Resources NAS-NRC.

Introduction

Previous studies of vibration injury have demonstrated the vulnerability of the respiratory system to intense whole body vibration (1,2). Most of these studies were carried out with the experimental animal supine and the direction of vibration either vertical (G_x) or horizontal (G_y , G_z). The supine position has been used most often because animals are easily restrained supine whereas it is more difficult to support a limp, anesthetized animal erect on a shake table.

Vibration injury in rats in the erect position has been studied by Roman (3). The rats were restrained with cord loops around the shoulders and thighs, which permitted considerable motion of the abdomen in and out of the thoracic cavity during vibration. In addition to the usual injuries to the respiratory system, Roman found injuries to the abdominal organs which were especially severe in animals vibrated with a "maximum effect" frequency. The presence of a range of frequencies within which susceptibility to vibration injuries was greatest was attributed to resonance in the thoracic-abdominal system.

Papé et al (4) vibrated cats supine, totally immersed in water, and found a lower mortality than in cats vibrated supine and restrained with a leather wrap. They found pulmonary and myocardial contusions to be the predominant pathological effects, and abdominal injuries minimal. The protective value of water immersion is due to better abdominal support and the elimination of secondary injuries produced by the slapping of the animal against the restraint.

In the present study cats were subjected to vibration in the erect position. Water immersion was used because of the ease with which an immersed animal could be held erect, and because of the protection water immersion provides against secondary injuries. The purpose of the study was to determine the acute pathological effects and the mechanisms of injury in cats vibrated erect with vertical sinusoidal motion.

Methods

The water immersion system is shown diagrammatically in Figure 1. The apparatus is fabricated almost entirely of transparent lucite, permitting high speed motion picture photography and x-ray cinematography of the subject during vibration. The immersion tank is a 5-1/4" x 24" cylinder mounted upright on the vibration platform, and holds the cat snugly with its forearms secured to a light plastic frame. An endotracheal tube passes through the cover, permitting the cat to breathe room air. A rubber mask stabilizes the head and forms a water tight seal around the head.

The immersion tank is connected by a short flexible coupling to a fixed respiratory exchange tank of similar size. The water level in the respiratory tank is adjusted to heart level so that the average pressure on the chest wall is atmospheric, with an increasingly negative pressure gradient toward the head. The cats spontaneously breathe room air, displacing water from the immersion tank into the respiratory tank upon inspiration and reversing the flow during expiration.

A mechanical damper closes the open end of the respiratory exchange tank. The damper is a piston fitted to a tank and suspended on the water surface by a stiff spring. The spring-mass device functions as a mechanical low-pass filter, freely permitting the relatively low frequency water exchanges associated with respiration, but resisting the water surges between the tanks at the vibration frequency. These water surges are a result of the movement of the abdominal contents in and out of the chest at the vibration frequency. The inertia of the water mass and the damper together limit the rapid fluctuation in chest volume during vibration.

Figure 2 is a photograph of the experimental arrangement. The study used male cats anesthetized with 20 mg/kg intraperitoneal sodium pentobarbital. Each animal was exposed to uninterrupted sinusoidal vibration at one frequency and acceleration. Frequency varied between 3.5 hz and 20 hz, and peak accelerations ranged between 1 G and 15 G. Sixty-two cats were exposed to frequencies and accelerations as shown in Table 1. The duration of the experiments was 30 min for the control group and for those animals exposed up to 4G. All of these animals were living at the completion of the experiments. The exposure times at 8 G and 15 G were varied between 15 sec and 30 min for purposes of studying the time course of injury at these levels. No animal survived more than 3 minutes exposure at 15 G. All animals were autopsied immediately after vibration. Histological examinations were performed on 40 of them. Those animals alive after vibration were sacrificed by intravenous sodium pentobarbital. The trachea was clamped and the heart and lungs removed en bloc. Many of the fresh heart-lung specimens were photographed for comparative purposes.

Results

The results of this study show that the development of injury as a result of intense sinusoidal vibration under the described conditions follows a reproducible pattern and sequence. The pathological effects are related to acceleration and exposure time but not to frequency when comparisons are made on the basis of constant acceleration.

The significant autopsy findings in the experimental animals are the following:

1. airway rupture
2. air embolism
3. pneumoperitoneum
4. pulmonary contusion

Figure 3 outlines the sequence of injury determined from pathological examinations in the 62 experimental cats.

Airway Rupture

Mediastinal emphysema was the most frequent gross finding and occurred to some extent in all animals exposed to 4 G or higher levels. The severity was greatest in the 15 G animals, and was present in this group after exposures as brief as 30 seconds. Mediastinal emphysema resulted from leakage of air from the bronchial tree into the interstitial tissues. Whether this occurred in the alveoli, bronchioles or bronchi is unknown since the lungs from these animals inflated easily and showed no significant leaks under water.

In cats subjected to 15 G vibration for more than 3 minutes, pneumothorax and eventually massive pulmonary collapse were produced. When the lungs of these animals were inflated under water significant air leaks in the bronchi were found beyond the segmental divisions. Whether the airway rupture resulted from either excessive pressure or shear-strain, or both, during vibration is unknown.

Air Embolism

Generalized air embolism was found in approximately one-third of the animals subjected to either 8 G or 15 G vibration. The diagnosis was based on gross observation of foamed blood in the heart and large vessels. Air was found in both veins and arteries in the cerebral vessels, heart, lungs, vena cava and mesenteric vessels. No special procedures were used to detect lesser degrees which were possibly present. The sources of the air were broncho-venous fistulas formed as a result of bronchial rupture.

Pneumoperitoneum

Marked pneumoperitoneum was found in all 15 G animals with exposures of one minute or more, and in over half of the 8 G animals with exposures of more than 10 minutes.

The severity and kinds of abdominal injury were related to the presence or absence of pneumoperitoneum. When pneumoperitoneum was

present, large air bullae were also found in the retroperitoneal spaces, and interstitial air could be traced cephalad along the esophagus into the emphysematous posterior mediastinum. Hemoperitoneum, resulting from tears in the liver parenchyma, was always accompanied by pneumoperitoneum. The liver tears were found along the large branches of the hepatic veins on the diaphragmatic surface and followed the branches of the portal vein in the visceral surface. The vessels of the portal system were engorged and vascular tears were commonly found at the root of the mesentery and in the free edges of the lesser omentum.

In the absence of pneumoperitoneum, abdominal injuries were minimal and limited to passive congestion of the kidneys, liver, and portal system. The degree of congestion in the abdominal organs paralleled congestion in the lungs, and was generally minimal in the 8 G and marked in the 15 G group of animals.

Pneumoperitoneum resulted from air dissecting from the posterior mediastinum along the esophagus and great vessels into the retroperitoneal space, and from there rupturing into the peritoneal cavity. When the peritoneal cavity was inflated, the abdominal organs were displaced by a surrounding air cushion, resulting in loss of restraint. Considerable movement of the abdominal organs relative to one another was then possible during vibration. The liver, the most massive abdominal organ, was torn in the region of its large venous roots, resulting in massive bleeding into the peritoneal cavity.

Pulmonary Contusion

The costophrenic portion of the lung was a constant site of contusion in all animals exposed to 8 G or more. In the 15 G group the area of contusion involved not only the inferior border but extended over the diaphragmatic surfaces of other lobes.

On inspiration this portion of the lung normally dips into the costo-diaphragmatic recess between the lower chest wall and lateral surfaces of the diaphragm near its origins. Contusion in this area during vibration suggests a pinching of the lung, either by the diaphragm moving upward or the chest wall moving inward, or both.

There was no consistent evidence of pulmonary contusions attributable to heart-lung impacts nor were rib markings a very prominent feature. The apical lobes were often atelectatic but when inflated showed little evidence of injury. The degree of pulmonary congestion increased in the direction from the apical lobes to the lung base.

Discussion

Previous investigations in this laboratory were performed on immersed cats vibrated supine with vertical sinusoidal motion (1). The animals were able to tolerate 15 G exposures for durations of 5 to 120 minutes with a mortality of 55%. Pulmonary and myocardial contusions were the predominant pathological effects, and these were attributed to the heart pounding the lungs against the chest wall.

In the present study, by comparison, no animal vibrated in the erect position survived 15 G exposures of more than 3 minutes duration. The autopsy findings of airway rupture, air embolism, massive pneumo and hemoperitoneum which played a prominent role in the present investigation were not found in the earlier work. Furthermore, there was no pathological evidence that heart-lung impact was part of the mechanism of vibration injury in the erect position. The results of the present study when compared with the earlier work indicate that body position is a critical factor in the mechanism of vibration injury.

The pattern of injury in the present series of animals shows some resemblance to the pattern of blast injury, suggesting that similar mechanisms might be involved. In both blast and vibration injury, interstitial emphysema, air embolism, and pulmonary contusions of the costophrenic portion are typical features (5). The determinant of injury due to air blast is the acceleration imparted to the chest wall by the blast wave (6). In cats undergoing vibration, high speed motion picture films and x-ray techniques have demonstrated inward and outward motion of the chest wall, indicating that this may be an important mechanism of pulmonary injury during vibration.

Bibliography

1. Fowler, R. C. "Damage to Animals Due to Vibration." Supplement to Shock and Vibration Bulletin, No. 22, Office of the Secretary of Defense, pp 16-18, July 1955.
2. Boorstin, J. B., Hayes, J. R., Goldman, D. E. "Injury Mechanism of Internal Organs of Animals Exposed to Sinusoidal Vibration." Aerospace Medicine, Vol. 37, No. 1, pp 22-28, Jan. 1966.
3. Roman, J. A. "Effects of Severe Whole Body Vibration on Mice and Methods of Protection from Vibration Injury." USAF WADC Technical Report 58-107, April 1958.
4. Papé, R. W., Becker, F. F., Drum, D. E., Goldman, D. E. "Some Effects of Vibration on Totally Immersed Cats." J. Appl. Physiol., Vol. 18, No. 6, pp 1193-1200, Nov. 1963.

5. Clemedson, C. J. "Blast Injury." *Physiol. Revs.*, Vol. 36, pp 336-354, July 1956.
6. White, C. S., Richmond, D. R. "Blast Biology." Lovelace Foundation for Medical Education and Research, Albuquerque, N. M. TID-5764, 18 Sept 1959.

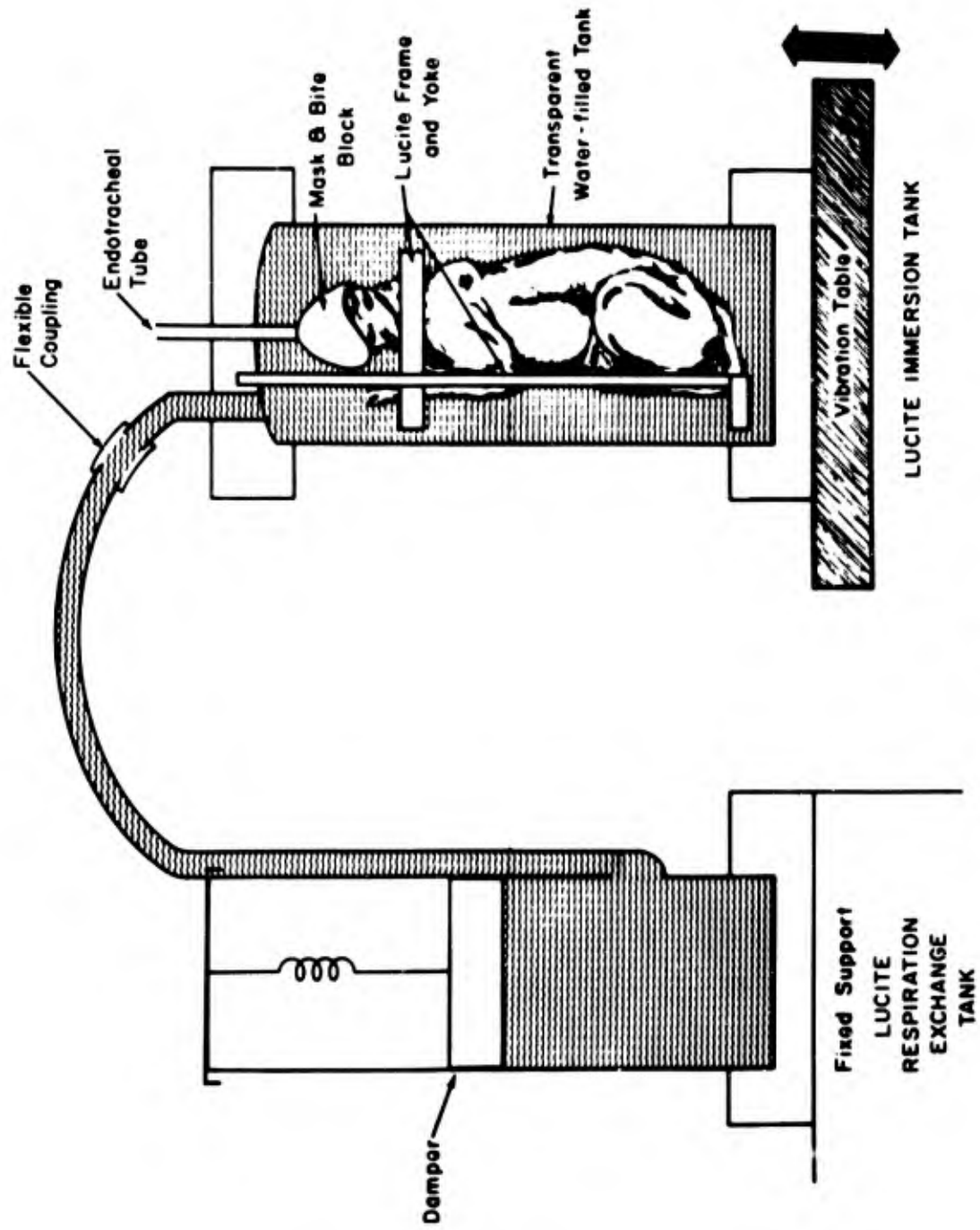

Figure 1 Water Immersion Restraint Scheme

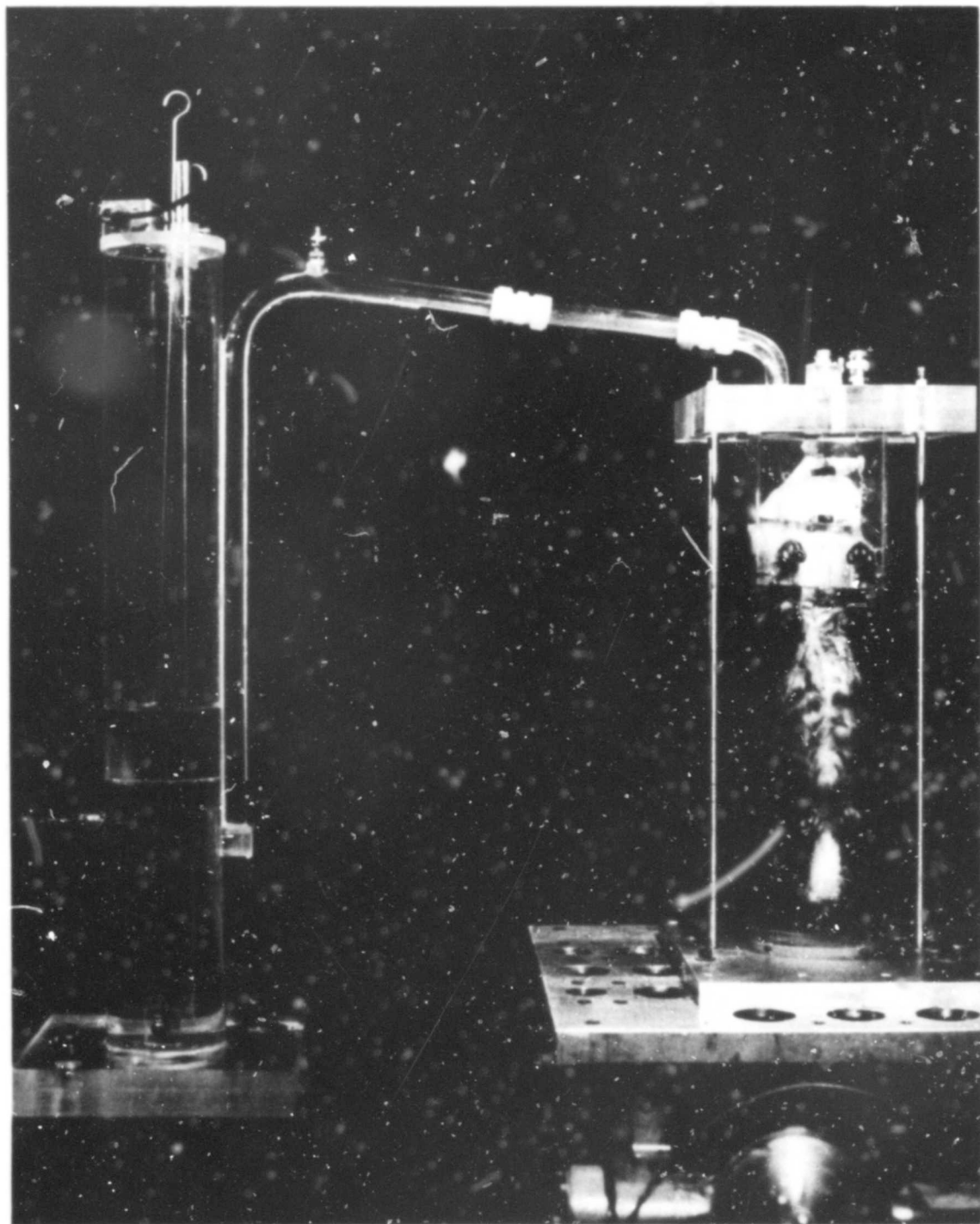

Figure 2 **Photograph of the Experimental Arrangement**

	<u>PEAK ACCELERATION \pm G</u>					
	0	1	2	4	8	15
<u>VIBRATION FREQUENCY - HZ</u>	5					
3.5		3	3			
5		3	2	2		
7		1	2	2	2	
9				2	2	2
12				2	6	17
20				2	4	

Table 1 Number of Animals Subjected to Each Combination of Frequency and Acceleration

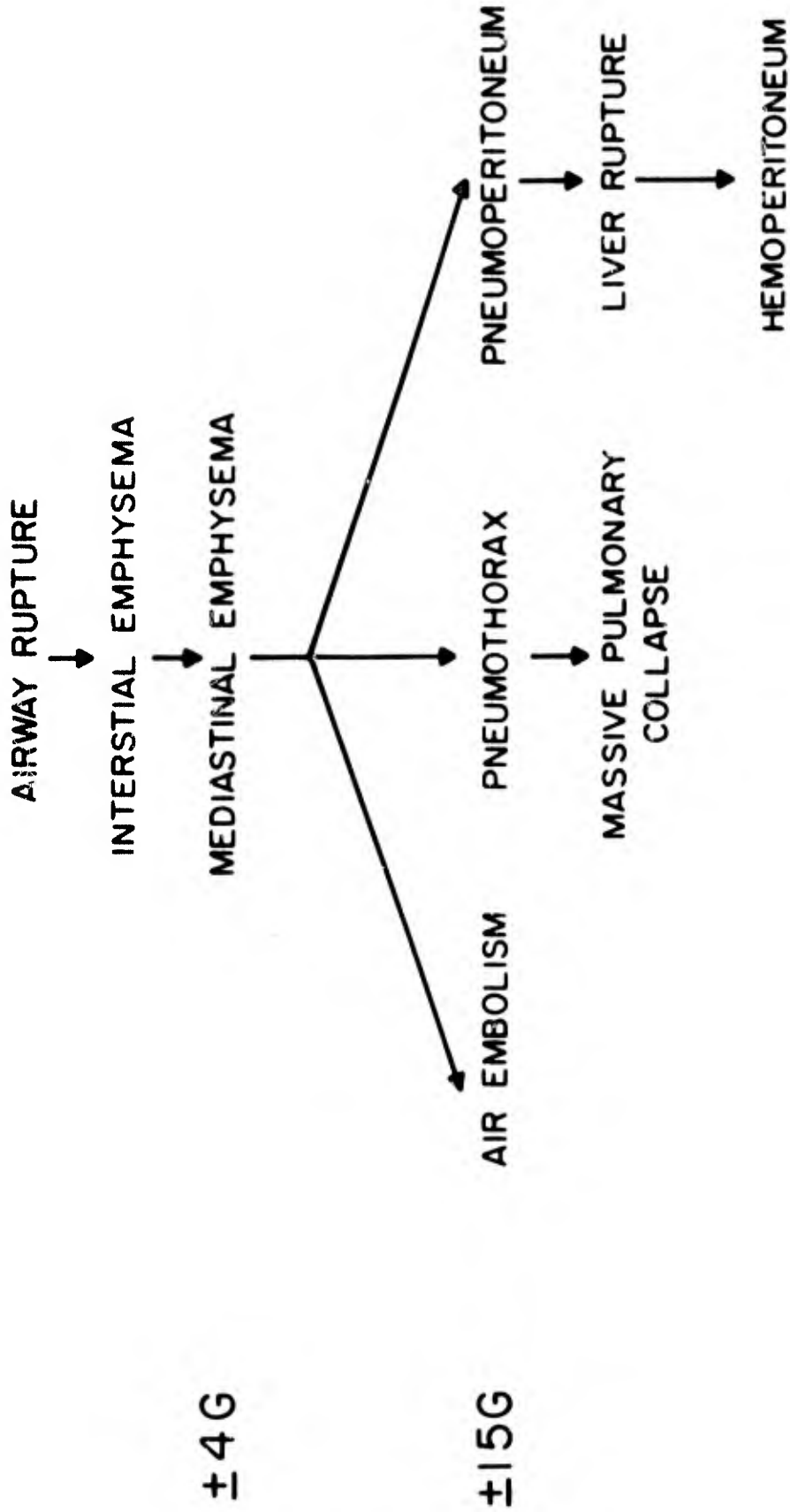

Figure 3 Sequence of Injury Resulting from Vertical Vibration in the Erect Cat

BALLISTOCARDIOGRAPHIC DETERMINATION OF STROKE
VOLUME AND CARDIAC PERFORMANCE

by

H.W.Kirchhoff, Lt Colonel, MC

Institute of Aviation Medicine of the
German Air Force

BLANK PAGE

BALLISTOCARDIOGRAPHIC DETERMINATION OF STROKE VOLUME AND CARDIAC PERFORMANCE

H.W.Kirchhoff, Lt Colonel, MC

The assessment of range and limits of functional capability as well as the conservation and strengthening of health are of special concern to aviation medicine. Its main task is to keep the pilot fit and efficient as long as possible and to protect him from a number of diseases which are commonly called civilised ailments. In the German Air Force special flight-surgeons are assigned to every flying unit or flying training school, whilst the clinical division of our Institute of Aviation Medicine is responsible for selection and survey of all pilots of the Federal Armed Forces at scheduled intervals. The state of health and fitness of this group is therefore observed and traced for years, even decades, and the physical and psychological efficiency of every pilot is evaluated and recorded and serves as a useful basis for studies on long term prognosis. One of our main efforts is the application and development of methods for early recognition of endangered subjects, especially of the diagnostic possibilities for registering and evaluating of risk factors and pre-clinical symptoms in apparently healthy persons. We have in particular developed a series of examination procedures for cardiovascular and pulmonary function, which we believe will enable us to pronounce an early and precise diagnosis. The ECG program of our cardiologistical team for example, includes, besides the registration of all standard leads the functional ECG taken during and after exercise on the treadmill or bicycle-ergometer, the combination of exercise with determined hypoxia for measuring the coronary reserve, the long term ECG applying various testing procedures for determining the nature of arrhythmias. Work load tests under "steady state" and "vita maxima" conditions enable us to determine the efficiency and the functional correlation between cardiovascular and respiratory reactions. The determination of the respiratory quotient allows conclusions concerning reasonable stress and limits of functional capacity. The determination of the specific ventilation serves as an indication of the respiratory regulation and beathing economy under stress conditions. Pulse rate and blood-pressure indicate the degree of regulation of the peripheral circulation, while from the oxygen intake (in milliliters per heart beat), statements can be made concerning the cardiac output, this of course only with certain reservations. The measurement and determination of the parameters of stroke volume and minute volume, both important are still a major issue in modern cardiology. The use of the catheter or the indicator dilution technic necessitate a surgical intervention and the values obtained in can be evaluated only with caution. The sphygmographic circulation analysis, developed in Germany, has only partially succeeded in cardiology, since the determination of the different parameters includes a number of values which can only be measured with difficulty or inaccurately; for instance pressure gradient or length and cross-section of the aorta. After many deliberations, we considered the ballistocardiographic determination of stroke volume and performance of the human heart to be a suitable method. Ballistocardiographic examinations (Fig.1) can be carried out quickly,

painlessly and as often as desired, similar to the registration of the ECG and BCG measurements have indeed a certain similarity.

The peaks of the tracing are designated by letters (Fig. 2), the BCG provides information on the mechanical properties of the heart, whereas the ECG records electrical voltages of stimulation of the heart. In this respect, ECG and BCG complement each other, even though they are based on entirely different principles. Consequently, a subject having a pathological ECG will not necessarily have an unfavourable BCG or vice versa. While our ECG knowledge can hardly be broadened today, we are just at the beginning of our findings resulting from ballistocardiograms. Furthermore, the electrocardiogram is normally evaluated only in a qualitative manner, while with the BCG also a quantitative information can be obtained. Ballistocardiography is therefore of twofold importance.

The basic principle of ballistocardiography is based on the physical law of inertia. The subject lies on an easily moveable table. The force transferred to the body by the systolic ejection of the arterial blood into the aorta is picked up by the table and the minute movement (some tenths of millimeters) is registered by pressure-transducers. The procedure most frequently applied today is the measurement of the acceleration or, if the moving mass is also being considered, the measurement of force or of pressure. In order to apply this method for the calculation of the stroke volume, a special ballistic table was developed by our team. The table permits measurements of the components of forces in the X and Y directions (lateral and longitudinal axes of the body) resulting from the action of the heart.

For physically reliable measurements, the following conditions must be met:

1. Optimal contact between the body of the person to be examined and the ballistic table which picks up impulses and passes them on.
2. Measurement of acceleration in order to calculate the stroke volume and the performance of the heart.

To meet these requirements our ballistocardiographic table having a bed of polyester formed to the dorsal contours of a normally statured man was constructed. The forces are transmitted through a T-plate below the centre of gravity of the upper part of the body into 4 pressure-transducers. These are connected in 2 pairs and transform the longitudinal and lateral components of the body movement into voltage. The signals, amounting to a few millivolts, are recorded by a two-channel recorder.

The calculation of the stroke volume and the work carried out by the heart is based on the following physical laws:

- (i) The Law of Hagen-Poiseuille for the determination of the velocity of a fluid flowing in a tube under laminar conditions.
- (ii) The centrifugal law which enables the calculation of the centrifugal force of a body revolving around a centre point.

By application of the first law the mean velocity of the blood during the ejection can be determined, the aorta asc. being considered as a straight tube with laminary flow. Although the flow in the aorta asc. is known to be turbulent, it can be assumed that the difference in the mean velocity of the fluid fronts in laminar and turbulent flow

is insignificant. The calculation of the ejected volume of blood is based on the second law. The mathematical derivation for calculating the stroke volume, which was presented at the Congress of Ballistocardiography in London by my colleague Dr Burkhart, will be published soon and will not be discussed in detail here. The formula is as follows:

$$\frac{V_s}{V_b} = C \times t_{(i-j)} \times A_{(i-j)} \text{ cm}^3$$

where C is a constant value resulting from the derivation, t and A respectively the time and amplitude between the I and J peaks of the curve, while V_b is the mean velocity of the blood according to Poiseuille's law. The minute volume can easily be calculated by multiplication of the stroke volume obtained with the pulse rate. The calculation of the performance of the heart derives from the fact that a force multiplied by velocity is equal to a performance in mkg/sec. or Watt. The amplitude A_{I-J} representing the force and being calibrated on the ballistocardiographic table, multiplication by flow velocity readily gives the performance of the heart. So far no consideration had been given to the fact that the heart only performs work during the systole.

For this reason, a time factor had to be added which will relate the duration of the systole to a heart cycle

$$L = C \times A \times V_b \left(\frac{t_s}{t_h} \right)^2$$

where C = constant value of the measuring system
 A = amplitude
 V_b = mean velocity of blood
 t_s = duration of systole
 t_h = heart cycle.

The stroke volumes measured by this method under steady state conditions fluctuate between 45-112 ml and are higher than comparative values obtained with the aid of the physical circulation analysis. With 20 subjects comparative examinations between our ballistocardiographic measurement and the indicator method were conducted. A relatively close relation between the individual values was the result. Aware of the fact that the determination of the stroke volume, as presented here, has been derived theoretically, an artificial model of a heart was constructed in our cardiological department which allows experimental predeterminations of the cardiac output in a given time. The curves of the artificial heart are almost identical to those of the human heart, thus enabling us to corroborate our theoretical findings from the experimental side.

In conclusion, may I demonstrate a few examples showing the applicability of the method presented. Physical work leads to an increase of the heart rate, an expansion of the blood pressure amplitude and an increase of the stroke volume. From the relative increase of the separate values in relation to one another indications may be found concerning the regulation and economy of the circulation. The smaller the increase of the heart rate, the greater the efficiency of the circulatory apparatus. The possibility of continuous registration is a special advantage of this method. Measurements of pulse rate and stroke volume under the influence of a β -adrenolytic substance (Kö 592 100 mg) have shown a distinct decrease of the pulse rate which

lasts well over 2 hours, while the stroke volume generally increases. The decrease of the pulse rate is therefore paralleled by an increase on stroke volume, a process which can possibly be appraised as compensation effect.

From the examinations presented here I may draw the conclusion that the known possibilities of the qualitative ballistocardiography in addition to the opportunity of a quantitative analysis shown here will extend our past findings concerning the state of circulation. Especially in the field of aviation medicine attention should be given to the method presented.

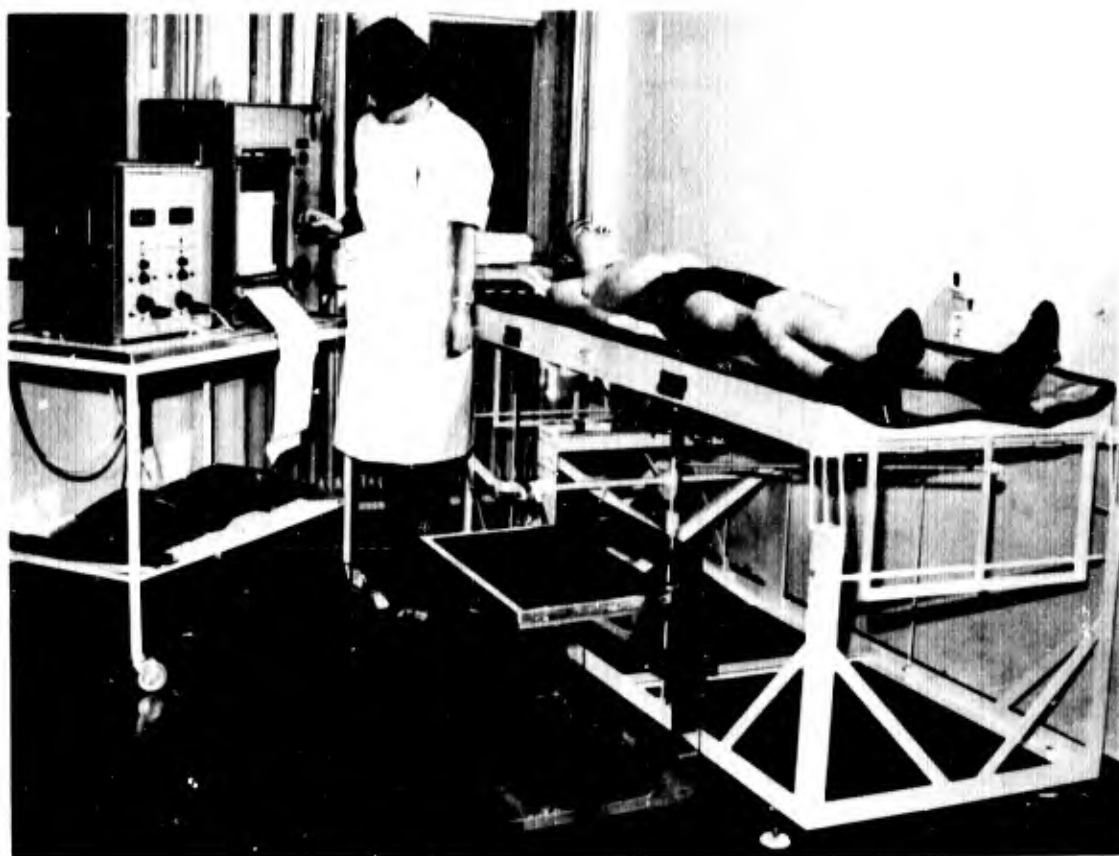

Fig.1 Ballistocardiographic examination

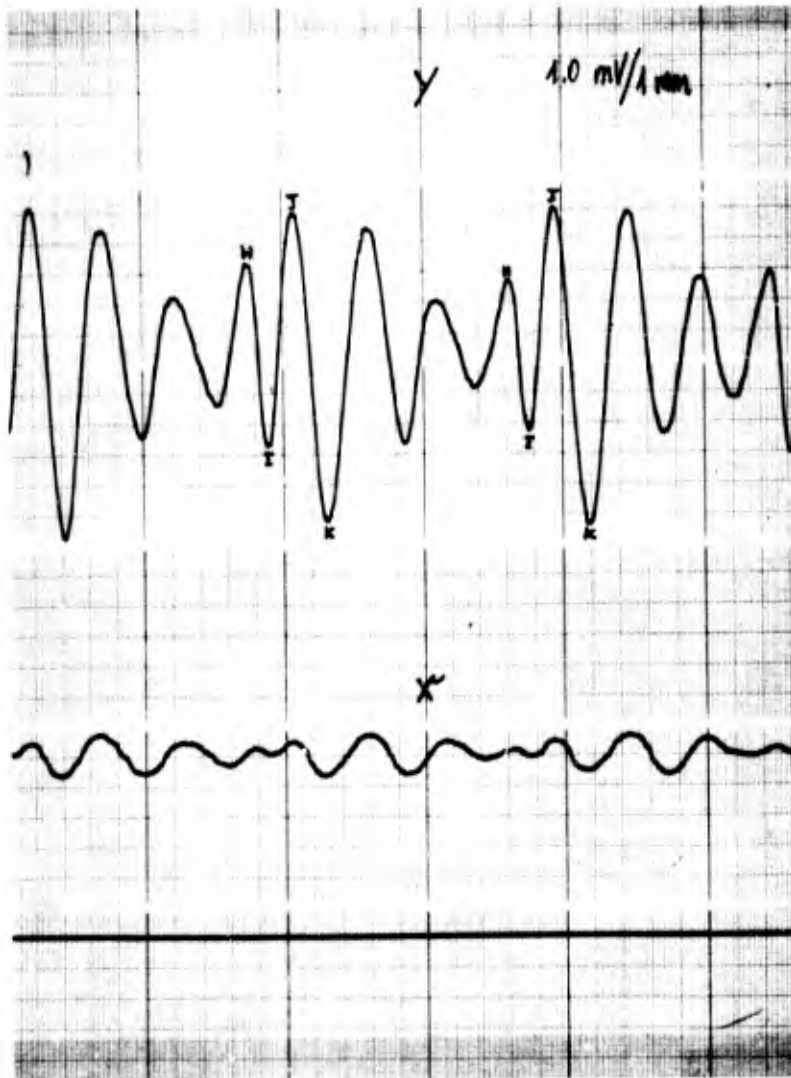

Fig. 2 Ballistocardiograph tracing

PANEL CHAIRMAN'S CONCLUDING REMARKS

I do not feel that there is very much which I can usefully do in closing this Meeting as regards the technical summing up of the proceedings, for we have covered a fairly wide field. Furthermore, the need to sum up in a technical sense is much less at these large meetings of the Panel than at the smaller specialist meetings, at which the whole importance of the meeting is concentrated in the technical summary.

However, before we depart to our various countries, there are certain things to be said. I have found these scientific sessions of great personal interest and much original work has been presented. The speakers have set a high standard. I should like to congratulate them on this and thank them for the efforts which they put into the preparation of their talks. I should like to thank also the chairmen, who have managed the various sessions admirably.

I should like to thank also the large group of people who have made this meeting possible. First of all our hosts, General Ceuppens and the Belgian Air Force, who have looked after our needs of transport and provided much general support otherwise; to General Ceuppens in particular for a magnificent reception held for us in the delightful Chateau Val Duchesse. We must all thank Mr Dietz and the staff of the von Karman Institute for providing a very suitable lecture theatre, and for the demonstrations of the work of the von Karman Institute. We must thank the Belgian national delegates of AGARD; in particular I should like to mention Professor Haus, the senior Belgian national delegate, who not only welcomed us on our arrival but provided a magnificent party on our behalf. Here too I must mention again General Evrard who, as I said before, has been a mainstay of the Aerospace Medical Panel for many years and to whom, more than any other single person, we owe the success of our present meeting. We must thank also Commandant de Hond for his very interesting discourse and demonstration of the battle of Waterloo. I should like to thank also Mr Ross and the staff of AGARD who have worked untiringly for this meeting. I should also like to mention our interpreters and all those others who have given administrative and secretarial support. I was delighted to see the large number of people attending this meeting of the Aerospace Medical Panel. There were rather more than 100 registrations and, in contrast to several other meetings of the Aerospace Medical Panel, the attendance did not seem to get any smaller as the time went on. I thank you all very much for this attendance, and I am sure that it is a sign of the excellence of the speakers.

So much for the 24th Annual Meeting; but there are other matters also. As many of you already know, my term as Chairman of the Aerospace Medical Panel is now ended and, at the Business Meeting earlier in the week, my successor was elected by the Panel members. I should like to take this opportunity to say briefly and most sincerely to you all, how much I have been stimulated by, and enjoyed my time as your chairman. It has been a most interesting and worthwhile task, and I feel that after two years I am beginning to find out what it is all about. I should like to thank all panel members and others who have contributed to our meetings, for the constant support and encouragement which I have been given, and for the general willingness of all who work together in a NATO team. Such regrets as I have at leaving the chairmanship are overcome by knowing that for the next two years the chairmanship will be in the charge of General Lauschner, who has been your deputy chairman for the past two years. I am now going to ask General Lauschner formally to close this 24th Meeting of the Aerospace Medical Panel and in doing so, though I know he really needs no introduction from me, I should like to present him as your new chairman. I wish him all success in this task and I hope that he will have as much pleasure in it as I have had.

H. L. Roxburgh
Air Commodore, RAF
Chairman, Aerospace
Medical Panel

BRIGADIER GENERAL LAUSCHNER'S CLOSING REMARKS

Gentlemen,

Our chairman has conveyed his thanks to everybody concerned. It is my pleasure to thank him on behalf of all of us, not only for the very good meeting he has so carefully prepared and so competently chaired, but for all the work he has done for our Panel during the last two years.

Having been close to him during this time, I can state that he has devoted a great part of his precious time to the Panel activities. He has indeed been an excellent chairman - competent, devoted, stimulating, patient, tolerant and successful. His final decision has often resolved a difficult problem, and his sense of humour cleared a delicate situation. I should like to thank him very much for his fine chairmanship, but I must say that it seems to me rather difficult to be his successor.

It is good to know that he remains not only a Panel member, but also a member of the Technical Programme Committee. I should like to wish him a period of leisure now but, knowing him rather well, I understand that there is only work, and work again, waiting for him when he returns home.

Congratulations, Air Commodore Roxburgh, for your very fine chairmanship, good luck for your future work, and many thanks again.

TECHNICAL EVALUATION
of the
TWENTY FOURTH AEROSPACE MEDICAL PANEL MEETING
by
Wing Commander T. C. D. Whiteside, RAF

The 24th Meeting of the AGARD Aerospace Medical Panel took place at the von Karman Institute for Fluid Dynamics at Rhode-Saint-Genese, near Brussels. The scientific sessions lasted three days, from Wednesday, 25th October 1967 to Friday, 27th October.

"Behavioural problems in Aerospace Medicine" had been selected as the main theme, with particular reference to such aspects as diurnal rhythms, sleep, and alertness, and recent medical problems of space and of air warfare. Accordingly, the thirty one papers, each of which was allocated 15 minutes, were grouped into four experimental sessions dealing with:

1. Human factors in air weapon systems;
2. Review of current space medical problems;
3. New medical and physiological facts in air warfare;
4. Miscellaneous topics.

The general impression was that of a rather outstanding meeting as judged by the scientific quality of the papers, their method of presentation, and the continued interest exhibited by the audience throughout an arduous three days. Numerous short papers, as at this meeting, are certainly more exhausting for the audience, but they do maintain interest more readily by reason of the variety in topics and in presentations. There must be however, as in this meeting, a clearly defined theme to which the communications are related.

In the section on human factors in air weapon systems, the theme centred on the problems of sleep and wakefulness, and how these, and man's performance in general are related to the normal 24 hour pattern of activity. While all work on this subject eventually has a bearing on military operations, that aspect of the question was particularly obvious in the paper on "the periodic variations in indices of human performance", in which it was shown that reaction time, mental

performance and the resistance to some physical stresses were best during the hours the subject was accustomed to being awake. Thus, even after the subject had rested all day, it was found that when the tests were given at night, reaction time was longer, mental performance was poorer, and the resistance to some physical stresses was lower. These effects occurred when the individual had no time to acclimatise, so they clearly have a bearing on the performance of shift workers at the start of the period of night duty and, in particular, they seem to be important to the aviator - either civil or military, who has to fly at night without the benefit of some days of acclimatisation.

The quality of sleep which such a man may have had in his 'resting day' cannot however be disregarded, for in subsequent papers it was shown that visual alertness, for example, is related to a particular type of sleep characterised by the occurrence of rapid eye movements beneath the closed eyelids.

The same test was employed to evaluate a number of drugs which might be of use in ensuring that maximal benefit was derived from sleep - particularly when this had to be taken at unusual times, either because of periods of duty, or because of the time changes caused by moving East or West through a number of time zones, into an environment with which the individual was out of phase.

The biochemistry of sleep, whilst being related to the physiology underlying the choice of sleep-inducing drugs, incidentally highlighted the lethargy and bizarre behaviour of primates, in which the level of the neural transmitter substance (norepinephrine) in the brain was experimentally reduced.

The time required for readjustment of the sleep-waking pattern was discussed in a paper on desynchronisation and resynchronisation of human circadian rhythms. It was shown that the time required depends, amongst other factors, on the direction of the phase shifts and that, in general, adjustment of the individual's circadian rhythm to his new environment seems to last longer after a westward than after an eastward flight.

In the course of the session reviewing current space medical problems, sleep again figured, but on this occasion it concerned the requirements during manned orbital flight. It was concluded that astronauts should if possible maintain the usual pattern of about 16 hours awake and 8 hours asleep or, failing this, 12 hours awake and 6 hours asleep plus an extra 2 hours rest in each 24 hour period. Although, if they followed other rhythms, individuals might reveal no change in performance of psychomotor tasks, the inevitable decrement in

performance caused by an added stress, was least marked in those subjects who had been following a cycle of 16 hours work and 8 hours rest.

The important problem of the hazard of fire in oxygen enriched environments again aroused much discussion regarding various techniques of combating such fires. The main recommendation however is to try to avoid the use of such environments in, for example, a hyperbaric chamber, by administering oxygen through an oronasal mask.

Two further papers aroused special interest. One considered methods of quantifying biological effects of cosmic radiation by means of bacterial cultures, and the other using the Langley sub gravity simulator, examined the ability of subjects to walk under reduced gravity such as would be encountered either on the lunar surface or on a space station in which artificial gravity is produced by rotation.

The communications in the remainder of the meeting drew attention to a variety of topics and problems. Many were specifically directed to the specialised audience, but of more immediate application to the operational users one might mention papers on the development and provision of suitable protective clothing for aircrew in hot humid environments, the development and trial of flash blindness spectacles, a particular type of aircrew selection test, and the effect of a 5 week stay at 2250 metres altitude, on some aspects of pulmonary function.

To summarise, the quality of the majority of papers was good and had a fairly close bearing on the practical situation. The main theme, that of sleep, and its relation to performance in general, is not new as a problem. What is new are the advances which are now being made in this subject and the interpretation of these advances in terms applicable to the 'user'. It is clear that attention to this and to future work on the subject will bring about better employment of men who have to be on duty at times when the remainder of the community is asleep. In particular this is of importance to aircrew who may under these circumstances perform duties satisfactorily as long as all goes well, but who may fail under the extra stress imposed by emergency or unexpected conditions.

LIST OF PARTICIPANTS

W. Albrecht	SAF Bonn	Germany
A. Allard	SABENA	Belgium
B. Anet	SABENA	Belgium
E. R. Archibald	Wright-Patterson AFB	USA
J. Aschoff	Max-Planck Institute	Germany
J. A. Bailey	-	USA
E. Ballinger	Brooks AFB	USA
J. Bande	B. A. F. (C. M. A.)	Belgium
A. J. Benson	R. A. F. (I. A. M.)	UK
J. Bollerud	Andrews AFB	USA
R. A. Bossee	Naval Air System Command	USA
H. Brouns	SABENA	Belgium
P. V. Brown	A/C Section NATO	UK
J. Bynum	Aeromedical Research Unit, Fort Rucker	USA
H. Chardon	B. A. F. (Comd TAF)	Belgium
G. Chatelier	CERMA	France
A. Corin	SABENA	Belgium
T. J. Crowley	Holloman AFB	USA
J. F. Culver	Brooks AFB	USA
D. Denison	R. A. F. (I. A. M.)	UK
Demaertelaere	B. A. F. (9WMSL)	Belgium
E. de Vries	R. Neth. A. F.	Netherlands
E. Evrard	B. A. F. (CMA)	Belgium
D. Farrer	Holloman AFB	USA
Filion	B. A. F. (C. M. A.)	Belgium
R. Gaudio	Wright-Patterson AFB	USA
C. F. Gell	Submarine Research Lab.	USA
E. Giboin	NATO	Belgium
D. H. Glaister	R. A. F. (I. A. M.)	UK
R. Goldman	US Army Research Inst. of Environmental Medicine	USA
W. F. Grether	U. S. A. F.	USA
J. D. Hardy	Yale University	USA
J. L. Hartman	U. S. A. F. (EOAR)	USA
D. E. Hewes	NASA Langley Research Center	USA
P. Janssen	Université Louvain	USA
L. Johnson	U. S. A. F.	USA
W. L. Jones	NASA	USA
R. Jooker	B. A. F. (10WChB)	Belgium
H. Kilchhoff	G. A. F. (I. A. M.)	Germany
K. E. Klein	DVLR	Germany
Knight	Scientific Affairs Div. NATO	UK
T. B. Kolling	R. Neth. A. F.	Netherlands
C. Kratochvil	Holloman AFB	USA
A. Kriebel	Afcnt	Germany

A. M. Landrain	B. A. F. (C. A. M.)	Belgium
E. A. Lauschner	G. A. F. (I. A. M.)	Germany
L. Libber	US Office of Naval Research London	USA
B. Liddy	Canadian Forces (IAM)	Canada
P. Lievens	B. A. F. (C. M. A.)	Belgium
A. Lunn	R. D. A. F.	Denmark
W. Mackie	Royal Navy	UK
R. S. Malone	H. Q. USAF (AFMSP)	USA
L. Mangelschot	B. A. F. (C. Perf)	Belgium
P. Maurice	SABENA	Belgium
L. Meakin	Naval Air Development Center	USA
J. W. Miller	Office of Naval Res.	USA
R. Moens	B. A. F. (EVS)	Belgium
R. Moorhamer	B. A. F. (CMA)	Belgium
J. Murphy	Brooks AFB	USA
D. Nelson	Canadian Forces H. Q.	Canada
O. Nyby	R. No. A. I.	Norway
R. J. Oleynik	US, NADC, Johnsville	USA
A. Pfister	CERMA	France
J. P. Pollard	U. S. Navy	USA
J. Rolfe	R. A. F. (IAM)	UK
F. Ross	Director AGARD	USA
J. P. Rousseaux	1WChTT	Belgium
H. L. Roxburgh	R. A. F. (IAM)	UK
D. G. Sass	Naval Medical Research Institute	USA
A. Scano	IAF (IAM)	Italy
R. Schall	Scientific Affairs Division NATO	Germany
W. Schane	US Army (Fort Rucker)	USA
R. H. Schamburek	US Army (OTSG)	USA
W. Sipple	US NADC Johnsville	USA
E. Smith	R. A. F. (IAM)	UK
A. Swan	Brooks AFB	USA
G. Tolhurst	Office of Naval Res.	USA
P. Vandenbosch	B. A. F.	Belgium
S. S. Varela	Direcção Servico Sande FAP	Portugal
J. Verhelle	B. A. F. (1WChTT)	Belgium
G. Versele	B. A. F. (2ATAF)	Belgium
F. Violette	CERMA	France
A. W. Vogeley	NASA Langley Research Center	USA
B. H. Warren	EOAR Brussels	USA
F. Wattendorf	Vice Chairman AGARD	USA
M. Wolbarsht	Naval Medical Research Institute	USA
M. Whitcomb	National Academy of Sciences	USA
T. C. D. Whiteside	R. A. F. (IAM)	UK
J. Woirin	A/C Section NATO	France
G. Zinnemann	H. Q. USAF (AFMSPA)	USA